

SGP-TR-90

Optimizing Development Strategy
for Liquid Dominated
Geothermal Reservoirs

John **Andrew** Marcou

July 1985

Financial support was provided through the Stanford
Geothermal Program under Department of Energy Contract
No. DE-AT03-80SF11459 **and** by the Department of Petroleum
Engineering, Stanford University



Stanford Geothermal Program
Interdisciplinary Research in
Engineering and Earth Sciences
STANFORD UNIVERSITY
Stanford, California

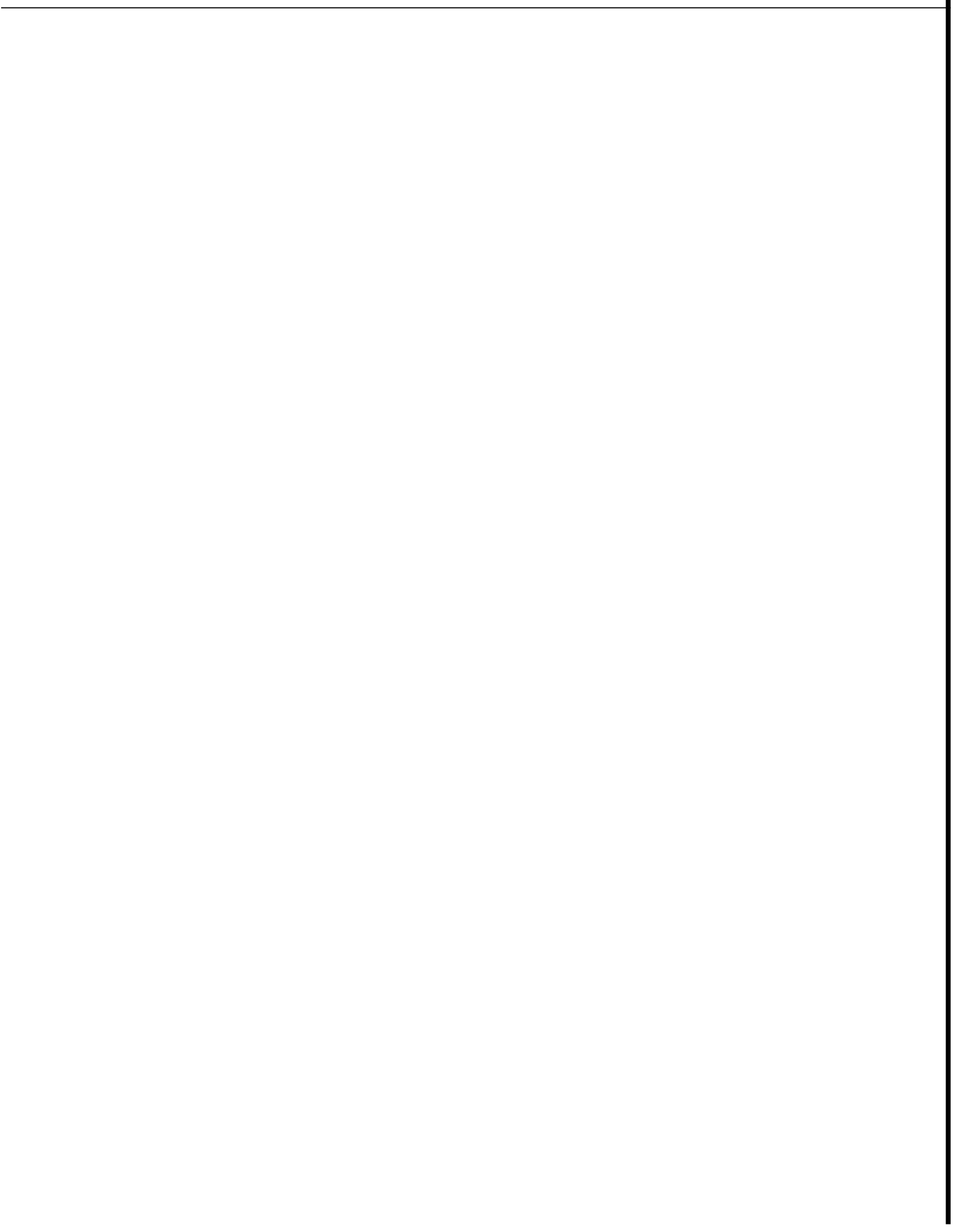

ABSTRACT

Geothermal development is characterized by complex and uncertain decisions concerning the exploitation of an energy source. The constraints imposed upon the exploitation are both technical and economic. Consequently, both of these areas must be treated in order to optimize development strategy. The factors which are most influential on the cost of geothermal development are described, including field deliverability, and well and plant design. A development model which integrates these economic and technical factors of geothermal development is presented. Results indicate that the best choices in plant and well design are strongly influenced by the long term productivity of the reservoir, especially in smaller reservoirs. Finally, there is a discussion about treating uncertainty in geothermal development. Staging geothermal development reduces the risk of oversizing the plant but creates costly delays.

•

TABLE OF CONTENTS

	<u>Page</u>
ABSTRACT	i
TABLE OF CONTENTS	ii
LIST OF TABLES.....	iv
LIST OF FIGURES	v
1. INTRODUCTION.....	1
2. DEVELOPMENT MODEL DESCRIPTION.....	4
2.1 Objective of Development Model.....	4
2.2 Elements of Development Model	5
2.3 Optimizing Development Strategy	6
2.4 Physical Features of Development.....	7
2.5 Development Choices	10
2.6 Physical Features Not Considered.....	12
2.7 Development Block Diagram.....	13
3. FIELD DELIVERABILITY	15
3.1 Reservoir Drawdown Modeling.....	15
3.2 Reservoir Inflow Performance	21
3.3 Well Performance	26
4. MODELING DRAWDOWN OF WAIRAKEI AND AHUACHAPAN	29
4.1 Wairakei History Match and Prediction.....	29
4.2 Ahuachapan History Match and Prediction.....	34
5. DETERMINING FIELD PRODUCTIVITY.....	36
6. POWER PLANT	39

7. DEVELOPMENT COST	43
7.1 Estimating Cost in Geothermal Development	43
7.2 Steamfield Development Cost	45
7.3 Power Plant Development Cost	47
7.4 Calculation of Costs in Development Model.....	48
8. USING THE DEVELOPMENT MODEL.....	51
8.1 Development Model Computer Program	53
9. RESULTS AND DISCUSSION.....	55
9.1 Effect of Reservoir	68
9.2 Effect of Plant Choice	60
9.3 Effect of Conversion Efficiency	62
9.4 Effect of Constant Rate Production	62
9.5 General Applicability of Results	64
10. UNCERTAINTY IN GEOTHERMAL DEVELOPMENT	65
10.1 Characterizing the Uncertainty in Field Deliverability Outcome	66
10.2 Evaluating Uncertain Strategies	68
10.3 Example of Uncertainty in Geothermal Development	69
11. CONCLUSIONS	74
12. RECOMMENDATIONS	76
REFERENCES.....	77
TABLES	81
FIGURES	91
APPENDIX A: Program Hursgraphrad, Plus Sample Input and Output	128
APPENDIX B: Program Hursradfit, Plus Sample Input and Output	134
APPENDIX C: Programs NPV.Central and NPV.Wellhead, Input and Output	139
APPENDIX D: Cost of Power Calculation for the Decision Tree Example	155

LIST OF TABLES

	<u>Page</u>
1) Major Economic Factors Affecting Geothermal Development (Tester')	81
2) Values from Calculation of Well Flowing Pressure.....	82
3) Wairakei Reservoir Parameters	82
4) Wairakei Production and Drawdown	83
5) Hurst Constants from Two Wairakei History Matches	84
6) Wairakei History Match Results	84
7) Ahuachapan Reservoir Parameters.....	85
8) Ahuachapan Production Data	86
9) Ahuachapan History Match and Results	87
10) Steamfield Costs Obtained from Field Studies	87
11) Power Plant Costs Obtained from Field Studies	88
12) World Data on MWe per Well.....	89
13) World Data on MWe per Well Sorted by MWe per Well.....	90

LIST OF FIGURES

	<u>Page</u>
1) Physical Features of Liquid Dominated Development.....	91
2) Pressure/Enthalpy Path of Geothermal Fluid (Reynolds⁴⁸).....	92
3) Silica Deposition Constraint (Gudmundsson and Bott⁵).....	93
4) Tauhara Power Optimization Curves (Southan. et. al. ⁴).....	94
6) The Geysers – Steam Rate vs. Wellhead Pressure (Ramey⁵)	95
6) Geothermal Development Block Diagram.....	96
7) Reservoir Pressure Drawdown vs. Cumulative Produced Mass in Three Liquid Dominated Fields.....	97
8) Svartsengi Drawdown vs. Produced Mass. Field Data and Match with Hurst Simplified Model (Gudmundsson and Olsen¹⁵)	98
9) Hurst Simplified Reservoir and Aquifer Two-Lump Model	99
10) General Reservoir Inflow Performance Curve.....	100
11) Vogel²⁴ Solution Gas IPR.....	101
12) Reservoir Inflow Performance Curve with Details of Construction Above and Below the Saturation Pressure.....	102
13) Reservoir Inflow Performance Curve Compared to Roosevelt Data.....	103
14) Effect of Decreasing Reservoir Pressure on Reservoir Inflow Performance.....	104
15) Mass Rate vs. Well Size and Productivity Index (Butz²⁸)	105
16) Well Performance Curves Derived from Roosevelt Data	106
17) Wairakei Production Data (Love and Bolton¹¹)	107
18) Wairakei – Predicted and Actual Drawdown vs. Cumulative Produced Mass.....	108
19) Wairakei – History Match and Forecast of Drawdown vs. Cumulative Produced Mass	109
20) Ahuachapan – Predicted and Actual Drawdown vs. Cumulative Produced Mass.....	110

21) Ahuachapan - History Match and Forecast of Drawdown vs. Cumulative Produced Mass	111
22) Reservoir Inflow Performance and Well Performance Based on Roosevelt Data.....	112
23) Reservoir Inflow Performance and Well Performance Based on Roosevelt Data for Different Reservoir Pressures	113
24) Mass Rate vs. Reservoir Pressure Derived from Reservoir Inflow Performance and Well Performance Based on Roosevelt Data for Different Reservoir Pressures	114
25) Reservoir Inflow Performance, Based on Svartsengi P.I., and Well Performance, Based on Roosevelt Data.....	115
26) Flowchart for Development Model Program.....	116
27) General Result for Net Present Value of Development Cost vs. Generation Level	117
28) Total Number of Wells Required vs. Generation Level	118
29) Effect of Different Reservoir Drawdown Behavior on Development Cost	119
30) First Year Cost Fraction of Development Cost vs. Generation Level for Two Reservoir Scenarios	120
31) Effect of Plant Choice on Development Cost with Ahuachapan Match Parameters.....	121
32) Effect of Plant Choice on Development Cost with Wairakei Match Parameters	122
33) Effect of Conversion Efficiency Difference on Development Cost with Condenser and Backpressure Wellhead Units.....	123
34) Effect of Constant Rate Production on Development Cost with Ahuachapan Match Parameters	124
35) Effect of Constant Rate Production on Development Cost with Wairakei Match Parameters	125
36) Histogram of World Data on MWe per Well	126
37) Decision Tree for Example of Risk Analysis In Geothermal Development	127

1. INTRODUCTION

Geothermal reservoir development is characterized by complex and uncertain decisions concerning the exploitation of an energy source. The constraints imposed upon the exploitation are both technical and economic. Consequently, both of these areas must be treated in order to optimize development strategy. The factors which are likely to play a significant role in geothermal development are described. A development model which integrates these economic and technical factors of geothermal development is presented. This model is used to draw some conclusions about the dominant features of development. Finally, there is a discussion about treatment of uncertainty in geothermal development.

The topic covers all aspects of development, therefore, an effort must be made to treat it in a manageable fashion. This starts with a careful definition of the problem. Secondly, the components of the development model must be versatile yet simple. Versatile enough to handle variations in any one component, such as the variations in plant design, yet simple enough to keep the interaction of the different components straightforward. Finally, it helps to test the components of the development model with field data whenever possible.

As geothermal reservoirs are depleted the average reservoir pressure changes. Generally, the effect of mass withdrawal is to cause the reservoir pressure to drop. (However, the compressibility of the reservoir rock and fluid, as well as the influence of recharge from the surrounding regions, serves to maintain the reservoir pressure and can cause it to *increase* when the rate of mass withdrawal decreases.) The decrease in reservoir pressure causes a decrease in the field deliverability because it is the difference between the reservoir pressure and the surface pressure that provides the force to drive fluids to the surface.

Over time, the mass rate of production will decrease until a physical limit to production is reached, and the well no longer flows, or until an economic limit is

reached, and the well must be abandoned. For a particular reservoir, the choices of well design and generation facilities can have a pronounced effect upon the deliverability of the reservoir over time. However, these are not clear cut choices since they often involve a trade-off between the benefits of improved efficiency in one part of the system at the expense of greater cost or lower efficiency in another part. A development model allows the benefits and cost trade-off to be examined for a variety of development scenarios, leading to the best choice.

In this study, the development model is specifically used to examine the economic impact of declining field deliverability, on the choice of development strategy in liquid-dominated reservoirs. The decision process described here occurs when the exploration phase has been completed and the development of the field is to be undertaken. This implies that some description of the resource and reservoir characteristics is available, although these would be uncertain.

Previous literature has discussed the optimum strategy for development. In "Proving and Development of Geothermal Fields Risk, Strategy and Economics" Barr, Grant and McLachlan⁷ stated that the major risks are uncertainty in the size of the field and inability to assess a field's capacity until operations had proceeded for some time. They concluded that the most appropriate strategy is to stage development and gain information while generating some revenue. The recommendation was made that the initial targeted level of generation be one-third of the original exploration assessment. In the paper "Optimal Energy Extraction from a Hot Water Geothermal Reservoir" , Golabi, Scherer, Tsang and Mozumder⁸ used maximization of present value of the net revenues from sales of energy for space heating as an objective for development. Well life had a great effect upon profits, optimal reservoir life, and optimal pumping rate. In "Optimising Field Proving and Development", Grant and Barr⁹ discussed the basic trade-off between additional proving effort and consequent expense and delay. They assumed a triangular

distribution of possible reservoir outcomes and concluded that the optimum initial development size was one which left a 10% to 20% chance that the station would be oversized because some risk of oversizing must be assumed in order to balance the risk of undersizing and delaying revenue. All of these papers addressed the influence of field production capabilities on the best strategy for development. In this report, an analytical treatment of field deliverability is tied to an economic criterion of performance in a development model.

2. DEVELOPMENT MODEL DESCRIPTION

2.1 Objective of Development Model

It is the objective of the development model to formulate and combine the dominant features of geothermal developments into a single, consolidated model. This requires mathematical description of the physical and economic factors of development. Ultimately, a complete development model can be used to explore the desirability of development, given different choices in development strategy and different outcomes in some of the uncontrollable features of the development.

Thus, to start with, the physical process of extracting the geothermal resource from the ground and transforming it into a product, be it heating fluid or electricity, must be described. Equally important are the economic issues of the development. One must describe the incentive for development (the benefits) as well as the costs incurred in development of the geothermal resource.

The physical process and the economic issues must both be considered in order to determine the best development strategy. For example, from the economic perspective, one may select the most inexpensive form of power plant yet find that this imposes unreasonable demands upon the production from the reservoir. Similarly, designing wells that maximize the production from the reservoir may not be desirable in light of drilling costs.

In the Handbook of Geothermal Energy, Tester' describes the kind of physical and economic features which dominate development of geothermal resources. These features are given in Table 1.

In this work, most of the emphasis is on the reservoir and plant engineering factors and the financial factors. In particular mass flow rate, pressure drawdown and conversion efficiency are the engineering factors considered. Drilling and plant capital costs, and discount rate, are the financial factors which are considered. A

“typical” liquid-dominated resource is assumed, as will be discussed later. The last three financial related factors debt interest rate, selling price, and tax and royalties, were considered too site-specific to be treated in this work,

2.2 Elements of Development Model

The development model can be divided into three categories which encompass the physical and economic features. These are the development objective, choices, and constraints.

The objective is the primary feature of geothermal development. Typically, this would be an economic objective such as profit maximization or cost minimization. The objective provides the criterion for selecting the best strategy (choices) of development. In addition, when an objective is picked, then the impact of the choices on the objective must be defined. If a development choice has no impact on the objective than it will have no effect upon the optimum development strategy. The optimum strategy strongly depends upon the objective.

Development choices incorporate the features of development which can be controlled and selected by the developers. In essence, they represent the strategy of the developers in exploiting the resource. Examples of choices for a geothermal development would be well design and spacing, and power plant design.

Constraints impose limitations upon the choices; developers must work within them in order to effectively develop the resource. The most important constraints are the ones imposed by the resource and market. The resource constraints would include items such as temperature, chemical impurities in the geothermal fluid and field deliverability. The market for electricity imposes price and demand constraints. Another important form of constraint is restrictions on disposal of geothermal wastes. Economic constraints, such as demand levels or budget limits, also exist.

Note that one developer’s choice is another developer’s constraint. For

example, in some areas there may not be a choice in well design due to limited resources. In this case the choice of well design becomes a constraint in well design. The only choice left is whether the well will be drilled or not.

2.3 Optimizing Development Strategy

Once the choices, constraints and objective of the development model are described the problem of optimizing development strategy can be approached in an analytical fashion. The development choices represent variables. For each different selection of variables - that is, for each different strategy - there is a corresponding value of the objective. However, constraints such as well productivity or demand limit the selection of the variables. The variable selection which produces the best value of the objective, subject to the constraints, is the optimum strategy.

Originally, it was intended to model the selection of variables, constraints and objective in geothermal development as a linear program. The reason for this was the powerful solution techniques that can be used on a linear program. An optimal solution, that is the best of *all* possible variable selections subject to the constraints, can always be found for a linear program if it can be properly formulated. In addition, sensitivity analysis can be readily performed and the importance of different constraints can be identified.

After working with the model it became apparent that the linear programming approach would not suffice because the problem was inherently non-linear. Although at any single point in time the problem could be expressed in a linear fashion, the linking of the problem in time made it non-linear. This non-linearity arises because the productivity of the wells at any point in time depends upon the production history to that point. Consequently, the choices (or variable selection in previous times) has a strong influence on the constraints at a later time. However, the effect of well productivity was one of the things to be examined in the study, so the linear programming technique had to be abandoned.

Once the problem is classified as non-linear several solution techniques can be employed in an optimization. Unfortunately, there is no solution technique guaranteed to find the optimum. Solutions may be found which are "locally" optimum but may not represent the best choice out of all the possibilities. Most methods rely on some form of gradient calculation to find directions of improvement in the solution; in a problem where some variables may assume only discrete values this approach may not work. This problem has such discrete variables or choices which represent things like the selection of well diameters.

Another non-linear approach is to search the range of possible solutions to find those which appear to be the best. To do this a routine must be written which will take the various selections of the variables and constraints and use them to calculate a value for an objective function. Changing the variable selection and the constraints will identify those which tend to heavily influence the solution and those which do not. By automating the calculation, of the objective, it is possible to investigate many of the various combinations in development variables and constraints. In this study, the non-linear interaction between reservoir and well productivity, power plant efficiency and economic constraints is examined by these means. A best solution found in this manner can strongly suggest an optimum but not be proven to be the best.

2.4 Physical Features of Development

Both physical and economic features are incorporated in the development model. Figure 1 is a picture of the major physical features of liquid-dominated geothermal development. For simplicity, the development is portrayed with a single flash power plant but, as is discussed later, other forms of power generation can be treated if desired.

The block at the bottom of Figure 1 represents the reservoir. P_{res} is the average reservoir pressure. Well flowing pressure, P_{wf} , is the pressure in the well,

opposite the feed zone. The difference between these two, ΔP_{res} , drives the geothermal fluid through the reservoir and into the well.

The fluid travels up the well to the separator. P_{sep} is the separator pressure. The difference between the well flowing pressure and the separator pressure, ΔP_{well} , drives the geothermal fluid up the well and into the separator. In this study the separator pressure is assumed to be the same as the wellhead pressure. No pressure or temperature losses are considered in the surface transmission lines. For a given fluid enthalpy and separator pressure the steam quality is specified. The properties of pure water are used throughout this work. Multiplying the total fluid rate into the separator by the quality yields the steam rate to the turbines.

The power plant converts a flow of saturated steam (usually measured in tonne/hr, kg/s or lb/hr) into electrical power (measured in MWe). The power plant can be characterized by the conversion efficiency with which it converts the thermal energy carried by the saturated steam into electrical energy. If the temperature of the saturated steam is specified this efficiency can be expressed as a mass rate of steam per unit electric generation, or, tonne of steam/hr-MWe. A condenser is shown in the figure. The presence of the condenser reduces the exhaust pressure of the turbine and greatly increases the conversion efficiency of the plant. However, backpressure turbines can be used, which do not have condensers and exhaust to atmospheric conditions. Re-injection of liquid water from the separator and exhaust of the turbine is depicted in the schematic, yet, it only is treated as a cost of development in the model.

Another way of looking at the physical process is to follow the path of the geothermal fluid on a pressure and enthalpy plot as it travels from the reservoir to the surface and through the turbine. Figure 2 is a pressure and enthalpy plot for pure water (Reynolds).⁴³ Say that the reservoir pressure is 10 MPa with a temperature of 250 °C and enthalpy of 1100 kJ/kg (point A). This would represent

the compressed liquid state of a liquid-dominated reservoir.

If a well is opened and allowed to flow then the fluid moves from the reservoir towards the production well. Assuming that the pressure never drops below the flashing pressure the path will be down along the constant enthalpy line. When it reaches the well (point B) the pressure is the well flowing pressure. In this case the well flowing pressure is depicted as being above the flashing pressure but it could just as easily be below the flashing pressure. If the pressure drops below the flashing pressure in the reservoir then boiling will occur and steam will form. As a result, the fluid enthalpy will tend to increase while the total mass rate of production will tend to decrease due to the increasing presence of steam. More will be said about this later in the section on reservoir performance. For now, consider the pressure to be higher than the flashing pressure in the reservoir.

The fluid travels up the wellbore and into the separator. The pressure drops from well-flowing pressure until the separator pressure is reached. Assume constant enthalpy flow in the well. Then, the path the fluid takes is the one depicted between point B and point C. At point C the steam fraction and liquid fraction are separated and the path follows the steam fraction. The quality of the mixture is specified at point C and can be read from the iso-quality line which passes through point C. Following the steam fraction to the saturated steam line indicates the inlet conditions into the turbine (point D). This ignores the pressure drop between the separator and the turbine inlet. The effect of the assumption is small, however, since for a drop of about 1 bar there is little difference in the enthalpy of the steam.

As the fluid moves through the turbine it is throttled with a series of nozzles and blades and exhausted at some pressure (points E or F). Point E corresponds to exhaust conditions of about one atmosphere (0.1 MPa) as might be found for a back-pressure turbine venting to the atmosphere. Point F corresponds to a condenser and turbine arrangement where the exhaust pressure is sub-atmospheric,

in this case 0.01 MPa. Ideally, the path the fluid takes through the turbine is isentropic, as is shown for points E and F. If the process were ideally efficient, as shown, then the conversion efficiency would be about 5.3 tonne/hr-MWe for the given conditions. According to one manufacturer's data, actual conversion efficiency for the stated conditions is about 7.8 tonne/hr-MWe (Fuji Electric Co.).² The isentropic case represents the exergy, or available work, of the fluid (Kestin²⁹, DiPippo and Marcille³⁰). Irreversible processes give rise to entropy production and, thus, the actual work derived from the process is less than available work. In the above example, the turbine-generator system is about 68% efficiency in tapping the available work and converting it to the actual work.

At this juncture, it is important to mention a constraint in utilizing geothermal fluid. The silica deposition constraint must be considered in order to prevent scaling in the plant, injection transmission lines and wells, and deposition in the fractures at the entry zones of the injection wells. Figure 3 is taken from Gudmundsson and Bott.³ It shows the silica deposition limit for a 250° C reservoir, as is assumed in this study. The figure indicates that, for the flashing case, the limit of deposition is reached at 140° C. Since, in this study, flashing is assumed to take place at about 150° C the silica constraint is not reached.

2.5 Development Choices

Several development choices are apparent from the description of the physical processes. The selection of separator pressure (point C on Figure 2) has several effects. One is that the quality in the separator is determined. It is advantageous to have as high a quality as possible since, the larger the fraction of the total production that gets converted into steam, the smaller the total production is required from the field. Higher quality implies lower separator pressures. Another impact of separator pressure is that it sets the inlet pressure to the turbine. The higher the inlet pressure into the turbine, relative to the turbine exhaust pressure,

the larger the energy content (available work) will be for the geothermal fluid. It is also important to have the turbine inlet pressure close to the optimum turbine efficiency pressure to improve the conversion of thermal energy to shaft work and hence electrical generation. Perhaps the most important feature of selecting the separator pressure is that it determines the total pressure drop between the surface and the reservoir (points C and A respectively). This pressure drop in the reservoir and well determines the deliverability of the reservoir. In terms of choosing the optimum separator pressure, there are several considerations, some of which suggest higher separator pressures and some of which suggest lower separator pressures.

Figures 4 and 5 illustrate this point further. Figure 4 shows the isentropic power per unit mass vs. the separator pressure for the Tauhara Field in New Zealand.⁴ Depending upon the exhaust pressure, there is an optimum separation pressure which yields the greatest isentropic power per unit mass flow rate of geothermal fluid. However, the unit mass flow rate itself depends on the wellhead pressure. Figure 5 shows the decline in mass rate with increasing wellhead pressure from a steam well at The Geysers.⁵ If the separator pressure is assumed equal to the wellhead pressure, or at least as creating a lower limit to wellhead pressure, it is clear that the selection of surface operating pressures has a significant influence on several major features of development. What is just as important, but not shown in either of these figures, is the economic impact of changing the operating pressures. For instance, selection of the best operating pressure from the point of view of power optimization may not be the best in light of mass rate. Despite the loss of optimum power extraction from the fluid, it could be better to operate at a different pressure which will increase the well productivity enough to avoid drilling another well, for example.

Another important choice is the well design. The pressure drop in Figure 2 between points A and C is the pressure available to drive the reservoir fluid to the surface. Some of the drop occurs in the reservoir (A to B) and the remainder occurs

in the well (B to C). The more of this drop that occurs in the reservoir, the greater the amount of fluid driven from the reservoir into the well and, hence, to the surface. However, there must be enough of a pressure drop in the well to push the fluid to the surface. As will be discussed later, the well design has an important impact on the production from the well in some cases, while in others, the reservoir characteristics may overshadow those of the well.

Finally, the exhaust pressure is seen to be important. In this work the exhaust conditions for the turbine are the key factor in determining conversion efficiency, since only the single flash plant is considered. This would represent the choice between a condensing turbine or a back-pressure turbine. Generally, in a **low** temperature process like geothermal generation, any advantage in the efficiency of the process is economic. This would favor the extra cost of the condenser. However, important exceptions to this can occur when low levels of generation or favorable atmospheric conditions exist.

2.6 Physical Features Not Considered

Geothermal brine is treated as pure water in this work which is obviously a simplification. As mentioned before, silica is one form of dissolved solid which must be considered before planning the development. While not treated here, there are other forms of chemical impurities which at least bear mentioning; these impurities are the dissolved solids and gases in the geothermal fluid.

According to Butz⁶ the dissolved solids change the density, enthalpy content and phase behavior of the geothermal liquid. The gases can initiate two-phase flow at pressures greater than the saturation pressure of pure water. Gas content adversely affects the condenser performance, too. Calcite deposition is a noteworthy problem in many geothermal fields. The treatment of these issues is beyond the scope of this paper. However, there is some implicit treatment. For example, maintenance costs drawn from some studies used in the report include the

well **workover** required by calcite deposition.

2.7 Development **Block** Diagram

The block diagram of Figure 6 is an extension of Figure 1. The biggest change is the inclusion of the development cost. The blocks labeled reservoir, well, surface transmission and separation, and power plant encompass the physical options and constraints mentioned above. In order to evaluate the trade-off between the different choices, an objective must be introduced. This is accomplished with economic considerations like development cost minimization, subject to the constraint of meeting market demand. Each of the other blocks - the physical processes - influences the economic performance of the development by way of the development cost. The block diagram also serves as an introduction to the following sections which detail the workings of each of the blocks.

The development model in this work is expressly constructed to explore the effect of field deliverability upon the cost of geothermal development. This aspect of development was chosen because it tends to dominate the economics of the project and can therefore be discussed generally with regards to liquid-dominated reservoir development. That is to say, it is an important consideration in all liquid-dominated developments. However, in general, this approach can be used to explore any relevant issue of development.

In the following sections the details of the methods used to model the different elements of the block diagram are presented. However, it is important to stress that in every case these are not the only ways of modeling the elements a block. For instance, one form of water-influx reservoir model is used in this study but numerous other forms of water influx model exist. Any of these could be used. Similarly, while minimization of development cost is used as an economic criterion, others such as revenue maximization could be employed. Even if other methods are used to model the different blocks, the results presented here indicate that these elements must

be taken into consideration in some form in order to properly plan the development of the field.

In the following sections the blocks describing the reservoir, the well and separation are linked together to determine the field deliverability. Then development costs are discussed. A discussion on running the model and a block diagram of the development model program is given. Finally, the results from the runs of the development model are presented and discussed.

3. FIELD DELIVERABILITY

There are three components required to model field deliverability. The first is reservoir pressure drawdown as a function of production history. This describes the decrease in reservoir pressure as fluid is produced from it. The reservoir pressure is also influenced by expansion of fluids in the reservoir as well as recharge from surrounding aquifers. The second is reservoir inflow performance. This describes the ability of geothermal fluid to flow through the reservoir, given a pressure drop between the reservoir and the well flowing pressure opposite the feedzone. The third is casing performance. This describes the ability of the casing to permit flow of the geothermal fluid to the surface, given a pressure drop between the well flowing pressure opposite the feedzone and the surface pressure. When these three are linked together, the deliverability can be determined.

3.1 Reservoir Drawdown Modeling

A reservoir model should predict the drawdown in the reservoir pressure as a function of time and rate of production. Many models are available, as discussed by **Olsen**.¹⁰ Before describing the model used here, it is instructive to examine Figure 7, which is a plot of reservoir drawdown versus cumulative mass withdrawal for three liquid-dominated reservoirs. Reservoir drawdown is the difference between the initial reservoir pressure, prior to production, and the reservoir pressure at some later time after production has commenced. The cumulative mass scale is logarithmic, which tends to compress the data; this was necessary to put the Ahuachapan and Svartsengi on the same plot with Wairakei. The Svartsengi production data is from **Olsen**.¹⁰ The Wairakei production data is from Love and **Bolton**¹¹ and Stacey and **Thain**.¹² The Ahuachapan production data is from **Quintanilla**¹⁴ and **Vides**.¹³

As Figure 7 shows, there is some similarity in the drawdown behavior of the three reservoirs. Ahuachapan and Svartsengi are much smaller than Wairakei. Consequently, these reservoirs show appreciable drawdown at much lower levels of

cumulative mass production. It is also important to realize that the rate of withdrawal plays an important role in drawdown. The greater the rate of mass withdrawal, the greater the drawdown. Over the life of the field, the production rate has varied for all three reservoirs. In general, however, the rate of production from Wairakei has been about 1500 kg/sec through 1982, the rate of production from Ahuachapan has been about 600 kg/sec through 1983 and the rate of production from Svartsengi has been about 150 kg/sec on average, and is currently about 300 kg/s.

The three fields seem to be reaching nearly the same level of drawdown as cumulative produced mass increases. This steady-state drawdown appears to be about 3 MPa although the drawdown of the two smaller fields has not leveled off as much as Wairakei. This figure indicates that geothermal liquid-dominated reservoir drawdown has a characteristic which can be effectively modeled. The uniform behavior of these three fields supports this notion. In addition, it demonstrates that the particular drawdown behavior of a liquid-dominated field is strongly related to its size.

The topic of water influx modeling of geothermal reservoirs was discussed by Olsen¹⁰ and Gudmundsson and Olsen.¹⁵ Olsen¹⁰ reviewed many techniques for modeling the drawdown from liquid-dominated reservoirs. The best results were achieved with the Hurst Simplified procedure (Hurst^{**}). Gudmundsson and Olsen¹⁵ compared the Hurst water-influx model results to the Svartsengi field data as is shown in Figure 8. The agreement between field and model-predicted performance is close. The model responds well to extreme variations of production rate which tend to coincide with the fluctuations in the curve. The Hurst model, described in greater detail below, falls into a class of reservoir modeling known as predictive material balance. It provides a method of predicting the drawdown in reservoir pressure with production and it can also be used for history matching. As has been mentioned before, this is certainly not the only method for describing the drawdown in

geothermal reservoirs. Olsen¹⁰ described the use of many models on geothermal reservoirs. While estimating reservoir drawdown is critical to development strategy, any model can be used.

The Hurst model has a different form depending upon whether the geometry of the reservoir and supporting aquifer is assumed to most closely resemble a linear or a radial geometry. The linear form was discussed by Olsen¹⁰. For this work, a radial form was employed.

In the Hurst model the reservoir is a radially symmetric, permeable layer with homogeneous properties (see Figure 9). The supporting aquifer is also a radially symmetric layer, infinite in extent, with some of the same properties as the reservoir. The aquifer provides recharge to the reservoir only along the radial edge of the reservoir cylinder. There is no flow into the reservoir through the bottom surface or the top.

There is one important difference in the Hurst model between the aquifer and the reservoir properties; the compressibilities can be different. In the oil reservoir case this would be due to the fact that the fluid flowing across the reservoir/aquifer boundary (water) has a substantially different compressibility than that of the fluid which is being produced (oil). In the liquid-dominated geothermal case there is a compressibility difference, too. The high temperature and boiling in the reservoir can give rise to large compressibilities compared to a liquid-only aquifer surrounding the reservoir. Thus, when using this model for history matching or predicting the reservoir compressibility will be a time-averaged value. This value may be close to that of a pure liquid reservoir, a steam only reservoir, a boiling dominated reservoir or something in-between.

In the Hurst simplified model the reservoir is treated as one "lump" with homogeneous properties. Then, over some period of time, a constant rate of mass withdrawal is applied to the reservoir. A material balance equation is then applied to

the control volume and the resulting pressure drop in the “lump” is determined. There is flow from the surrounding aquifer into the reservoir resulting from the pressure drop in the interior “lump.” In this way the model predicts the water influx into the reservoir created by the removal of mass from the reservoir lump. Using the principle of superposition, a changing rate of production can be approximated as a series of step changes in constant production. The pressure response in the reservoir is then found as the sum of the reservoir response to these rate changes. Thus, the model is capable of predicting drawdown due to unsteady-state flow from the reservoir.

Equation 3.1.1 is the radial expression of the Hurst simplified model.

$$\Delta p = \frac{\mu_a}{2\pi kh\rho_a} \sum_{j=0}^n \left[\Delta w_j \sigma N\left(\sigma, t_D - t_{Dj}\right) \right] \quad (3.1.1)$$

where: Δp = decrease in reservoir pressure since start of production (MPa)

μ = viscosity (Pa-s)

k = permeability (m^2)

h = reservoir thickness (m) (assume = aquifer thickness)

ρ = liquid density (kg/m^3)

Δw_j = change in fluid production rate at time j (kg/s)

$$\sigma = 2 \frac{c_a}{c_r}$$

c = compressibility (1/Pa)

$$N\left(\sigma, t_D - t_{Dj}\right) = L^{-1} \left| \frac{K_0(\sqrt{s})}{s^{3/2}(\sigma K_1(\sqrt{s}) + (\sqrt{s})K_0(\sqrt{s}))} \right|$$

$K_{0,1}$ = Modified Bessel Function of zero and first order.

$$t_D = \frac{kt}{\varphi\mu_a c_a \tau_r^2} \text{ for } t \text{ equals } t_n \text{ (seconds)}$$

$$t_{Dj} = \frac{kt}{\varphi\mu_a c_a \tau_r^2} \text{ for } t \text{ equals } t_j \text{ (seconds)}$$

φ = porosity

subscripts: a = aquifer, r = reservoir

In order to solve the equation, estimates of all of the above parameters must be made. Unless otherwise denoted by a subscript, a parameter is assumed to have the same value in the aquifer and reservoir (permeability, k, for example). The summation intervals represent the times at which different flow rates become effective. Time n is the total time of production. The value of the function N is determined by inverting the given expression from Laplace space. While an analytical solution is not available for this inversion, it is accomplished by use of the Stehfest Numerical Inversion Algorithm which appears in the computer listing in Appendix A. Using this equation it is possible to evaluate the effects of different production (w_j) schedules on reservoir drawdown (and hence deliverability).

Equation 3.1.1 is composed of many reservoir parameters. However, for simplicity, they can be combined into just three constants as is shown below.

$$\Delta p = K \sum_{j=0}^n \Delta w_j \sigma N\left\{\sigma, TC(t_n - t_j)\right\} \quad (3.1.2)$$

where: $K = \frac{Pa}{2\pi kh\rho_a}$

$$TC = \frac{k}{\varphi\mu_a c_a \tau_r^2}$$

$$\sigma = 2 \frac{c_a}{c_r}$$

In Equation 3.2.2, the terms are the same as given for Equation 3.1. However, the three constants K , TC and σ are identified. These are the parameters which must be estimated in order to predict the performance of the reservoir, or varied in order to match the history of the reservoir.

This model contains no energy balance and assumes flow of constant-enthalpy liquid in the reservoir. Over a twenty year period the production may constitute a large fraction of the liquid mass of the reservoir. Thus, it is clear that large amounts of recharge must occur. Due to this large influx of water there is a possibility that the enthalpy of the fluid will change with time. However, the heat content stored in the rock, in combination with sufficient residence time, could make the constant enthalpy assumption reasonable.

Adding energy effects to the reservoir model certainly would constitute an improvement. However it is shown in this analysis that just by considering the reservoir drawdown, which plays the most important role in the ability of the reservoir to deliver the geothermal fluid, regardless of its enthalpic value, important conclusions can be drawn about the economic performance of the development.

There are several other advantages in using this type of a model. Because it describes a single element of reservoir behavior which depends mainly on the gross features of the reservoir, the reservoir can be characterized adequately by homogeneous properties and simple geometries. This is appropriate in the early stages of development when the data is usually unavailable for more complete reservoir definition or simulation. In addition, the model incorporates the dominant features influencing reservoir drawdown in a functionally simple form. For example, the contrasting compressibility between the reservoir and the aquifer is simply characterized by the ratio of the two. Thus, the absolute magnitude of either compressibility, which can be difficult to predict and measure, is not as important in the formulations their ratio. Finally, if high permeabilities are found in the geothermal

reservoir then the entire reservoir can react very quickly to a local pressure disturbance within its volume. This would tend to make the reservoir behave as one "lump."

However, it must be remembered that there are severe limitations as well. One of these is the lack of an energy balance. Another is that the model considers recharge from only the flanks of the reservoir and does not consider the possibility of recharge (both mass and heat) from underneath or above. Most importantly, no heterogeneities are modeled in the reservoir.

3.2 Reservoir Inflow Performance

In the previous sections, the change in reservoir pressure due to fluid production was discussed. Reservoir pressure provides the driving force to move fluid to the well. The relationship between the flowing pressure in the well, P_{wf} , the reservoir pressure, P_{res} , and the flow rate is called inflow performance.

Figure 10 is an example of the inflow performance curve for flow through a liquid dominated reservoir. Before discussing the construction of this curve, it is helpful to describe its characteristics. As indicated in the figure, the effect of decreasing the *downhole* well flowing pressure (P_{wf}), at a fixed reservoir pressure, is to increase the mass rate into the well since the total pressure drop between the reservoir and well would increase.

This inflow performance curve is a composite of two forms of flow behavior, depending upon whether the flowing pressure is above or below the saturation pressure. Above the saturation pressure there is a linear relationship between the mass rate and P_{wf} . Below the saturation pressure, the slope of the curve becomes more and more negative. This indicates that below the saturation pressure, decreases in P_{wf} become less effective at increasing the mass rate into the well.

The well flowing pressure represents the pressure in the well opposite the feed

zone. Furthermore, it presupposes that this feed zone is dominating flow into the well and that there is no interzonal flow. The intercept of the inflow performance curve with the P_{wf} axis indicates the current reservoir pressure.

The linear relationship between the flow rate and well flowing pressure has been described in the geothermal literature (Ryley²¹). The inverse slope of the linear portion of the inflow performance curve is the productivity index (PI) which has been described by Gudmundsson.²⁰ A constant productivity index would imply a constant slope to the inflow performance curve as is shown in the Figure 10 for pressures above the saturation pressure. Dake²² discusses the productivity index in relation to petroleum reservoirs.

However, if the saturation pressure is reached in the streamline to the well, then the constant relationship between decreasing well flowing pressure and flow rate no longer applies. There are several reasons for this. When flashing occurs in the reservoir a steam phase is formed. The steam phase will preferentially flow towards the well when compared to the liquid phase. This decreases the average fluid density entering the well. It also increases the enthalpy of the fluid because heat is transferred from the rock matrix to the fluid when the water vaporizes. Another possibility is that turbulent flow can result. This would increase the pressure drop due to frictional forces and once again decrease the liquid mass flow-rate into the well. Finally, if the flow reaches choked conditions then further reduction in P_{wf} has no effect upon flow rate. This topic was investigated by Menzies, Gudmundsson and Horne²³. They concluded that "choked flow is a possible explanation for the constant massflow and increasing enthalpy noted in the output characteristics of some geothermal wells."

Regardless of which of the above phenomenon is present, the effect upon the inflow performance curve is to cause it to show increasingly negative slope with decreasing P_{wf} as is shown in Figure 10. The problem at hand is how to model these

effects in a general way.

The petroleum literature presents analysis of an analogous form of flow in petroleum reservoirs called solution gas drive. In a petroleum reservoir, when the pressure drops below the bubble point of the oil, gas will come out of solution with the same relative permeability and "turbulence" effects as noted above. In this case the gas flows preferentially towards the well and greater pressure drops are required than would normally be expected.

Vogel²⁴ presented a dimensionless curve relating flowing pressure to the flow rate in solution gas drive reservoirs. Fetkovich²⁵ and Brown²⁶ discuss the Vogel inflow performance relation for solution gas-drive reservoirs. The Vogel relation is:

$$\frac{q_o}{q_{o_{\max}}} = 1.0 - 0.20 \left(\frac{p_{wf}}{p_r} \right) - 0.80 \left(\frac{p_{wf}}{p_r} \right)^2 \quad (3.2.1)$$

where q_o is the producing rate corresponding to p_{wf} , p_r is the reservoir pressure, and $q_{o_{\max}}$ is the maximum possible producing rate. A graph of the Vogel relationship is given in Figure 1

The Vogel inflow performance curve for solution gas drive reservoirs is referred to as the IPR curve. It was derived from the results of computer simulations of flow in a solution-gas drive reservoir. The dimensionless IPR curve was then fitted to the results. Thus, it is an empirical relationship. There are some insights provided by its form. If the flow were linearly related to the pressure drop then only the first two terms of the equation would be present and the coefficient of the p_{wf}/p_r term would be one. However, the full form of the equation includes a $(p_{wf}/p_r)^2$ term. This indicates that non-linear flow effects, such as those cited above, significantly influence the flow. The coefficients of the terms indicate that 20% of the increase in flow rate is linearly dependent on the pressure drop while 80% is due to the non-

linear effects. Thus, this is a general equation which could generally apply in any flow situation where the non-linear flow effects are expected to dominate.

For the geothermal liquid-dominated reservoir, the non-linear flow effects are only expected to be appreciable at flowing pressures less than the saturation pressure. Therefore, the IPR curve might only be expected to apply for P_{wf} lower than the saturation pressure.

Consequently, the Vogel relationship was applied for flows below the saturation pressure. The linear region was joined with the non-linear region with the condition that the slope (or productivity) where they connect (at the saturation pressure) must be equal. As a result, further pressure drops below the saturation pressure do not result in the increase in flow rate that would be expected from an extrapolation of the linear IPR relation. The productivity index is decreasing with decreasing well flowing pressure in this region.

Since the IPR only applies to flow below the saturation pressure, the form of the equation changes slightly. It now becomes:

$$\frac{\Delta w}{\Delta w_{\max}} = 1.0 - 0.20 \left(\frac{p_{wf}}{p_{sat}} \right) - 0.80 \left(\frac{p_{wf}}{p_{sat}} \right)^2 \quad (3.2.2)$$

where p_{sat} is the saturation pressure, Δw is the incremental mass flow rate above that which occurs at $p = p_{sat}$, and Δw_{\max} is the maximum incremental mass flow rate which occurs at $(p_{wf} / p_{sat}) = 0.0$. The maximum incremental flow rate, Δw_{\max} , can be simply found from the linear portion of the inflow performance curve. The slope and value of the IPR portion of the reservoir performance curve is equal to that of the the linear portion at $(p_{wf} / p_{sat}) = 1.0$. If the linear portion is extrapolated to $(p_{wf} / p_{sat}) = 0.0$, then Δw_{\max} will be 56% of the additional flow indicated by the linear extrapolation. This is shown in Figure 12.

The entire inflow performance curve can be determined if the reservoir pressure and saturation pressure are known and if one measurement of the mass rate and Pwf is made. The inflow performance curve is constrained to go through the reservoir pressure on the ordinate and would also have to pass through the measured point.

Another way to construct an inflow performance curve would be to perform a series of flow tests at different rates and measure the stabilized well flowing pressure at each rate. This would provide direct measurement of the inflow performance and serve as a way to verify its shape for other wells in the same field. **Butz**²⁸ and **Menzies**²⁷ report on such a series of flow test performed at the Roosevelt Hot Springs on well Utah State 14-2.

The results of these measurements is presented in Figure 13. With the exception of the one point, the data seem to match the form of inflow performance curve. In this case, the inflow performance curve was constructed by using the productivity index and the saturation pressure reported by **Butz**²⁸. This determined the linear portion of the curve. The Vogel IPR portion was constructed as discussed above. The constant slope portion of the curve has a slope of 0.025 MPa/tonne/hr which corresponds to a productivity index of 40.0 tonne/hr-MPa (= 600 lb/hr-psi). **Gudmundsson**²⁰ reports a productivity index of 96 tonne/hr-MPa (= 1456 (lb/hr-psi) for a well in the Svartsengi field. There were not many measurements made below the saturation pressure so the shape of the curve is not as well defined. It may be that the flow is choked, as suggested by **Menzies**²⁷, or perhaps drops off faster or slower than predicted by the Vogel IPR. In either case, it seems reasonable to account for diminishing changes in mass rate with decreasing pressure below the saturation pressure.

The inflow performance of the reservoir is constant over short periods of time. As the reservoir pressure drops due to fluid production, the inflow performance curve will tend to shift downward. The new performance curve will be parallel to the old.

This is because it is the *difference* in pressure between the reservoir and the well which gives rise to flow to the well. A series of inflow performance curves, all applicable to the same reservoir at different reservoir pressures, is shown in Figure 14. These particular curves were derived from the data presented by Butz and Plooster⁶ and Butz.²⁸ and are not generally applicable to other reservoirs. However, such curves could be constructed for any liquid dominated reservoir using the technique described above.

If the reservoir pressure is known at any point in time, either through direct measurement or by way of water influx modeling, then the appropriate inflow performance curve can be used to determine flow into the well from the reservoir for a given Pwf. Thus, the Hurst water influx model can be used in conjunction with the inflow performance curve to give the flow into the well at a given Pwf. In the following section, the flow through the well to the surface is analyzed to complete the description of field deliverability.

3.3 Well Performance

In this section, the flow from the reservoir to the surface is described. The characterization of flow through the well is called well performance. Well performance describes the complex multi-phase flow which occurs in geothermal wells. If well performance is expressed in a graphical form, it can be easily combined with reservoir inflow performance curves to predict field deliverability.

The goal of well performance curves is to relate the well flowing pressure to the mass rate from the well. To do this, the multi-phase (or single phase) flowing pressure drop through the well must be determined. Many correlations exist for multi-phase flow. However, none seem to have emerged as a generally acceptable technique. For the development model, well performance curves were constructed from measure values of mass rate and well flowing pressures presented by Butz and Plooster⁶ and Butz²⁸. Thus, the well performance curves employed here are particular

to Well Utah State 14-2 of the Roosevelt Hot Springs, Utah, U.S.

Butz²⁸ presents the equation;

$$\Delta p_{flow} + \frac{w}{P.I.} = p_r + p_{wh} \quad (3.3.1)$$

where Δp_{flow} is the two phase pressure drop through the well, w is the mass rate, $P.I.$ is the productivity index, p_r is the reservoir pressure, and p_{wh} is the wellhead pressure. Note that $\frac{w}{P.I.}$ yields the pressure drop in the reservoir. Thus, the equation states that the total pressure drop from the reservoir to the wellhead is equal to the sum of the pressure drop in the reservoir plus the pressure drop in the casing.

Figure 15 is from Butz²⁸. It gives the mass flow rate as function of well outer diameter and productivity index for a fixed surface pressure of .69 MPa (100 psia). The depth of fluid entry into the well was about 900 meters. The temperature of the reservoir was about 250 °C and the fluid enthalpy equals 1100 kJ/kg. Butz and Plooster⁶ indicate that the reservoir pressure was about 9.7 MPa (or 1430 psia). Thus, using the values from Figure 15, the two phase flowing pressure drop could be calculated using Equation 3.3.1. Table 2 gives the values from the calculation of the pressure drop.

The values of p_{wf} vs. mass rate from Table 2 are plotted in Figure 16. A smooth curve has been fitted to the data points. They indicate that as the well flowing pressure increases, the mass rate increases, since the pressure drop in the casing increases. In multi-phase flow the head, friction, and acceleration all contribute to the total pressure drop and all vary depending upon the ratio of gas to liquid. Generally, the head is the most important factor, friction has some contribution at high flow rates, and acceleration has a negligible effect on the total pressure drop. It would be difficult to extrapolate the curves much further than is shown in Figure 16.

However, a limit to the mass rate capable of being carried by the pipe exists. Thus, the curves should tend to bend upward to the vertical, indicating the limit of flow for the given conditions.

These well performance curves are specific to the fluid conditions, surface pressure and depth specified on Figure 16. Curves like this could be constructed for any set of flowing conditions. To do this, some technique is required to predict (or measure) the two phase flowing pressure drop in the well for different flowing conditions. This would be necessary to explore the effect of different well designs on deliverability. For the development model presented here, the choices are limited to those investigated at Roosevelt Hot Springs. As Figure 16 indicates, only the difference between the two casing sizes will be discussed. In the following section, the connection between reservoir inflow performance, water influx modeling of reservoir pressures, and well performance is discussed.

4. MODELING DRAWDOWN AT WAIRAKEI AND AHUACHAPAN

The Hurst water influx model has been compared with the production-drawdown data of several geothermal liquid-dominated field developments. **Olsen**¹⁰ used the production history of the Svartsengi reservoir for history matching and prediction. For this study, a similar approach is taken with Wairakei and Ahuachapan production data. The result of the comparisons provide a means of introducing real field characteristics into the development model.

4.1 Wairakei History Match and Prediction

The Wairakei reservoir has been the subject of many studies. **Fradkin**, **Sorey** and **McNabb**¹⁷ and **Fradkin**¹⁸ provide data and descriptions of the Wairakei reservoir. These studies were used as the source of the reservoir parameters which were needed for the Hurst model. These values are given in Table 3. In the case of compressibility and viscosity, the aquifer and reservoir values were taken from **Olsen's**¹⁰ description of the Svartsengi reservoir. These depend primarily on the fluid characteristics and reservoir temperature, which are similar for the two systems.

The production data was modified before using it with the model. In the earliest years of exploration and testing the production is apt to be very small and inconsequential when compared to the volume of the reservoir. This production can take place with little or no drawdown observed in the reservoir. It is difficult to get the model to match a period with little mass withdrawal and no drawdown. For this reason the production is considered only after some measurable drawdown has occurred in the reservoir. When full-fledged production begins, the drawdown becomes quite apparent. For Wairakei the drawdown is first clearly seen in 1956, as seen in Figure 17, (Love and Bolton**). In their studies, **Fradkin**¹⁸ and **Fradkin**, **Sorey** and **McNabb**¹⁷ also ignored the early data and started their analysis with the production data from 1958.

At the start of a project, production data simply are not available. Under these circumstances, a water influx model might be needed to predict the reservoir drawdown under several different scenarios of production. If estimates of the reservoir parameters shown in Table 3 are available, then such a prediction can be made. Furthermore, the effect of varying reservoir parameters can also be explored.

A prediction of the Wairakei pressure drawdown was performed with values for reservoir properties given in Table 3 and production as shown in Table 4. The first step in this procedure is to calculate the three constants, TC, K, and σ , required by the Hurst model. When the values of the reservoir parameters from Table 3 are inserted into the definitions of the constants given in Equation B the results are: $\sigma = 0.57$, TC = 0.008 (1/days), and $K = 7.07 \times 10^{-4}$ (MPa-s/kg). These three constants describe the reservoir and are all that is required to determine the drawdown in the reservoir given a production schedule. The second step is to run the program Hursgraphrad (Hurst-graph-radial). It prompts for the values of the three constants required by the Hurst formulation and reads an input file which gives the time (days) since production began, the mass rate of production (kg/s) over the latest time interval, and the measured drawdown (for graphing in comparison to calculated values). The program calculates drawdown according to Equation 3.1.2 which is the mathematical form of the Hurst simplified relation. The output file contains the predicted value of drawdown as well as the measured values of drawdown. The program and a sample of the input and output files are given in Appendix A.

Figure 18 is a graph of the predicted and actual values of drawdown in the Wairakei field. The predicted values of drawdown are uniformly higher than the actual values. This indicates that the prediction of reservoir behavior underestimated the ability of the reservoir to sustain pressure. This could arise in several ways. One is if the recharge from the supporting aquifer was much greater

than the model predicts. This may be a reflection of the high energy of geothermal systems, which could conceivably drive recharge at a greater rate than would occur only due to the compressibility of the supporting aquifer. It may also be that the storativity of the reservoir, that is the product of porosity, thickness and compressibility, is greater than the values from Table 3 indicate. In this case, the expansion of fluid from within the reservoir would be greater than was calculated.

In either case, the results of the prediction suggest that the Hurst model is useful as a predictive tool. One reason is that, although the calculated values differ from the actual values, they do so in a conservative fashion. By overestimating the drawdown the Hurst model is conservatively estimating the ability of the reservoir to deliver geothermal fluid, since higher reservoir pressures go along with greater production rates. Another reason is that the calculated values tend to plateau at about the same amount of cumulative production as the actual values. This suggests that the model can be used to predict the level of cumulative production where steady conditions are reached in the reservoir, even if the magnitude of the value is off.

The model was used to history match the data too. A program called Hursradfit (Hurst-radial-fit) was written to accomplish this. The program prompts for the values of the two constants TC and σ . The production data should be input in the same format as described above for the Hursgraphrad program. Initial estimates of these are calculated in the same manner as shown above for the prediction. It then assigns the value of the third constant, K , in such a way as to minimize the square of the differences between the observed data and the calculated values. It is able to do this because, once the values of the first two have been constrained, there is only one selection for the third, K , that will minimize the square of the differences. A standard deviation between the observed data and the calculated drawdown is output to be used to select the best match between the calculated values and the

actual values. The program, a sample input file and a sample output file are presented in Appendix B.

Over successive runs the two constants are varied until the best match is obtained between the calculated and actual values. When performing this type of match it quickly becomes apparent that the matches are non-unique. Table 5 gives the values of the model constants used for two separate matches of the Wairakei data. Judging by the standard deviation criterion, **also** given in Table 5, the two matches are close and produce equally good calculations of drawdown. However, the actual match parameters differ by as much as 38%. Match 2 could **represent** the case of a small, highly compressible reservoir while the other corresponds to a larger not-as-compressible reservoir. What match 2 lacks in size **it** makes up for in compressibility.

In light of the non-uniqueness, one must decide which of the parameters should be varied in order to achieve the match. Permeability is often used as the variable parameter when matching field data. In that case, the Hurst constant TC and K would be varied to achieve the match. However, as demonstrated by the prediction of Wairakei drawdown, the compressibility could be just as influential in the drawdown behavior of the reservoir. This is especially true if boiling is occurring in the reservoir. Grant, Donaldson and Bixley¹⁹ estimate the compressibility of liquid on the order of 10^{-9} (1/Pa), and steam on the order of 10^{-7} (1/Pa). In the presence of boiling, the compressibility may be on the order of 10^{-6} (1/Pa) due to the effect of phase change. This range of several orders of magnitude will have a pronounced effect upon the σ constant in the Hurst formulation since the reservoir compressibility appears in the denominator. Therefore, the σ term was varied to achieve the match with the field data. Aside from reservoir compressibility, **all** other reservoir and aquifer parameters are considered known and **all** variation in the σ term needed to achieve the match is attributed to reservoir compressibility.

History matching was performed in two ways. One method was to employ the entire field production and drawdown data in the match. In the other method, only some early portion of the production data, say the first four years, is used to match the model. Then, the resulting matched parameters are used to "forecast" the remaining drawdown from the remaining production history. In so doing, the match from the first portion of the data is checked by trying to predict the second portion of the data. This tests the forecasting ability of the model against actual field performance. It also suggests how long it takes the model to "look in" to the behavior of the reservoir.

The results from matches done in this manner are shown in Figure 19. History matches were performed on the Wairakei data using 3 years, 6 years, 12 years and 25 years of the 25 year data set. Values for the reservoir compressibility from each match, solved for with the value of σ for each match and $c_a = 2.4 \times 10^{-9}$ (1/Pa), are given in Table 6. After three years the match is decent but, as with the pure prediction, somewhat overestimates the drawdown. Matches using the first six years of production data or more were all very close to the actual reservoir drawdown over both the matched and forecasted interval. Thus, at the six year point, enough data was available to accurately forecast the next twenty years of drawdown from production.

The values of reservoir compressibility calculated from the match correspond to the unconfined aquifer case presented in Grant, Donaldson and Bixley.¹⁹ This could be explained as a liquid reservoir overlain by a steam cap. It appears from this result that boiling does not significantly influence the compressibility of the Wairakei reservoir. The reservoir compressibility determined from the match is averaged over the time of production. As is seen in Table 6, the reservoir compressibility apparently is highest in the three year match, then decreases for the six and ten year match, and then slightly increases for the full history match.

4.2 Ahuachapan Prediction and History Match

The same predictive and matching procedure described above for the Wairakei reservoir was performed for the Ahuachapan reservoir. Production and reservoir data was provided by Quintanilla¹⁴ and Vides¹⁵, Table 7 presents the reservoir and aquifer parameters used in the Hurst match and Table 8 presents the production data for the reservoir. Using the values of Table 7, the Hurst constants are;

$$TC = 0.039 (1/day)$$

$$\sigma = 0.40$$

$$K = 1.36 \times 10^{-3} (MPa-s/kg).$$

Since this reservoir is similar in size to the Svartsengi reservoir, the initial estimate of reservoir compressibility was taken to be about the same as indicated by the match of Svartsengi production done by Olsen.¹⁰ In addition, the aquifer water density was taken as 850 kg/m^3 due to indications of hot water recharge.

Figure 20 is the result of the prediction of drawdown in Ahuachapan reservoir. As in the case of Wairakei, the predicted drawdown is greater than the actual drawdown. However, as with the Wairakei prediction, the shape of the predicted curve is similar to that of the actual data. This reservoir was produced at extremely variable rates, as indicated by Table 8, which makes the job of prediction and matching that much more difficult.

Figure 21 gives the graphical results of the history matching done on the Ahuachapan reservoir. Table 9 shows the Hurst constants and reservoir compressibilities found from the matches. The three year match is noteworthy. The best 3 year match was achieved by drawing a straight line through the first three data points (corresponding to the first three years). Thus, the forecasted drawdown behavior for the next 10 years was also a straight line with respect to cumulative

production.

This straight line behavior represents a limiting case of the Hurst radial solution. In this limiting case, the match between the actual and predicted drawdown gets better as $\sigma \rightarrow 0$ and the Hurst formulation has an analytical inversion from Laplace space which reduces to;

$$\Delta p = \frac{W_p}{V \phi c_r \rho_r} \quad (4.2.1).$$

In the above expression all terms are as previously defined and V is the bulk volume of the reservoir. The implications of this limiting case is that the aquifer plays no role in the drawdown behavior of the reservoir. Taking the slope of the straight line from Figure 21 and setting it equal to $1/V \phi c_r \rho_r$ it is possible to solve for the reservoir compressibility. This is the result given in Table 9.

As with the Wairakei matches, the reservoir compressibility starts out high, then drops for the seven year match, and finally increases again for the full history match of 13 years. However, in this case the magnitude of the reservoir compressibility is like that of steam. It seems from this result that boiling has a significant effect on the drawdown behavior of the Ahuachapan reservoir.

The results from comparing the two sets of field data to the Hurst water influx model indicate that the model matches the actual behavior of drawdown in reservoir. Moreover, using the three Hurst constants found from the full history match for the two reservoirs provides two examples of observed reservoir behavior. These are used in the development model to represent two cases for possible outcomes in reservoir behavior, namely, a reservoir (Ahuachapan) where boiling effects dominate the drawdown behavior and a much larger reservoir (Wairakei) where the dominant compressibility effects are from the liquid storage in the reservoir.

5. DETERMINING FIELD PRODUCTIVITY

In this chapter the water influx model, the reservoir inflow performance, and the well performance are linked to determine the productivity of the field. The advantage of breaking the problem into these components is to allow separate treatment of the reservoir and well in determining productivity. As will be shown, depending upon the characteristics of the reservoir, well design can have a large influence upon the productivity and hence the economic performance of the development. In other cases it is of relatively little importance.

Figure 22 shows a combination of the reservoir inflow performance curve presented in Figure 10 and the well performance curves presented in Figure 16. A dashed line is drawn from the point of intersection of the inflow and well performance curves to the abscissa. The mass rate from the two types of wells is indicated by where these dashed lines meet the axis. The 9 5/8 inch well would produce at about 220 tonne/hr while the 13 3/8 inch well would produce at about 260 tonne/hr. Well flowing pressure would be about 3.3 MPa for the 9 5/8 inch well and 2 MPa for the 13 3/8 inch well.

It is important to remember the conditions that went into determining these flow rates. First, with regards to the inflow performance curve, the reservoir pressure is 9 MPa as indicated by the intersection of the inflow performance curve with the well flowing pressure axis. The productivity index of the reservoir, above the bubble point pressure, is 40 tonne/hr-MPa, while below the saturation pressure it is determined by the Vogel IPR relation. The two casing performance curves were determined for a fluid of about 1100 kJ/kg enthalpy flowing from a depth of 900 meters to a constant surface pressure of about 0.69 MPa.

Assume that these conditions exist at the start of production. As production continues, the reservoir pressure will decrease. The water influx model, in this case the Hurst Simplified model, provides the new reservoir pressure. At the new

conditions the well performance curves look the same since the **assumption** of constant enthalpy fluid production has been made and all other factors for the well remain unchanged. However, the reservoir inflow performance curve will change. As before, the inflow performance curve is constrained to pass through the reservoir pressure. The productivity index, or slope of the IPR, does not **depend** upon the reservoir pressure. Consequently, the IPR will shift downwards so that it is parallel to the old curve but passes through the new reservoir pressure point **given** by the water influx model.

Figure 23 shows the family of reservoir inflow performance curves generated as the reservoir pressure decreases. The intersection of inflow and well performance curves for each reservoir pressure indicates how the productivity of the well decreases over time. If the points of intersection are plotted on a graph of reservoir pressure versus mass rate, a curve can be fit that will give the mass rate from the well as a function of reservoir pressure. Such a curve is presented in Figure 24.

In this case, the curves are relatively straight, but this will not always be the case. If the intersections occur where either the inflow or the well performance are curving severely, then the relationship between reservoir pressure and mass rate will also be non-linear. A straight line drawn through the points of Figure 24 gives a functional form for the productivity of the well at any given reservoir pressure. The equation of the line for the 9 5/8 inch well is:

$$w = (31.38)p_r - 59.85 \quad (5.0.1)$$

where w is the mass rate from a well in **tonne/hr** and p_r is the reservoir pressure in **MPa**. It is this equation which is used by the development model to relate reservoir pressure to a well's productivity. The field productivity is **simply** this well productivity times the number of wells in the field.

In this case, there is little difference between the productivity of the 9 5/8 inch well and the 13 3/8 inch well. This situation has come about to the low productivity index of the reservoir; the inflow performance curve has a steep slope and consequently it crosses the two casing performance curves at about the same value of mass rate. A more productive reservoir would have a smaller slope. Figure 25 shows the inflow performance curve generated using the value of productivity index given by Gudmundsson²⁰ for the Svartsengi reservoir. It is apparent that there is a big advantage to drilling the 13 3/8 inch well since the productivity of the well increases from 240 tonne/hr to 335 tonne/hr. However, as is done with the development model, the additional costs (if any) for drilling a larger hole must be balanced against the benefits of having more productive wells.

The field deliverability of the development model is a combination of observed field behavior in several different reservoirs. It has the drawdown-production behavior of Ahuachapan or Wairakei and the reservoir inflow performance and well performance of Roosevelt Hot Springs. The deliverability of the resultant conglomerate field is well within the range of field deliverability seen in the world data presented in Chapter 10, and often near the average. So the development model results are not unusual in terms of field deliverability, and the economic effects of field deliverability. Fields with greater deliverability would show less effect of deliverability on development cost than indicated by the results from the development model, while fields with lower deliverability would show more effect.

6. POWER PLANT

There are numerous forms of power plant technology available for the conversion of geothermal fluids into electricity. Kestin²⁹ detailed the used power systems. In general these are; flashed steam and steam turbine systems, which can have more than one flashing stage; binary cycles, which utilize some working fluid other than the geothermal fluid in a turbine; hybrid fossil-geothermal systems; and total flow systems, which utilize all of the produced geothermal fluid for electricity generation.

With such a diverse group of technologies, a simple yet all-encompassing method for describing and equating their performance is required. Such a method is presented by DiPippo³⁰ and Kestin.²⁹ Employing the second law of thermodynamics, they describe a method of analysis based on an "available work" or "exergy" analysis.

Kestin²⁹ presents the equation:

$$\frac{\dot{W}}{w} = \left[h_1 - \sum \frac{w_i}{w} h_{2i} \right] - T_0 \left[s_i - \sum \frac{w_i}{w} s_{2i} \right] - T_0 \Theta \quad (6.0.1)$$

where \dot{W}/w is the work rate divided by the mass rate (or specific work), h is the enthalpy (energy/unit mass), T_0 is the temperature of the ambient conditions, s is the entropy, and Θ is the entropy production per unit mass of brine. The subscript i refers to the n streams of geothermal fluid, 1 refers to the initial state of the geothermal brine and 2 refers to the final state of the fluid.

Kestin²⁹ states that Equation 6.0.1 is valid for any working fluid, includes the effects of pressure and temperature of the working fluid, the temperature and pressure of the surroundings, the change in composition and phase of the working fluid, and the change in elevation and flow velocity. DiPippo³⁰ presents an analysis of dry steam plants, a binary plant and a dual-flash plant using this technique. As

shown below, the simplifying assumptions used in this work make application of this technique extremely easy in the cases examined here. However, it can also be used for more complex situations.

In this study, only the conventional single flash power plant is considered. Although this technology has been employed for years, it has recently become available in a new form, wellhead generating units. The conventional "central" plant has been well described and will not be discussed here, except as to its characterization in the development model. However, the wellhead (or portable or modular) generating unit is still going through the process of gaining industry acceptance and use.

McHugh-Bodylski³¹ presents an overview of geothermal wellhead units. The author states that these units are distinguished by several features. They are situated next to a production wellpad and supplied with geothermal fluid from one or several wells. They generally are in the 1 to 15 MWe range but can be purchased in a 25 MWe size. They are fed by very short steam lines from the wells. Finally, modular construction techniques are used to build them.

McHugh-Bodylski³¹ lists the advantages and disadvantages of the wellhead units. Among the advantages are its short assembly period, its portability, and the decreasing of risk by operating with a small unit to obtain information about the resource. She also mentions the factory assembly and testing, and range of unit sizes as advantages. Among the disadvantages are the increasing cost per kilowatt of installed power with decreasing unit size. However, the author points out that this is offset by labor savings in the field during plant construction and start-up.

In the end, the differences between wellhead units and central plants are blurred. Central plants of a 25 MWe size, and smaller, exist. Wellhead units can be just as efficient as central plants. There is even doubt as to the relative Cost per kilowatt installed between the two types of plants.

For the development model, two items are necessary with regards to the wellhead single flash plant and the central single flash plant. One is the efficiency of the plant in converting the flow of geothermal fluid into electricity. The other is the impact of the two types of plants on development cost. Several field studies describing wellhead units and central plants were reviewed in order to characterize these two items. Development cost is discussed in a later section; plant efficiency is described below.

In order to characterize the conversion efficiency of a plant, equation H is utilized. There is only one inlet condition examined in this development model, that of a geothermal fluid of 1100 kJ/kg enthalpy separating at 0.69 MPa. Thus, the quality is fixed at about 22%. This separator pressure is taken to be the same as the surface, or wellhead pressure, used to construct the well performance curves. Any effect due to fluid transmission is thus ignored. This will tend to benefit the analysis of central plants relative to the wellhead units because, as was pointed out, the wellhead units generally have very short transmission lines.

Furthermore, any pressure drop between the separator and the inlet into the turbine is ignored. The exhaust conditions are of two forms. One is for a condenser where the exhaust pressure is about 0.01 MPa. The condenser option exists for both the central and wellhead plants. The other exhaust condition is for a turbine exhausting to the atmosphere, or a back-pressure turbine. For this analysis, only wellhead units were considered for back-pressure operation.

For known inlet and exhaust conditions and turbine design, the right hand side of Equation 6.0.1 is a constant. Thus, the plant efficiency can be expressed in the form of the left hand side, the specific work. The units of specific work are work rate (or power) per mass rate. This can be expressed as MWe per tonne/hr of saturated steam. Manufacturers data² and field studies⁴ provided the value of the inverse of the specific work, called conversion efficiency. For the inlet and outlet

conditions specified above the condenser option has a conversion efficiency of about 8 tonne/hr-MWe and the back-pressure option has an efficiency of about 15 tonne/hr-MWe. The back pressure option conversion efficiency could vary dramatically if favorable atmospheric exhaust conditions were available.

7. DEVELOPMENT COST

Development cost provides the economic criterion for deciding the best strategy in the development model. While this is not the only possible criterion, it does seem to be one common method for discriminating between possible geothermal development strategies. A careful definition of the costs to be included, and the magnitude of these costs, must be provided. The following sections outline the method of evaluating development costs used in this study. The objective is to take the different physical elements of the development discussed so far and assign a cost to each.

7.1 Estimating Cost in Geothermal Development

Geothermal power production is often used for baseload generation. From this perspective, the objective is to generate power up to a minimum baseload demand limit set by the market. There may be several generation options for baseload power. Accordingly, from a societal standpoint, it is desirable to meet the baseload demand with the cheapest mix of generation possible. If the marginal cost of power generation from one source becomes greater than that of the next best alternative, then the cheaper alternative is desired, *if* there is unused capacity in the cheaper alternative. For these reasons, studies evaluating the economics of geothermal power generation emphasize the cost of generation, both in comparison to other geothermal projects, different strategies for one geothermal project, and other generation possibilities.

Several field **studies**^{4,32,33,34,35,36} detailing the cost of geothermal development were used in this study. These reports were a New Zealand report on small plant geothermal power generation (**Southan**⁴), reports about central plant development at Cerro Prieto, Mexico and portable plant development at **Los** Azufres, Mexico (**Hiriart**^{32,33}), a report about central plant development at **Hengill**, Iceland (VGK Consulting³⁶), a report contrasting small and central plant development at The

Geysers, California, U.S.A. (Gibbs and Hill, Inc.³⁵), and an EPRI report on Heber California, Valles Caldera, New Mexico, and Raft River, Idaho, U.S.A. (Holt and Ghormley³⁴). The field studies are in terms of different currencies and from different times. The conversion from other currencies to U.S. currency was made with figures supplied in the studies, or by the author, when possible. With the exception of the EPRI report, the costs were in the period 1982 to 1985 and no adjustment was made to them. Costs from the EPRI report, dated 1976, were updated to 1984 levels using data on drilling costs from the Oil and Gas Journal.^{38,39}

These reports^{4,32,33,34,35,36} differed as to what constituted a cost of development, the magnitude of the costs and the method for determining the total cost of development. They had in common the consideration of initial investment cost for property, plant and equipment for both the steamfield and the power plant. They also shared a consideration of the annual expenses involved in operating the geothermal project, such as operations and maintenance of the facilities at the plant, transmission lines and wells, and other extraordinary "annual" expenses such as well workovers and replacement wells. However, they also had differing techniques for determining the cost of the development, and consequent cost of power generation, given the above common starting points in cost consideration.

Two major factors emerged which gave rise to the differences in cost determination. These were the form of ownership of the project and the operating constraints on the project. Two forms of ownership are commonly found in geothermal development. In one, the project is divided into two areas, the steamfield development and power plant development. Tester' discusses this topic. One firm, a reserve company, with expertise in the problem of fluid extraction from the earth, produces the geothermal fluid and sells it to the utility. The utility, either a private or public firm, takes the geothermal fluid ("fuel") and generates electricity. More risk is associated with the field development and fluid production. Consequently, the

producer will require greater rates of return than the utility will require, or be permitted, to receive.

The other form of ownership is a wholly-owned project. In this case, field development, production and generation are managed by one party. The fuel and generation costs, as well as financing, can be controlled in unison. Because the risk of field development and production is undertaken by the same group that generates the power, the risk premium required by a separate producer is avoided, resulting in different busbar costs of generation. Presumably, the joint type of development offers the advantage of risk sharing and assignment of types of risk to those best able to manage it, while suffering from the disadvantage of higher costs of power generation.

Because this work covers the entire project development process, and integrates factors like well design and power plant design, it is more appropriate to model the costs under a wholly-owned format. In this way the impact of plant design on productivity and, consequently, development costs can be evaluated. In addition, as was done for the field studies cited above, costs will fall into four categories, either plant or steamfield related and either initial investment cost or annual expense.

7.2 Steamfield Development Cost

The cost associated with steamfield development and production is a large fraction of total development cost. Tester' states that they usually amount to 50% or 60% of total capital cost, and can reach 75%. The field studies^{4,32,33,34,35,36} attributed a range of 25% to 50% of the total cost of power generation per kWh to steamfield development costs. Results from the development model runs made for this work indicated steamfield development costs from about 25% to 33% of total cost of generation. Regardless, this explains why the well productivity exerts such a strong influence on the cost of geothermal development. Most of the cost of

steamfield development is associated with the wells.

In order to model the steamfield development cost it is necessary to characterize the cost in terms of some easily measured "yardstick". In this study the number of production wells was used to characterize the amount of steamfield development. An average cost per production well of the steamfield, both initial investment cost and annual expense, was determined from the field studies. This approach lumps together the initial cost of drilling, completion, wellhead and transmission equipment, and then averages them over the number of production wells. Drilling costs appear to compose about half of this cost. On average, 2 1/2 production wells were required for each injection well. However, this ratio was as small as one production for two injection wells and as high as 5 1/2 production wells for each injection well.

Similarly, the annual steamfield expenses, such as operations and maintenance, and well workovers and replacement are normalized over the number of production wells. While operations and maintenance costs are truly annual expenses, items such as well workovers occur irregularly. In order to treat these irregular items as annual expenses, data about their occurrence and cost over the life of a project was discounted to the first year and then levelized on an annual basis. This spreads the cost of these irregular items in the form of equal annual payments (levelized payments) whose present value is the same as the present value of the Irregular costs. In order to levelize them, a project life and discount rate must be specified. A project life of 25 years and discount rate of 10% were picked for this study, which was in keeping with the values in the field studies. This annual steamfield cost is interpreted in the following manner. It is the amount expended each year on steamfield operations, maintenance, workover and other items associated with the ongoing costs of running and producing the steamfield. In the field studies the annual costs so determined were found to be about 8% to 9% of the initial steamfield

Investment.

About half of the annual steamfield cost per well was associated with operations and maintenance while the other half was associated with **workover** and replacement wells. Clearly, site-specific factors such as calcite **deposition** in the wells, will significantly effect the workover costs and replacement well Costs. Table 10 presents the steamfield costs derived from the field **studies**^{4,32,33,34,35,36}.

The development model assigns two types of cost when a new well is required. The first is the initial investment cost of the well and associated steamfield equipment. This is incurred one time only when the well is "drilled". **The** second is the levelized annual cost per well. This cost is incurred annually **starting** with the year the well is "drilled" and continuing until the project lifetime is reached. Thus, the annual cost is like an annuity which must be discounted to the **year** the well is drilled. In addition, if the well is drilled some time into the life of the project, then both the initial investment cost and the annual cost must be discounted to the first year of the project.

7.3 Power Plant Development Costs

Plant costs were handled in a manner analogous to that of **the** steamfield development. Both an initial investment cost and an annual cost were **determined** for the plant from the field **studies**^{4,32,33,34,35,36}. In this case the **MWe** of installed capacity was the "yardstick" used to normalize the size and cost of a plant. The initial installed capacity is multiplied by the initial investment cost per Unit installed capacity to determine the total initial investment cost of the **plant**. This total investment cost would include all items associated with the operation of the power plant.

Annual expenses were composed mainly of operations and maintenbnce. Unlike the case of the steamfield, there were no significant irregular items to **be** levelized

and included with the annual expenses for the plant. The annual plant costs were about 4% of the initial investment cost for the plant. Table 11 gives the values for annual and initial plant costs, broken down for central plants, wellhead plants with condensers, and back-pressure wellhead plants.

As the figures in Table 11 indicate, there is a wide range in reported costs for both types of plants. In addition, the range for the wellhead units is greater than, and covers, that of the central plants. In some of the steamfield studies, each wellhead unit was fully equipped with all the features of a central plant operating in an environmentally sensitive area. Duplication of environmental controls and other plant features tend to drive the cost per unit installed capacity very high in this case. Other operators considered very simple wellhead facilities which involved little more than a wellhead unit exhausting to the atmosphere with no environmental control or special fluid disposal measures. In that case, the cost per unit installed capacity was very low.

7.4 Calculation of Costs in Development Model

Central plants and wellhead plants receive slightly different treatment when determining cost in the development model. There is a broad enough range of plants that the available installed capacity in the central plants can be treated as continuous. Consequently, the initial investment and annual central plant costs will depend linearly upon the installed capacity. Wellhead plants are treated in a different fashion. As discussed in the section on plant modeling, a distinguishing feature of wellhead units is that they are connected to just one, or a few, production wells. To contrast these wellhead units in the strongest possible way with the central units, the smallest size compatible with the output from the wells was selected. This was a "5 MW" unit, although the actual generation would of course depend upon the mass rate of steam through the turbine. In addition, each wellhead unit was supplied by just one well. Thus, total generating capacity and development cost for the wellhead

units is added in small discrete steps.

Both plant costs and steamfield costs are incurred over time. All costs are discounted to find the net present value at the start of the project. Some of the field studies considered the start-up time in determining initial costs. In these field studies, design and construction time for the central plants was generally designated at about 4 to 5 years while for the wellhead units (in small numbers) it was estimated at about 3 to 4 years. Therefore, the cost of the delay in construction of the plant was built into the cost numbers used in this study.

For a project incorporating the central plant the total development cost would be calculated as follows. The initial plant investment plus the sum of the discounted annual plant costs was added to the discounted values of the initial steamfield invest cost plus the discounted annual steamfield costs. At the start of the project, the plant is built and the required numbers of wells are drilled to meet the "fuel" requirement. The annual costs for both the plant and the steamfield are discounted to present value. In addition, as the productivity of the steamfield declines, additional wells are drilled as needed to maintain the fuel supply. The initial cost of the additional wells drilled in the later years is discounted to present value terms along with the annual steamfield cost for the additional well.

For the wellhead development, plants and wells are installed at the same time in pairs. They are also added in pairs to make up for the decline in steamfield productivity. Additional wells and wellhead units added after the first year have their initial investment cost and annual costs discounted to the first year of the project.

Given the observed range in plant and steamfield costs, what values for initial and annual costs were used in the report? One goal for the study was to contrast the choice between central and wellhead plants. In order to provide the strongest possible contrast, the costs used in the report were purposely chosen to be favorable to the wellhead units. This was not done to suggest that the wellhead

units are truly cheaper, but only to provide a consistent and clear slant in the selection of the cost values. As was noted earlier, many site specific factors effect the costs.

An initial investment cost for central plants of 1.3 \$M/MWe installed was used. This was near the top end of the observed range of central plant initial investment costs. For the condenser wellhead units, a cost of 0.7 \$M/MWe installed was used. This was nearly the lowest of the observed values, but still higher than the low value for backpressure wellhead units. The lowest observed cost for the backpressure wellhead units, 0.5 \$M/MWe installed, was used. The size of the wellhead units was picked to be among the smallest of the packaged types of units available. According to manufacturers specifications this put them in the 5 MWe size. Consequently, the initial investment cost for each condenser wellhead unit was fixed at 3.5 \$M for the condenser wellhead plants and 2.5 \$M for each backpressure wellhead unit.

Annual costs of 0.03 \$M/yr-MWe for the central plant were used. The annual operating costs were 0.06 \$M/yr-MWe for the condenser wellhead units and 0.03 \$M/yr-MWe for the backpressure wellhead units. Thus, the condenser wellhead units had annual operating costs of 0.3 \$M/yr while the backpressure unit\$ had an annual operating expense of 0.15 \$M/yr. Steamfield costs were the same in all scenarios. A value of 2.2 \$M per production well and 0.3 \$M/yr in annual expenses was used.

8. USING THE DEVELOPMENT MODEL

The development model covers many aspects of a geothermal project. Since they can be site specific, it was important to try to select ones which would be common to any development, and of general interest. In this report, the development model is used to address some of these general, but important, features of development.

Perhaps the most important choice is in the sizing of the plant(s). Suppose baseload demand is sufficient to cover any possible level of power generation from the reservoir. What imposes the limit to the size of the development? Does the limit represent the optimum size of the development? Other choices must be made with regards to plant and steamfield design. The development model is used to examine questions about the number and timing of wells, and plant conversion efficiency.

In order to investigate these questions, calculations were made with the development model employing different scenarios of development. For each scenario, one or two features of the development model were varied in order to examine the effect on the economic performance of the development. Sometimes the features that were varied corresponded to choices in development, such as in the conversion efficiency of the plant, while other times the features which were varied corresponded to one of the constraints in development. The generation level is varied for each scenario since, as will be shown, this can have a strong influence on the economics of the development. The following items review the features built into the development model and outline the ones changed for the different scenarios.

- 1) Generation Level. At what level of generation is the plant to operate? Since generation level determines fuel requirements, it can have a major impact on the cost per kWh of power generation, due to the effects of reservoir productivity. The choice of generation level on development cost is investigated here.

- 2) Project Lifetime and Discount Rate. Most of the field studies reviewed had 20 to 30 years as a project lifetime. Twenty-five years was used in this report. The discount rate used in this study was 10%.

- 3) Reservoir Pressure Behavior. It is embodied in the selection of the three Hurst constants. Only reservoir drawdown is determined in the Hurst **water** influx model; no energy considerations are included. For this study, the two sets of match parameters from the Wairakei match and the Ahuachapan match **are** used to represent possible cases of reservoir drawdown behavior. Note that the match parameters only dictate reservoir drawdown behavior. The **reservoir** inflow performance must still be specified to complete the reservoir behavior description. Thus, using the Hurst match parameters does not mean that the development model reservoir will behave exactly like the one it is **matched** with, unless, the inflow performance from that same reservoir is used.

- 4) Reservoir Inflow Performance. The same reservoir inflow **performance** curve, based on data from the Roosevelt Hot Springs measurement, was **used** in all cases. As previously mentioned, reservoirs with more productive! inflow performance are known, but the total field deliverability of the **development** model is comparable to fields around the world (Chapter 10).

- 5) Well Performance. Two different well performance curves were constructed. Only one of them, for the case of 9 5/8 inch casing, was used. **Due** to the inflow performance curve used here, there was little difference between the productivity of the 9 5/8 inch and 13 3/8 inch well. In a more productive reservoir, this choice could play a significant role, which could still be explored in the fashion shown here. The well performance curve used in **this** study assumed a surface pressure of 0.69 MPa, a depth of fluid entry of 900 hneters, a fluid enthalpy of 1100 kJ/kg and a casing diameter of 9 5/8 inches.

- 6) Conversion Efficiency. Part of conversion efficiency is the fraction of total production which is utilized in the plant. In the case of single flash plants, assumed here, steam coming from the separator is the only useful Stream. Since fluid enthalpy is fixed at 1100 kJ/kg and the separator pressure is fixed at 0.69 MPa (100 psia), the steam quality in the separator will be about 0.22 kg-steam/kg-total. Thus, 22% of the mass rate from the wells became the steam rate into the plant. For these conditions, the specific work of the fluid can be estimated for the case of a condenser plant and a backpressure plant. The plants were assigned an 8 tonne/hr-MWe conversion efficiency if there was a condenser, as is assumed for the central plant and condenser wellhead plant, and 15 tonne/hr-MWe conversion efficiency for a backpressure wellhead plant.
- 7) Initial and Annual Costs for the Plant and Steamfield. Development costs were seen to vary from project to project. There is no one set of costs representative of all projects. In this work, a cost scenario based on the observed cost ranges presented in Table K, but favoring the wellhead plants, was adopted. This was done because the adoption of "true" costs, representative of all projects, is impossible. It also exaggerated the contrast between the two types of plants, especially in light of the effects of reservoir productivity. The cost figures used in the development model are presented in the following section on results.

8.1 Development Model Computer Program

Computer programs were written which incorporated the different physical and economic features of geothermal development outlined in previous sections. Since field development for wellhead and central plants is treated differently, two similar computer programs were written.

The program "NPV.central" was written to calculate the net present value of a

geothermal project which incorporated a central plant. The program "NPV.wellhead" was written to calculate the net present value of a geothermal project which incorporates wellhead plants. They differ only as follows. For NPV.central, at the start of the project a plant is built and wells are drilled to meet the required generation level. Then, as field productivity declines, new wells are drilled to supply the requisite fuel to the central plant. In NPV.wellhead, at the start of the project wellhead plants and wells are installed in pairs to meet the required generation level. As field productivity declines, new wellhead plant and well pairs are added to maintain the required generation level.

This difference only influences the calculation of the net present value of development cost. Otherwise, the programs are the same. Figure 26 is a block diagram of the two computer programs. Appendix C contains the computer programs, an input file and part of an output file. Both input and output use free-format and are directed to the standard devices. The output files are extensive and contain the values of almost all the variables and parameters for each of the times steps at each of the required generation levels.

9. RESULTS AND DISCUSSION

Figure 27 is a graph demonstrating the general form of the results. Before considering the assumptions which went into calculating this figure, note the nature of the curve. Two points, A and B, have been identified. Point A corresponds to the 50 MWe generation level and B corresponds to the 150 MWe generation level. At 50 MWe the net present value of the development cost is 100 \$M while at 150 MWe the cost is 447 \$M. Plant and steamfield costs used in calculating the net present value were given in Chapter 7.

Slopes on this graph correspond to different costs of generation per kWh. To calculate the cost per kWh, the net present value of the development cost is levelized throughout the life of the project. That is, the net present value must be converted into a series of equal payments over the economic life of the project. If the present value factors for each year of the life of the project, at a specified discount rate, are summed together and then divided into the net present value of development cost, this yields the equivalent annual levelized development cost of the project. The sum of the present value factors at a 10% discount rate for 25 years is 9.08.

$$9.08 = \frac{1}{(1 + 0.1)^1} + \frac{1}{(1 + 0.1)^2} + \frac{1}{(1 + 0.1)^3} + \dots + \frac{1}{(1 + 0.1)^{25}}$$

Then, the cost must be converted from millions of dollars to mills. Dividing by the generation level, converted from MWe to kWe, and the number of annual hours times the plant capacity factor completes the calculation. For example, at point A the average cost of generation per kWh is:

$$\frac{100 \text{ } (\$M) \times 10^9 \left(\frac{\text{mills}}{\$M} \right)}{9.08 \times 50 \text{ } (MWe) \times 10^3 \left(\frac{kWe}{MWe} \right) \times 8760 \left(\frac{\text{hours}}{\text{year}} \right) \times 0.8 \text{ } (\text{capacity factor})} = 31.4 \left(\frac{\text{mills}}{\text{kWh}} \right)$$

A distinction is drawn between the *average* cost of power generation and the *marginal* cost of power generation. The average cost is found from the slope of the line connecting some point on the graph with the origin. It represents the average cost of all the power generated, both the first MWe and the last. The marginal cost is found from the slope of the tangent to the cost curve at some point along the curve. It represents the cost of the next (or last) increment of power generation. At point A both the marginal and average cost are the same, since the curve is relatively straight and passes through the origin. However, at point B the average cost equals 47 (mills/kWh) and the marginal cost equals 83 (mills/kWh). Therefore, it is very expensive to increase the generation level at 150 MWe. If the plant size were to be increased from 150 to 151 MWe, the cost of the additional 1 MWe of power would be 83 mills/kWh.

Suppose that there is only one alternative technology for baseload power generation. Further suppose that it could generate power over that same 25 year period for 47 mills/kWh. This represents a constraint imposed on geothermal power generation, since the other technology becomes attractive if geothermal generation becomes more costly than it. Point C (about 90 MWe) is the point on the cost curve where the marginal cost of geothermal power generation is 47 mills/kWh. Each additional MWe of power generation developed from the geothermal resource above Point C will cost more than 47 mills/kWh.

Assume that the objective for meeting baseload generation needs is to supply the baseload demand at the minimum cost. The optimal development of baseload generation capabilities would be to develop the geothermal field to 90 MWe (Point C) and add baseload generation above that from the alternative technology. If another geothermal project exists, then the optimal development of baseload generation would mean developing both of the geothermal projects until the marginal rate of power generation was equal to the alternative. In general, the optimal strategy for

generating the power is achieved when the marginal cost of generation is the same for all the utilized technologies.

Why does the marginal cost of geothermal generation increase with generation level? That is to say, why does the development not demonstrate economy of scale instead of dis-economy of scale? Plant costs were linear with respect to generation level so there should be no dis-economy of scale due to this component. However, steamfield development cost is creating a dis-economy of scale because the number of wells per MWe is not the same at each generation level. This is due to the increased effect of declining reservoir productivity with increasing generation level.

Figure 28 shows the total number of wells required to supply the geothermal fluid at the indicated generation level for the same scenario as Figure 27. Eleven wells are required at the 50 MWe level, yet 78 wells are required at the 150 MWe level. While the generation level tripled, the required number of wells increase about seven times.

At greater levels of generation, the increased production requirements makes the reservoir drawdown more severe. Consequently, the productivity decrease becomes more severe. The costs of steamfield development imposed by the declining productivity create a dis-economy of scale for a geothermal development. It is depended upon not only the total energy requirements of the generation level but also upon the rate requirements for production from the reservoir. Even if the plant costs exhibited some economy of scale, eventually, the reservoir effect would overshadow these.

As mentioned before, Figure 27 required many conditions be set upon the nature of the reservoir, well, and plant. This "scenario" of development included the following. The reservoir drawdown was determined from the Hurst model using the match parameters from the history match of the Ahuachapan reservoir. The cost figures for this scenario, and all subsequent ones was chosen specifically to favor

the wellhead units. The actual values are given in Section 7.4. As mentioned before, this was done to exaggerate the difference between the two types of plants as much as possible.

9.1 Effect of Reservoir

The reservoir description is composed of the parameters used by the Hurst model to forecast drawdown and the reservoir inflow performance curve. In the following, only the drawdown parameters are varied, the reservoir performance curves are the same. The drawdown match parameters are from the match of the Ahuachapan data and the Wairakei data. In effect, there are two reservoirs with different drawdown responses to production, but with the same reservoir inflow performance. Although each reservoir will allow equal fluid flow to the well for a given ΔP_{res} , one reservoir will drawdown faster than the other. By comparing the results from the development model for these two cases, the effect of the reservoir drawdown on the development cost can be explored. In one case, the Ahuachapan drawdown parameters are used and, in the other, the the Wairakei drawdown parameters are used.

Figure 29 presents the cost vs. generation level for two scenarios. Both have the same assumptions of reservoir inflow Performance, well performance, separator pressure and plant conversion efficiency. The results for the scenario employing the Wairakei drawdown parameters could be looked at as characteristic of a large reservoir with a highly compressible nature that tends to maintain its pressure and productivity with time. The Ahuachapan scenario could be characteristic of a small reservoir, also highly compressive, which would exhibit greater decline in pressure and productivity with time.

Figure 29 indicates that there is a great cost advantage in having a large reservoir over a small reservoir. The small reservoir is more costly to develop than the larger reservoir at all generation levels. This difference becomes more

pronounced with increasing generation level. This is due to the greater decline in productivity which would occur with the smaller reservoir. At lower generation levels, both reservoirs can supply the required geothermal fluid with little drawdown over the life of the reservoir. However, at the higher generation level the required fluid flow rates become large enough to greatly decrease the productivity of the smaller reservoir over the twenty-five year period, requiring additional wells and plants to make up for the decline in productivity. By the 150 MWe generation level, the Ahuachapan scenario has a marginal cost of 83 mills/kWh while the Wairakei scenario has a marginal cost of 40 mills/kWh.

At low generation levels, the marginal cost of generation can be calculated from the cost data once the productivity of a well is known. This is because production requirements are small and the change of well productivity over the life of the project is small. This means that the initial plant and field development is likely to suffice for the life of the project since declining productivity will not require the addition of plant capacity or extra wells. For both of the reservoir scenarios, the initial fluid production was about 220 tonne/hr per well. With separator quality of about 22% this equals 48 tonne-steam/hr. The conversion efficiency of the wellhead plants is 8 tonne/hr-MWe so each well was about a 6 MWe well. Over the 25 year life of the project the wells productivity never drops below the 5 MWe level so new wells and wellhead units are not required. As is discussed in Chapter 10, production at about 5 MWe per well is typical for geothermal developments.

At the ten MWe generation level, it takes two wells to generate the required electricity. The development cost is then the initial investment cost of two wells and two wellhead condenser plants plus their annual costs discounted for a twenty five period. This comes to \$20.3 million. For a 20 MWe plant the productivity also never drops below 5 MWe per well and the cost of the development comes to \$40.6 million. The marginal cost is the same at both points, about 32 mills/kWh, and constant in

between.

Both of these scenarios have the same cost of development in the first years of the project, regardless of generation level. However, as time progresses, the effect of declining productivity is more severely felt with higher generation levels and smaller reservoirs. By plotting the fraction of total cost incurred in the first year of the project, the costly effect of declining productivity can be observed. Figure 30 plots this cost fraction versus the generation level for the two scenarios described above. These curves are not continuous due to the discrete nature of the wells and plants; wells only come one at a time therefore the costs come in lump sums too. At lower generation levels the initial development is satisfactory for the life of the project. At a 150 MWe generation level the initial cost fraction of the total for the Ahuachapan scenario is about 0.55. Thus, at 150 MWe the development which follows the first year of the project nearly equals the cost of the development in the first year, and that is after discounting and without the effects of inflation.

9.2 Effect of Plant Choice

While it is nice to have the choice of developing large reservoirs over small reservoirs, this is not always a possibility. Choices in plant and well design are more often possible. In the next four scenarios, the contrast between a central plant and a wellhead condenser plant is investigated, first for a small reservoir and then for a large.

Two of these four scenarios are presented in Figure 31. In this figure the cost of development is compared between central plants and wellhead condenser plants using the Ahuachapan drawdown parameters. As mentioned before, the cost of plant development was purposely chosen to favor the wellhead plants. This is reflected in the fact that the cost for the central plant scenario starts out a little higher than for the wellhead plants. At low generation levels the marginal cost of development is greater for the central plant scenario, too. The situation changes as the generation

level increases. At about 70 MWe the marginal cost of two the Scenarios is equal. As the generation level increases still further, the marginal cost of the condenser wellhead plant scenario is now greater than that of the central plant scenario. At 120 MWe the cost of the two scenarios is equivalent and, at greater generation levels than 120 MWe, the cost of the condenser wellhead scenario has become greater than that of the central plant. For these two scenarios the optimal choice depends not only upon the type of plant but also on the intended level of generation.

What created this switch in the optimal plant selection? At low generation levels the favorable assumption of plant costs gave the edge to the wellhead plants. Yet at higher generation levels this advantage was overcome by a more costly factor, namely the declining reservoir penalty. But, the reservoir properties and plant conversion efficiencies were the same for both scenarios. Why should the same decline in productivity have more of an effect on the wellhead scenario? This comes about due to the constraint of having each wellhead unit hooked up to just one well. At higher generation levels the wells productivity declines severely. Each of the wellhead units is generating much less than it is capable of generating. There is over-installed capacity in the wellhead scenario at high generation levels. However, the central plant scenario always has the plant capacity exactly as required by the generation level since wells can be connected to the plant as required. Thus, it is seen that maintaining generation near the level of installed capacity greatly influences the development cost.

Suppose that, instead of using the Ahuachapan drawdown parameters, as is done for the two scenarios above, the Wairakei drawdown parameters are used to contrast development using central plants with development using condenser wellhead plants. The cost of development for these two scenarios is shown in Figure 32. Once again, at low generation levels the optimum selection is dominated by the Cost assumptions chosen to favor the wellhead plant scenario. But, unlike the

previous scenarios, the optimum does not switch to the central plant scenario at higher generation levels. In this case, the well productivity does not decline enough to create a change in the optimum. This demonstrates how the *reservoir* properties can have an effect on the optimum *plant* choices.

9.3 Effect of Conversion Efficiency

The cost assumptions used above are more favorable to the wellhead plants than they are to the central plants. But the cheapest form of plant is not always the best form of plant, even at low generation levels. Figure 33 contrasts the cost of development for two forms of wellhead plant. One scenario is for a wellhead plant with a condenser and the other scenario is for a back-pressure wellhead plant. The major difference between the two, besides the cost differences, is the improved conversion efficiency brought about by the use of the condenser. As shown in the figure, although the plant costs favor the backpressure units, the cost of development with them is greater at all generation levels.

Under different conditions of well productivity, the back-pressure plant could be a better choice. If the well productivity were great enough, than one well might be able to supply enough steam to meet low generation level requirements, regardless of the form of wellhead unit used. However, as soon as the steamfield development for back-pressure wellhead units starts to significantly outstrip the steamfield development for condenser units, then the condenser units become the more economic alternative. The generation level at which this occurs depends upon the trade-off between the cost of improving the conversion efficiency versus the benefits of reducing the total steam rate, and thereby reducing the field development costs.

9.4 Effect of Constant Rate Production

In this study, the well productivity was such that the the initial production from

one well could be utilized by a 5 MWe wellhead unit. In addition, the decline in productivity was never enough to make the wells produce below the minimum operating flow rate for the wellhead units. Thus, the wells were allowed to flow at whatever rate they would give up to the fixed separator pressure.

Another possible operating method would be to fix the mass rate from the wells by varying a choke size. The fixed flow rate which can be maintained by the wells for the life of the project can be determined. First, drawdown in the reservoir at the end of the project life is determined. Then, the reservoir inflow performance curve at the lowest reservoir pressure and the well performance curve will intersect at the **flowrate** which can be supported by the well for the life of the project. At the end of the life of the project the choke will be completely open and the well will be producing to the fixed surface pressure maintained in the separator. Note that the well performance curves only apply to the end of the project life, when separator pressure is equal to the value assumed in constructing the well performance curve.

Figure 34 contrasts the development costs for two different scenarios of production from the wells. In one the wells are choked to produce at a **constant** rate while in the other the wells are free to flow to a regulated surface pressure. In this case, the Ahuachapan drawdown parameters were used. At low generation levels the two scenarios have the same development costs. But as the generation level increases the development cost of the constant rate scenario increases above that of the constant pressure scenario. This is due to the increased field development required to maintain the fix rate wells. By choking the wells, they are not utilized to the full limits of their potential, requiring more wells to supply the steam at the start of the project. Figure 35 indicates that this effect is much smaller if the Wairakei drawdown parameters are used instead. Nonetheless, fixed rate wells add cost because they are drilled up front, when higher productivity could provide the required flow from fewer wells.

9.5 General Applicability of Results

Tester' stresses the site-specific nature of geothermal development. The wide range of development costs drawn from field studies for this work underscored this fact. Consequently, the magnitude of development costs in the results cannot apply in all situations, since such costs are regionally and resource dependent. However, the potential change in productivity is common to all geothermal development. Its economic effect has been seen to depend on generation (production) level, plant conversion efficiency, and type of plant. This economic effect has been shown to be significant. The general trends of the results should apply to all geothermal developments.

The interdependent nature of reservoir, well and plant must be considered in order to plan the best development. The development model presented here is general enough to accomplish this for any form of liquid-dominated development. However, different techniques for calculating productivity, plant efficiency or economic criterion could be substituted. But the elements of the development model must be considered in order to properly plan the development.

10. UNCERTAINTY IN GEOTHERMAL DEVELOPMENT

Geothermal development is characterized by complex and uncertain decisions concerning the exploitation of an energy source. Uncertainties arise because major factors of the development are unknown, or inexactly characterized. When decisions are made, and the outcome of the decision depends upon the nature of these uncertain factors, there is a risk that the outcome will be extremely **undesirable**.

Barr and **Grant**⁴¹ presented an overview of the uncertainties which are encountered in geothermal development. They cite plant oversizing as the major economic risk in geothermal development. As has been shown in this study, field deliverability with time is the dominant factor in determining the economic size of geothermal liquid dominated development.

Previous discussion in this work on sizing the plant has concentrated on economic and physical limits. However, the uncertain outcome in the field productivity with time imposes another constraint upon the decision of sizing the plant. In order to deal with the new uncertainty constraint, the decision process and outcomes must be characterized.

Decision analysis provides a framework for analyzing the decision process. Harbaugh, **Doveton** and **Davis**⁴⁰ discuss methods for quantifying the uncertainty in oil exploration and techniques of decision analysis. Decision analysis requires three elements in order to be performed. First, the uncertain features must be identified and some probabilistic estimate of their outcomes must be made. **Second**, the decisions made before, and in response to, the uncertain outcomes must be identified. The sequence of decisions constitutes a strategy for **coping** with the uncertainty. Third, a criterion for judging the effect of the outcomes must be provided.

10.1 Characterizing the Uncertainty in Field Deliverability Outcome

The uncertainty to be addressed here is in the long term deliverability behavior of the geothermal field. One approach to characterizing this uncertainty would be to take the three elements of field deliverability - reservoir drawdown with time, reservoir inflow performance and well performance - and treat each of **these** as a separate uncertain component of the productivity. However, the data is not available to quantify the probability of outcomes for these three factors. Another approach would be to simply estimate the possible outcomes, based on previous experience. However, for the sake of consistency, it is good to rely on measurable quantities to determine the possibilities and probabilities of outcomes.

A measurable characteristic of field deliverability is required. Such a characteristic may be found from the *observed* outcomes for geothermal liquid dominated developments already in existence or attempted. Barr and Grant⁴¹ suggest such a characteristic. They compare the performance of fields by taking the cumulative output from the field, measured in terms of **MWe**, and dividing it by the total number of wells drilled. The effects of declining deliverability with time, and success rate in drilling with time, can be examined by observing this deliverability ratio for a field over time.

The deliverability ratio was calculated for fields from around the world. This ratio was an average and did not consider variations of the ratio with time. Data was supplied by Barr and Grant⁴¹ and the responses to the Geothermal Country Update for the International Symposium on Geothermal Energy in Hawaii, August 26-30, 1985. Data was supplied for geothermal developments in Turkey, Japan, Iceland, The Philippines, Costa Rica and New Zealand. Table 12 presents the deliverability ratios drawn from the above sources.

The **MWe** column in Table 12 was not provided directly from the country update data. However, the flow rate and enthalpy of the fluid for each well was provided.

The **MWe** was estimated by assuming a steam quality and conversion efficiency. This resulted in a ten percent conversion of the thermal MW of a well into electric **MWe**. The fields included in Table 12 mainly represent existing or attempted sites of electricity generation from geothermal sources.

Figure 36 is a histogram of the data from Table 12. For reasons pointed out below, the Japanese fields were excluded from this histogram. This histogram could be used to provide probabilities for the reservoir productivity **outcomes** when developing geothermal fields. This data represents a straightforward way of characterizing the field deliverability. However, there are some disadvantages in its use. What is really desired is the probabilities of different outcomes, *conditional* on a field having been deemed attractive enough to develop. The need is to quantify the risk of oversizing the plant, given that some standard set of criterion have been employed to certify the field's potential. These exploration criterion are numerous and include items like discharge testing, chemical analysis and **resistivity** surveys. Furthermore, the development drilling of the fields should also have been conducted in consistent fashion.

It is unlikely that such a set of criterion has been consistently applied to the data set for Table 12. The Japanese data strongly suggests some bias in overdrilling their geothermal fields. Table 13 presents the same data as in Table 12, sorted in order of deliverability ratio. The consistent occurrence of the Japanese fields at the bottom of this sorting is probably indicative of overdrilling, rather than exceptionally unproductive reservoirs. Assuming that to be the case, they were excluded from the histogram.

Most of the fields presented in the data are developed geothermal generation projects. However, some are notable failures. An arbitrary distinction between these two has been made for fields producing about 1 **MWe** per well on **average** and those producing greater than 1 **MWe** per well. About 20% of the fields fall into the former

category and the remainder fall into the latter. On average, the top 80% have a productivity ratio of about 5 MWe per well. Thus, these developments have steamfields which are about 5 times more productive, either by virtue of resource characteristics or prudent drilling practices.

While it is possible to assume a continuous probability distribution corresponding to Figure 36, it is felt that the data does not warrant this. Similarly, given the successful nature of developments with deliverability ratios around three, it is reasonable to group the top 80% into one general category of as planned field deliverability outcomes, averaging about 5 MWe per well, with another unfavorable field deliverability outcome, averaging about 1 MWe per well.

10.2 Evaluating Uncertain Strategies

In order to cope with the uncertainty of development there are two alternatives. One of these is to distribute the risk among several parties until an acceptable level of risk is undertaken by each party. This was discussed with regards to the ownership of geothermal projects. This strategy for dealing with the risk adds cost to the development because of risk premiums. However, this strategy does not change the uncertainties of the development. Another strategy for dealing with the risk is to reduce the uncertainties, and therefore the risks of the development. This strategy calls for acquiring additional information about the development at some cost.

What techniques are available to gain information about the productivity behavior of the reservoir over time? One technique is to engage in simulation (numerical modeling) of the reservoir behavior. The costs of this strategy would be for facilities and staff to conduct the simulation and, perhaps, additional wells and field tests to gather data to support the simulation exercise. This technique is employed extensively in the oil industry. It has the advantages of being fast and cheaper than alternatives discussed below. However, it may not always be

technically feasible. Another possibility would be direct measurement of the uncertain features of the development. It is this strategy which is examined here.

Direct measurement of uncertain reservoir productivity is a lengthy and costly strategy. It involves production of the reservoir for a long enough period of time to forecast productivity. History matching with the Hurst water influx model indicated this would take about six years. The direct measurement of field properties is made by staging the development. The first stage of the geothermal development is sized much lower than the estimation of resource limits. This technique offers the advantage of conclusively reducing the uncertainty not only in reservoir productivity, but also in other important and uncertain resource traits such as chemical composition and temperature.

For the purpose of discussion here, the decision process can than be simplified to the choice between two possibilities. One is to build the plant at the economic limit suggested from an uncertain analysis. In this case, the risk is fully assumed. The second strategy is to stage the development by first constructing a pilot plant, waiting until the uncertain outcomes have been observed, and then proceeding with full scale development (if warranted).

Finally, a criterion is required to evaluate the results of the different outcomes. The cost of power generation provides one possible economic criterion. This criterion was used earlier in the study to define the economic limit to reservoir development, when uncertainty was not considered. As before, it provides a method for comparing the different geothermal development strategies and alternative form\$ of baseload generation.

10.3 Example of Uncertainty in Geothermal Development

Assume that the initial estimates for the reservoir indicate that it Should be able to support a 100 MWe power station. A twenty-five MWe power plant is proposed

for the first stage of development. The initial development choice is whether to immediately construct the 100 MWe power station and take a chance on the outcome of reservoir productivity, or, to initially build a 25 MWe stage in development and wait 6 years to determine the outcome of reservoir productivity.

Results from the development model indicated that none of the scenarios showed much effect due to declining reservoir productivity at the 25 MWe generation level, however, some did show significant increase in the cost of power generation at the 100 MWe level. Then, the favorable outcome, with 80% probability, is that the geothermal reservoir will be able to support the production requirements of the 100 MWe station for 25 years. The unfavorable outcome, with 20% probability, is that the resource will only be able to support 25 MWe for 25 years. The outcomes are the same for each decision.

Suppose the 100 MWe power plant is built. If the favorable outcome occurs than the cost of power generation would be exactly as predicted from the initial economic analysis. However, if the unfavorable outcome occurs, then the plant is oversized. Assume that overproduction from the field has created severe declines in productivity and rendered it unsuitable for any further power generation. The plant would be shut down and the 100 MWe of power would be generated from an alternative source. The alternative source in this study will be represented by an existing thermal plant. Thus, the cost of the power which was generated for the first 6 years will escalate, since the project life was not the 25 years originally planned. Instead, of being levelized over a twenty-five year period, the development costs would be levelized over a six year period. Assuming no resale value for the plant, the cost of power generation for the first six years of operation would be the estimated cost per kWh times the ratio of the 25 year levelization factor over the 6 year levelization factor, or 9.08 over 4.36. The estimated cost per kWh was determined by spreading the net present value of all development costs over a twenty-five year

economic lifetime. Since the project life has been shortened by the unfavorable outcome in field deliverability, the estimated cost of power will have to be levelized only over a six year period instead. Thus, multiplying by the 25 year levelization factor originally used to obtain the cost of power estimate, and dividing by the new 6 year levelization factor, yields the new estimated cost of power. As expected, it is much higher than before, since a large plant and field have been developed to supply power for only a short period of time.

Suppose that the staged 25 MWe development is chosen, instead. After six years, the reservoir productivity with time is known. Assume that at that time the development will be upgraded to the 100 MWe level in the event of a favorable reservoir outcome. In this case, for the first six years of generation, 25 MWe was being produced by the geothermal plant and 75 MWe was being generated from the alternative thermal source. At the six year point, if the favorable outcome occurs, the plant can be upgraded to the 100 MWe level. However, the additional 75 MWe of power generation from the geothermal source should not be assigned the same cost as the original 25 MWe from the geothermal source. The cost of this portion of the power should be escalated by the ratio of the 25 year levelization factor to the 19 year levelization factor. Put another way, there must be some penalty for delaying the full scale construction of the plant when the resource warrants full scale development. Since the goal is to generate 100 MWe of power for a twenty-five year period, having the full scale plant in effect for only 19 years means that the development costs of the additional 75 MWe should be spread over only the nineteen years remaining in the project life. An additional penalty is that for the first six years there was utilization of the more expensive thermal alternative to make up the 100 MWe of power generation. If the unfavorable outcome occurs, then the pilot 25 MWe plant is not upgraded and the thermal source is utilized to make up the remaining 75 MWe of baseload power.

Figure 37 is a decision tree of the example outlined above. Square nodes represent decisions and circular nodes represent uncertain events. At the end of the last branches are estimates for the total cost of 100 MWe of baseload power generation over the 25 year lifetime of the project. In order to calculate these total costs, values for the cost of geothermal power generation and a thermal alternative were needed. Ringer⁴² presents data on the cost of electricity production for several technologies. Included in the data are figures for steam geothermal power production and conventional coal power generation. Using these figures for the cost of power generation in cents per kWh, the total cost of 100 MWe of generation for twenty five years can be estimated as outlined above for the four possible decision paths of Figure 37. Appendix D gives the calculation of total cost appearing at the ends of the branches.

The decision tree allows the best strategy for dealing with the uncertainty to be evaluated. First, the expected value of each node is calculated. To do this, the total cost estimates of each branch are multiplied by the probability of their occurrence and then summed for each probability node. Then, the decision which leads to the node with the highest expected value is selected. The expectation is that, in the long run the decision maker will reap the maximum reward from decisions by playing the odds. Decision science also provides other criterion for selecting decisions, other than expected value, which are not discussed here. These techniques attempt to quantify the decision makers attitude towards risk.

In the current example, the expected value of the node following the decision to build the 100 MWe plant is 465 million dollars and the expected value of the node following the decision to build the 25 MWe pilot plant is 478 million dollars. Thus, the expected value decision is to forego the staged development and to construct a full scale plant immediately.

This result is, perhaps, surprising in light of references^{4,7,9,41} in the literature on

the benefits of staging development. Most studies adopt a viewpoint of revenue or profit maximization as an economic criterion. However, this example used cost minimization for baseload power production as an economic criterion. Thus, the certain delay in full scale power production arising from staged development, and the use of expensive thermal generation that the delay entailed, overshadowed the cost of the probability of the unfavorable reservoir outcome. Note also that the expected value of the two nodes are very close. Thus, a small change in the probabilities or estimated cost of power along any of the branches could change the result. The important fact is that the tree demonstrates the crucial trade-off between delay in full scale development and the risk of oversizing the development. The path selected depends upon how the probability and cost of the outcomes are calculated.

This example presents a narrow view of the possible decisions of development. For example, even if the favorable outcome occurs after building the 25 MWe pilot plant, the decision to upgrade to 100 MWe might still depend upon factors such as the price of alternative generation or construction costs six years hence. Another change would be to introduce the uncertainty in the cost of the thermal alternative. In short, decision trees are unique to each development situation. The relevant decision process changes from one project to the next.

Decisions made before the field development commences have also not been included in this work. Exploration strategy is just as important to the overall development of the project. Limitations imposed by financing would play an important role in early project development strategy.

11. CONCLUSIONS

- 1) Lumped parameter, water-influx modeling has been used to match and forecast the drawdown-production data from several geothermal fields. Match results indicate that in the small reservoir of Ahuachapan, El Salvador, two-phase compressibility effects exist, while in the much larger reservoir of Wairakei, New Zealand, free-surface, liquid compressibility exists.
- 2) A development model has been presented which integrates reservoir, well and plant characteristics along with an economic criterion for evaluating the cost and benefit trade-offs between them.
- 3) Results from the development model indicate that the cost of development was most sensitive to the productivity of the steamfield, given assumed values for plant and steamfield costs. Steamfield productivity directly influences steamfield development cost, which comprises a large fraction of the cost of power production. The costs imposed by declining productivity become more severe with increasing production rates and smaller reservoirs. These effects should be considered when comparing different strategies for plant and steamfield.
- 4) If the effects of declining productivity become severe enough, then wellhead generation becomes more costly than central plant generation, due to unused generation capability. This assumes that the wellhead unit is supplied steam from a limited (one) number of wells. Thus, at low generation levels, with little change in productivity, wellhead units could be the economic alternative. But, at higher generation levels and declines in productivity, wellhead units could be less attractive than central plants. This presents a dilemma if wellhead units are to be used to prove a field at low generation levels. If the field turns out to be productive over a long period of time, then the wellhead units will continue to be economic at higher generation levels. However, if the field productivity

decline is severe enough, a central plant may be preferable at higher generation levels.

- 5) Successful geothermal developments seem to require about 5 MWe per well productivity, averaged over the life of the project. Due to the uncertain nature of early information on geothermal resources, some attempted developments do not approach this productivity level. Staging development is one technique for improving the certainty of the resource information. Nonetheless, if the power is required to meet baseload demand, then the higher cost of alternative baseload power may warrant assumption of the risk of oversized development, in order to provide the lowest cost baseload generation.

12. RECOMMENDATIONS

The economic effects of declining field productivity have been discussed in this report. Inclusion of energy balance in the lumped parameter model would improve the modeling of resource effects on the economic performance of the development. Castanier, Sanyal and Brigham³⁷ present a lumped parameter model incorporating energy effects.

The development model presented here could be used to investigate different well designs. Only one well design is considered in this report since the assumed reservoir performance minimized the effect of this choice upon field productivity. In more productive reservoirs, well design can have a significant impact on field productivity, as was briefly discussed.

The minimization of development cost and baseload power generation cost were the economic criteria used in this study. Adopting profit or revenue maximization as criteria creates a different perspective on geothermal development. The choice of economic perspective on optimum development strategy could be investigated.

REFERENCES

1. Tester, J.: "Energy Conversion and Economic Issues for Geothermal Energy," *Handbook of Geothermal Energy*, Edwards, LM, Chilingar, GV, Rieke III, HH, and Fertl, WH (eds.) Gulf Publishing Company, Houston, Texas, (1982) 471-688.
2. Fuji Electric Co., Ltd. "FUJI Packaged Type Geothermal Power Generating Unit", Brochure GEC 83-1 (1984).
3. Gudmundsson, J.S. and Bott, T.R.; "Deposition - the Geothermal Constraint" I. Chem. E. Symposium Series No. 48, (1977).
4. Southan, JAN, Wigley, DM, Carey, B.S., Constable, LK, Hall, NR, Mills, TP, and Sell, P.: "Report on Small Geothermal Power Development in New Zealand, Part 1, Ngawha - Mokai - Tauhara," New Zealand Ministry of Works and Development and Ministry of Energy, Auckland, New Zealand, December (1983).
6. Ramey, Jr, HJ, (ed): "Reservoir Engineering Assessment of Geothermal Systems," Department of Petroleum Engineering, Stanford university, October, 1981.
6. Butz, J. and Plooster, M.: "Final Report: Subsurface Investigations at the Rossevelt Hot Springs, Utah, KGRA," University of Denver Research Institute, Denver Research Institute Report, DOE/ET/28389-1, (1979).
7. Barr, H, Grant, MA and McLachlan, R.: "Proving and Development of Geothermal Fields - Risk, Strategy and Economics," Applied Mathematics Division, Dept. of Scientific and Industrial Research Wellington, New Zealand, (May, 1984).
8. Golabi, K, Scherer, C.R., Tsang, C.F. and Mozumder, S: "Optimal Energy Extraction from a Hot Water Geothermal Reservoir," Water Resources Research, Vol. 17 No. 1, 1-10 (February, 1981).
9. Grant, MA. and Barr, H: "Optimising Field Proving and Development," Stanford Geothermal Workshop, Stanford, California, U.S. (1985).
10. Olsen, G: "Depletion Modeling of Liquid Dominated Geothermal Reservoirs," MS Report, Stanford University, Stanford, California, (1984).
11. Love, RN. and Bolton, R.: "Wairakei Geothermal Power Project: New Zealand," *Geothermal Energy Projects - Planning and Management*, f1 Goodman, LJ. and Love, RN. (eds.), Pergamon Press, Elmsford, New York, (1980).
12. Stacey, R.E. and Thain, I.A.: "25 Years of Operation at Wairakei Geothermal Power Station" Proceedings of the 5th NZ Geothermal Workshop, The University of Auckland Geothermal Institute, Auckland, New Zealand, 79-90, (1983).

13. Vides J.R.: "Model Simulation of the Behavior of Ahuachapn Geothermal Field," Project report of the Geothermal Institute of the University of Auckland, Auckland, New Zealand, (1982).
14. Quintanilla, A.: "Computer Modelling of Ahuachapan Geothermal Field," Project report for the Geothermal Institute of the University of Auckland, Auckland, New Zealand, (1983).
15. Gudmundsson, J.S. and Olsen, G.: "Water Influx Modeling of Svartsengi Geothermal Field, Iceland", SPE paper 13615, Proceedings of the 55th Annual California Regional Meeting of the SPE, 265-274, (March, 1985).
16. Hurst, W.: "The Simplification of the Material Balance Formulas by the Laplace Transformation," Trans. AIME 213, 292-303, (1958).
17. Fradkin, L.J., Sorey, M.L., McNabb, A.: "On Identification and Validation of Some Geothermal Models," Water Resources Research, Vol. 17, No. 4, 929-936, (1981).
18. Fradkin, L.J.: "Identification of the Wairakei Geothermal System," Water Resources Research, Vol. 17, No. 4, pp. 921-927, 1981
19. Grant, M.A., Donaldson, I.G. and Bixley, P.F.: "Geothermal Reservoir Engineering," Academic Press (1982).
20. Gudmundsson, J.S.: "Discharge Analysis for Two-Phase Geothermal Wells," Transactions of the Geothermal Resources Council, Vol.8, 295-299, (1984).
21. Ryley, D.J.: "Analysis of the Flow in the Reservoir Well System," *Sourcebook on the Production of Electricity from Geothermal Energy*, J. Kestin (ed.), United States Department of Energy, Division of Geothermal Energy, (1980).
22. Dake, L.P.: "Fundamentals of Reservoir Engineering," Elsevier Scientific Publishing Company, New York, (1978).
23. Menzies, A.J., Gudmundsson, J.S., and Horne, R.N.: "Choked Flow in Fractured Geothermal Reservoirs," Proceedings of the 5th Annual New Zealand Geothermal Workshop, (1983).
24. Vogel, J.V.: "Inflow Performance Relationships for Solution-Gas Drive Reservoirs," Journal of Petroleum Technology, (January, 1968) 83.
25. Fetkovich, M.J.: "The isochronal Testing of Oil Wells," SPE paper 4529, (1973).
26. Brown, K.E.: "The Technology of Artificial Lift Methods," PennWell Publishing Company, Tulsa, Oklahoma, U.S., (1977).
27. Menzies, A.J.: "Flow Characteristics and Relative Permeability Functions for a Two-Phase Geothermal Reservoir from a One Dimensional Thermodynamic Model," Stanford Geothermal Program, Report SGP-TR-59, (1982).

28. Butz, JR.: "A Case Study of Two-Phase Flow at the Roosevelt Hot Springs, Utah KGRA," Geothermal Resources Council, Transactions Vol. 4,(September, 1980).
29. Kestin, J (ed.): "Sourcebook on the Production of Electricity from Geothermal Energy," Brown University, DOE/RA/4051-1, (March, 1980).
30. DiPippo, R, and Marcille, DF.: "Exergy Analysis of Geothermal Power Plants," Geothermal Resources Council, Transactions, Vol. 8,(August, 1984).
31. McHugh-Bodylski, J: "A Generic Overview of Geothermal Wellhead Generating Units," Geothermal Resources Council, Bulletin, (May 1985).
32. Hiriart, G.: "Comparacion Economica Entre Centrales Geotermicas Y PLantas a Contrapresion (Draft)," EPRI-CFE meeting, San Diego, (June, 1985).
33. Hiriart, G: personal communication, 1984.
34. Holt, B and Ghormley, EL: "Energy Conversion and Economics far Geothermal Power Generation at Heber, California; Valles Caldera, New Mexico; and Raft River, Idaho - Case Studies," EPRI ER-301 (Research Project 580), Topical Report 2,(November 1976).
35. Gibbs and Hill, Inc.: "A Comparison of Geothermal Wellhead Generiator Units to PGandE's Unit 21 Central Power Plant," report submitted to Paaific Gas and Electric Company and filed with the California Energy Commision, (1984).
36. VGK Consulting, Ltd.: "Hengill geothermal Power Plant Economical Screening Study," Report OS82023/JHD02, National Energy Authority, Reykjavik, Iceland (February, 1982) (in Icelandic).
- 37 Castanier, LM, Sanyal, SK. and Brigham, W.E.: "A Practical Analytical Model for Geothermal Reservoir Simulation," SPE California Regional Meeting, Los Angeles, California, U.S., SPE paper 8887,(April, 1980).
38. Moore III, WD: "Drilling Stabilizes at Sustainable Level with Broad Improvements Due in 1985,"Oil and Gas Journal, (October 1, 1984).
39. "U.S. Drilling Outlay Down 36.3% in 1983,"Oil and Gas Journal, (December 17, 1984).
40. Harbaugh, JW, Doveton, J.H., and Davis, J.C.: "Probability Methods in Oil Exploration," Wiley-Interscience Publication, John Wiley & Sons, New York, (1977).
41. Barr, H. and Grant, MA: "Coping with Uncertainty in Geothermal field Design," Sixth New Zealand Geothermal Workshop, Auckland, New Zealand (1984).
42. Ringer, M.: "Relative Cost of Electricity Production," Staff report for the California Energy Commission, Technology Assessments Project Office, P300-83-010, (December, 1983).

43. Reynolds, W.C.: "Thermodynamic Properties in SI," Department of Mechanical Engineering, Stanford University (1979).

Table 1	
Major Economic Factors Affecting Geothermal Development (after Tester')	
Resource Related	Depth to reservoir (geothermal gradient) Rock type and temperature Fluid composition Liquid-to-gas ratio Heat rejection conditions Water availability
Reservoir and Plant Engineering-related	Mass flow rate (well productivity) Thermal - pressure drawdown (lifetime) Conversion efficiency (mass rate per unit electric generation)
Financial Related	Drilling and plant capital costs Equity discount rate Debt interest rate Selling price of products (cents/kWh) Tax treatment and royalties

Table 2				
Calculation of Δp_{flow} and p_{wf}				
w (lbs/hr)	$P.I.$ (lb/hr-psi)	$\frac{w}{P.I.}$ psi	Δp_{flow} psi	p_{wf} psia
For 9 5/8 inch casing				
400,000	400	1000	330	430
500,000	545	917	413	513
600,000	725	828	502	602
For 13 3/8 inch casing				
500,000	435	1150	180	280
600,000	532	1128	202	302
750,000	690	1087	243	343
900,000	878	1025	305	405

Table 3	
Wairakei Reservoir Parameters	
parameter	value
r	2185 m
h	1000 m
β	0.2
k	$27 \times 10^{-15} \text{ m}^2$
μ	$120 \times 10^{-6} \text{ Pa-s}$
Q_a	1000 kg/m^3
ρ_r	800 kg/m^3
c_o	$2.4 \times 10^{-9} \text{ Po}^{-1}$
c_r	$8.4 \times 10^{-9} \text{ Po}^{-1}$

Table 4		
Wairakei Production Data		
year +	Reservoir Pressure (Bar.a)	Year's mass production (Million.tonne)
1953	61.5	5.5
1954	61.5	7.4
1955	61.5	10.7
1956	61.0	21.4
1957	61.0	20.0
1958	60.0	22.1
1959	58.6	37.34
1960	54.5	47.84
1961	52.8	42.25
1962	50.3	51.80
1963	46.9	73.4
1964	44.1	70.8
1965	42.8	65.8
1966	42.1	64.3
1967	41.4	59.6
1968	40.7	47.7
1969	39.9	55.8
1970	39.0	56.0
1971	38.5	54.3
1972	38.1	52.5
1973	37.8	48.2
1974	37.7	47.0
1975	37.5	46.1
1976	37.4	47.6
1977	37.2	46.5
1978	37.1	48.3
1979	37.0	45.85
1980	37.2	47.68
1981	37.5	46.98
1982	37.5	46.90

Table 5 Two Wairakei Matches				
	tc 1/day	σ	K MPa-s/kg	standard deviation
Match 1	0.003	0.450	8.03×10^{-4}	6.09
Match 2	0.008	0.185	6.71×10^{-4}	6.16

Table 6 Waisakei History Match Results				
	tc 1/day	σ	K MPa-s/kg	RESERVOIR COMPRESSIBILITY P_0^{-1}
3 year match	0.008	0.140	8.50×10^{-4}	3.43×10^{-8}
6 year match	0.008	0.220	6.47×10^{-4}	2.18×10^{-8}
12 year match	0.008	0.220	6.32×10^{-4}	2.18×10^{-8}
25 year match	0.008	0.185	6.71×10^{-4}	2.59×10^{-8}

Tebte 7	
Ahuochopon Reservoir Parameters	
parameter	value
r	1382 m
h	330 m
θ	0.21
k	$50 \times 10^{-15} \text{ m}^2$
μ	$120 \times 10^{-6} \text{ Pa-s}$
ρ_{θ}	850 kg/m^3
ρ_r	800 kg/m^3
c_{θ}	$2.3 \times 10^{-9} \text{ Pa}^{-1}$
c_r	$1.15 \times 10^{-8} \text{ Pa}^{-1}$

Table 8		
Ahuachapan Production Data		
year t	Mass Produced (kilotonnes)	drawdown (bar)
1968	825.8	0.0
1969	249.7	0.0
1970	3988.7	0.5
1971	3340.9	1.5
1972	7595.5	2.8
1973	2847.9	2.5
1974	3695.2	2.2
1975	6169.8	2.0
1976	12841.9	4.3
1977	18697.7	5.5
1978	18156.3	7.4
1979	18162.2	8.6
1980	17793.5	9.5
1981	22042.0	11.4
1982	17354.2	12.3

Table 9 Ahuachapan History Match Results				
	tc 1/day	σ	K MPa-s/kg	RESERVOIR COMPRESSIBILITY P_0^{-1}
3 year match	0.039	*	*	1.5×10^{-7}
7 year match	0.039	0.110	7.31×10^{-4}	4.2×10^{-8}
13 year match	0.039	0.035	1.08×10^{-3}	1.3×10^{-7}

• - limiting case where $\sigma \rightarrow 0$

Steamfield Costs: \$Million U.S. ~ 1984	
New Zealand Report, 10 cases	
Initial Steamfield Investment Cost per Production Well	tlin. 1.4 - Rex. 2.7 Avg. 2.2
Annual Steamfield Expense per Production Well	Min. 0.09 - Hex. 0.32 Avg. 0.18
EPRI Report, 9 cases	
Initial Steamfield Investment Cost per Production Well	Min. 1.6 - Max. 3.4 Avg. 2.7
Annual Steamfield Expense per Production Well	Min. 0.19 - Max. 0.33 Avg. 0.27

Table 11

Central Plant Costs, \$M U.S. 1984	
<p>Initial Investment Cost per MWe Installed</p>	<p>Min. 0.6 - Max. 1.4 Avg. 1.1</p>
<p>Annual Expense per MWe Installed</p>	<p>Min. 0.02 - Max. 0.03 Avg. 0.024</p>
<hr/>	
<p>Initial Investment Cost per MWe Installed</p>	<p>flin. 0.5 - flex. 2.8 Avg. 1.0</p>
<p>Annual Expense per MWe Installed</p>	<p>Min. 0.03 - Max. 0.11 Avg. 0.06</p>
<hr/>	
Back-Pressure Wellhead Plant Costs, \$M U.S. 1984	
<p>Initial Investment Cost per MWe Installed</p>	<p>flin. 0.5 - Max. 1.2 Avg. 0.7</p>
<p>Annual Expense per MWe Installed</p>	<p>Min. 0.015 - Max. 0.07 Avg. 0.035</p>

Table 12			
World Data on MWe/Well			
Field Name	MWe	total wells	MWe/Well
Costa.Rica	33	6	5.5
Iceland.Krafla	39	24	1.6
Iceland.Namafjall	9.6	3	3.2
Iceland.Nesjavellir	18	10	1.8
Iceland.Svartsengi	114	11	10.4
Japan.Hatchobaru	65	51	1.3
Japan.Mori	78	17	4.6
Japan.Kakkonda	161	45	3.6
Japan.Kirishima	21	14	1.5
Japan.Matsukawa	36	19	1.9
Japan.Onikobe	25	10	2.5
Japan.Onuma	13	11	1.2
Japan.Otake	30	34	0.9
Japan.Suginoi	10	4	2.5
NZ.Broadlands	260	45	5.8
NZ.Wairakei	360	120	3.0
NZ.Mokai	50	5	10.0
Philippines.Bacon.Manito	86	19	4.5
Philippines.Mak.Ban	350	83	4.2
Philippines.Palipinon	234	51	4.6
Philippines.Tiwi	480	90	5.3
Philippines.Tongonan	390	52	7.5
Turkey.Denizli	71	16	4.4
Turkey.rest	33	8	4.1
U.S.Baca	25	35	0.7

Table 13			
World Data on MWe/Well Sorted by MWe/well			
Field Name	MWe	total wells	MWe/Well
Iceland.Svartsengi	114	11	10.4
NZ.Mokai	50	5	10
Philippines.Tongonan	390	52	7.5
NZ.Broadlands	260	45	5.8
Costa.Rica	33	6	5.5
Philippines.Tiwi	480	90	5.3
Japan.Mori	78	17	4.6
Philippines.Palipinon	234	51	4.6
Philippines.Bacon.Manito	86	19	4.5
Turkey.Denizli	71	16	4.4
Philippines.Mak.Ban	350	83	4.2
Turkey.rest	33	8	4.1
Japan.Kakkonda	161	45	3.6
Iceland.Namafjall	9.6	3	3.2
NZ.Wairakei	360	120	3
Japan.Onikobe	25	10	2.5
Japan.Suginoi	10	4	2.5
Japan.Matsukawa	36	19	1.9
Iceland.Nesjavellir	18	10	1.8
Iceland.Krafla	39	24	1.6
Japan.Kirishima	21	14	1.5
Japan.Hatchobaru	65	51	1.3
Japan.Onuma	13	11	1.2
Japan.Otake	30	34	0.9
U.S.Baca	25	35	0.7

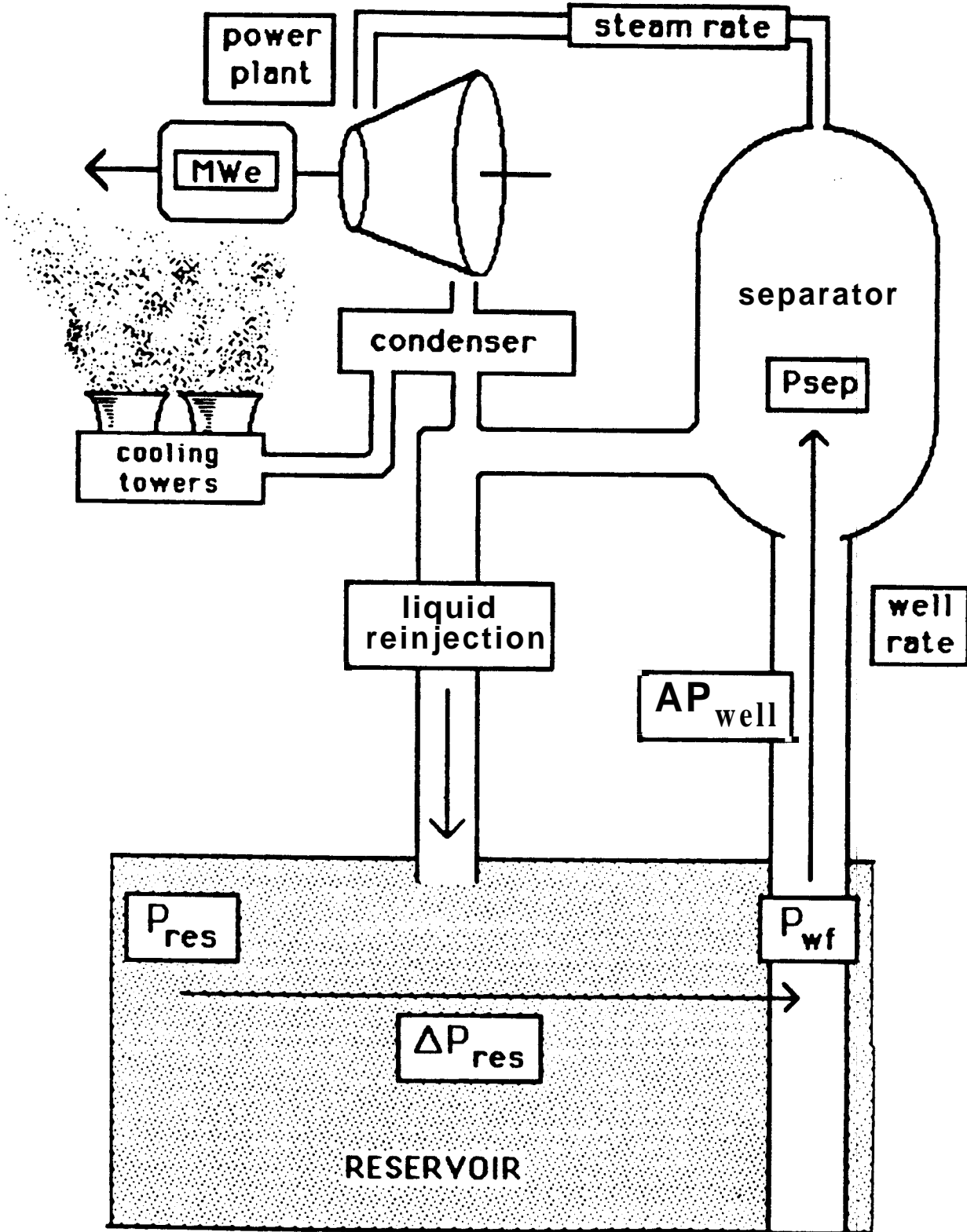

Figure 1 Physical Features of Liquid Dominated Development

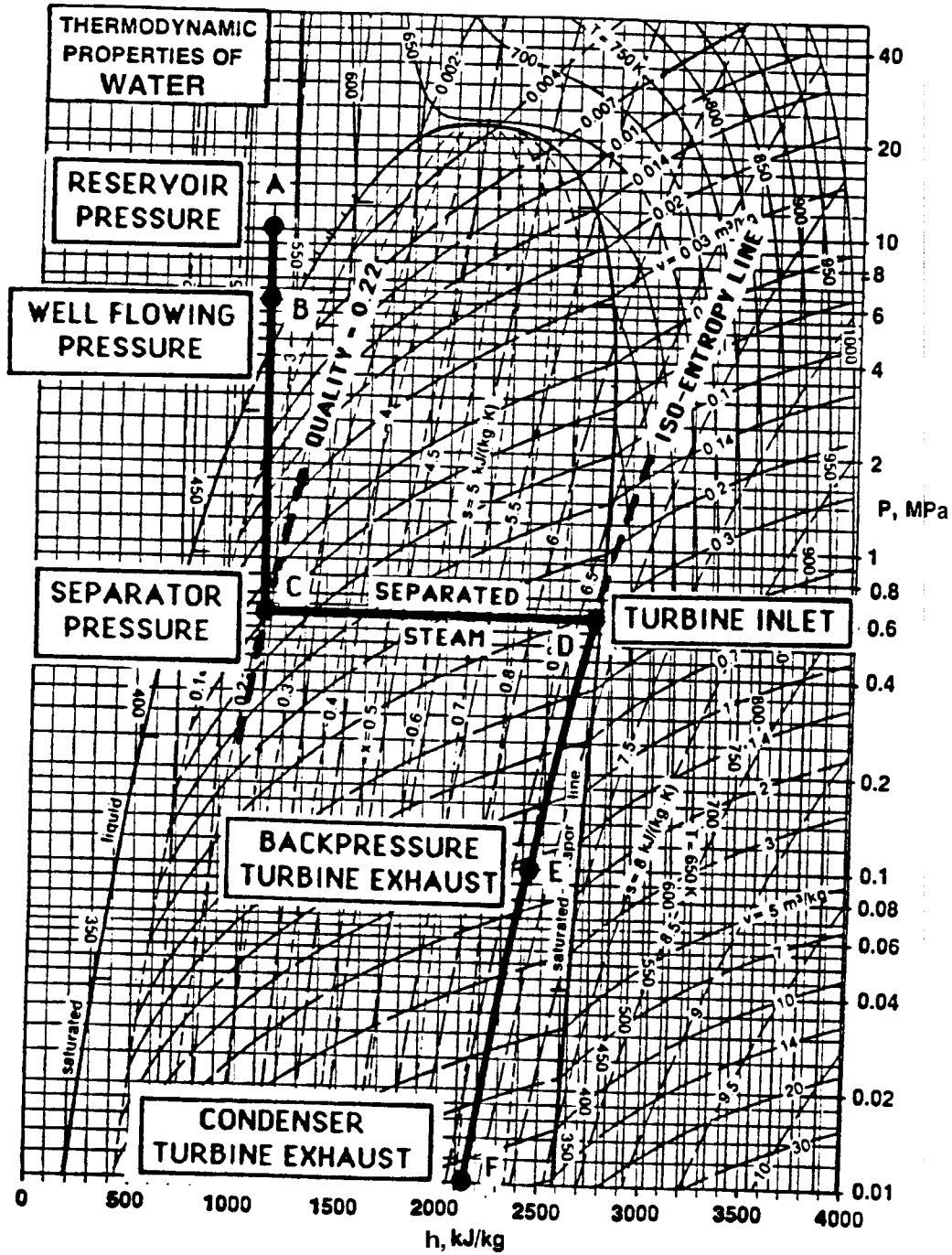

Figure 2 Pressure/Enthalpy Path of Geothermal "Fluid (Reynolds^{4S})

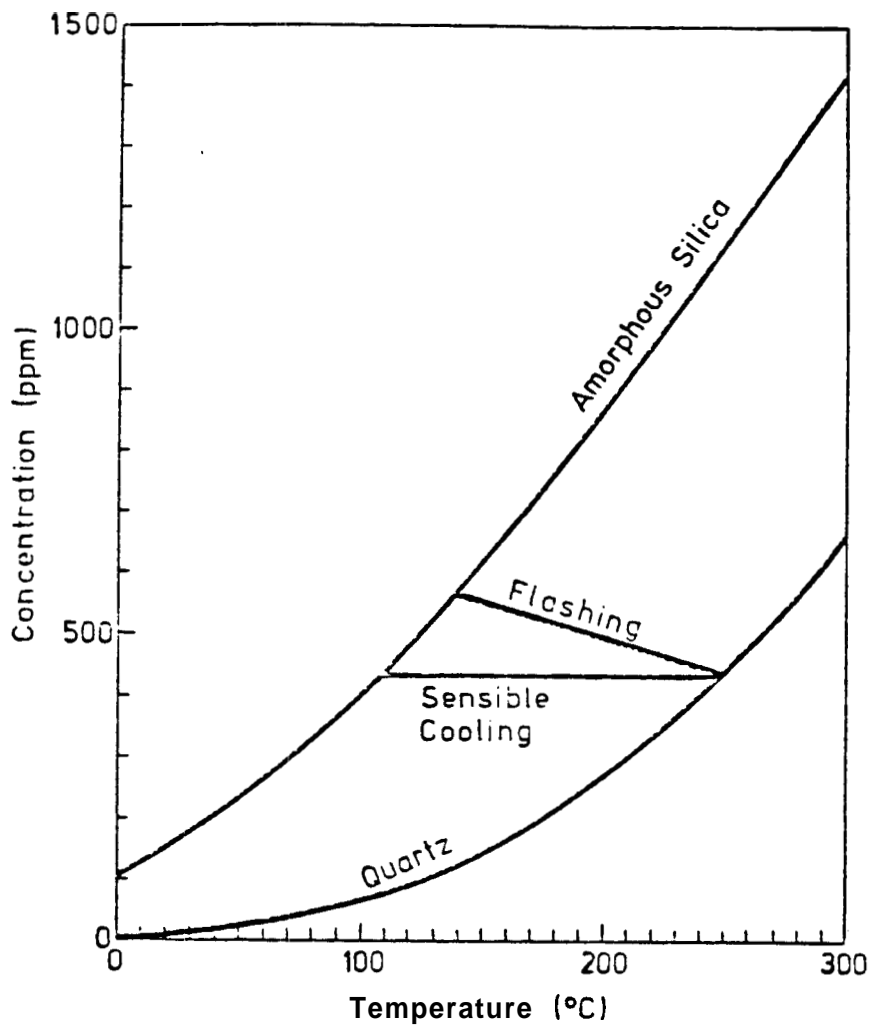

Figure 3 Silica Deposition Constraint (Gudmundsson and Bott³)

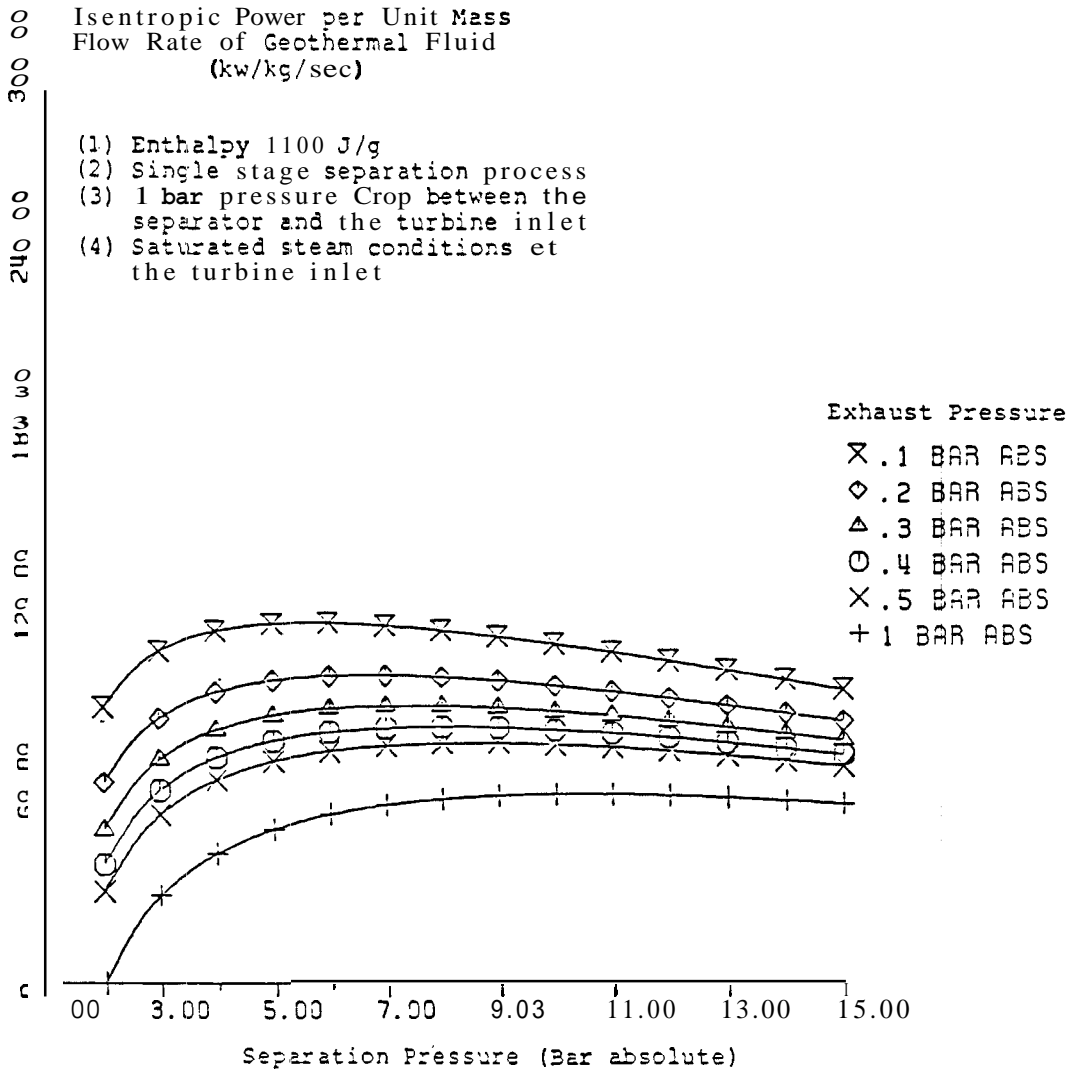

Figure 4 Tauhara Power Optimization Curves (Southan, et. al.⁴)

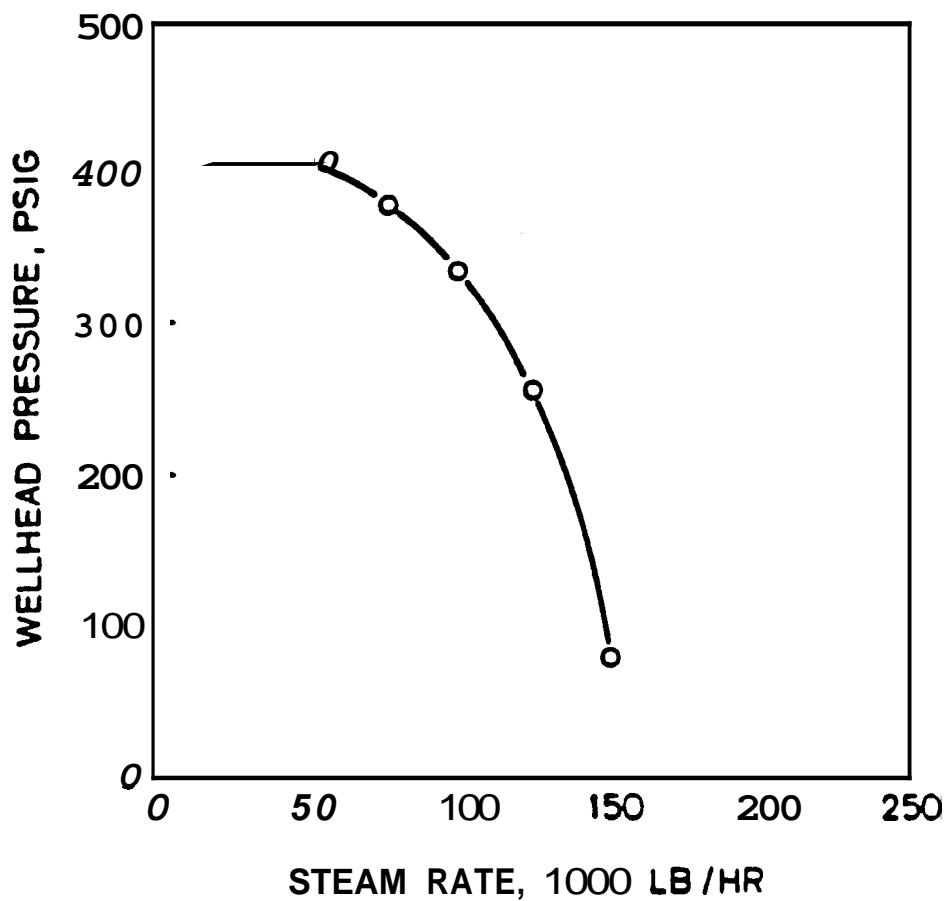

Figure 5 The Geysers • Steam Rate vs. Wellhead Pressure (Ramey⁵)

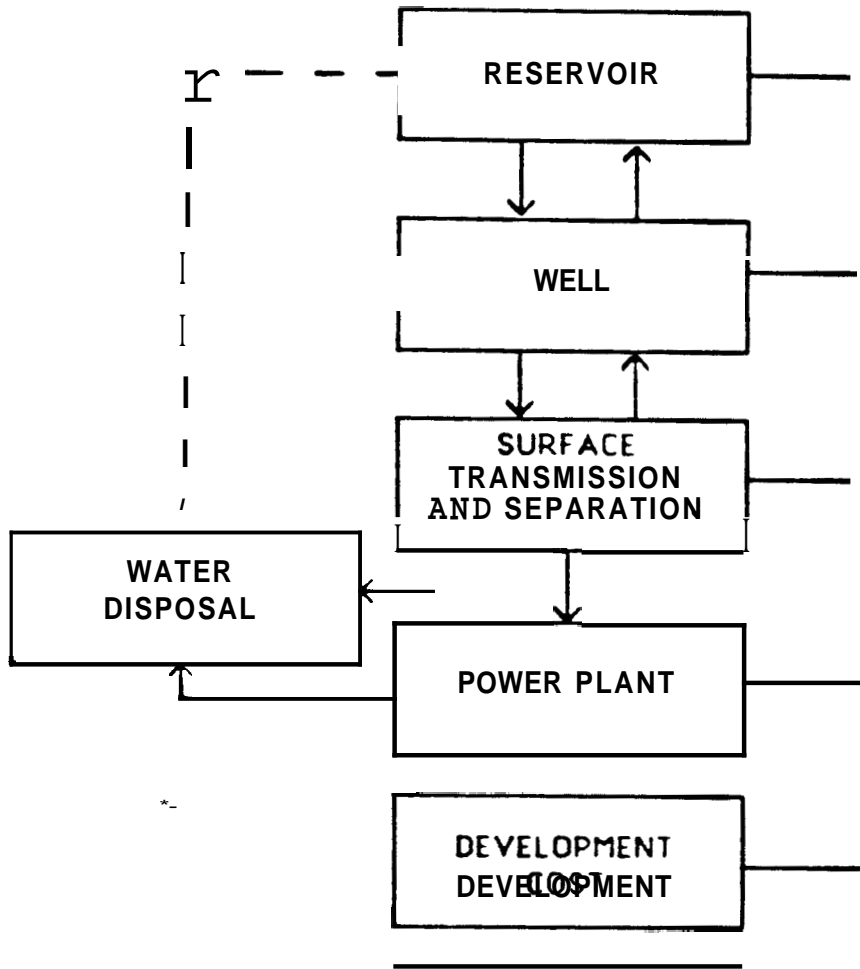

Figure 6 Geothermal Development Block Diagram

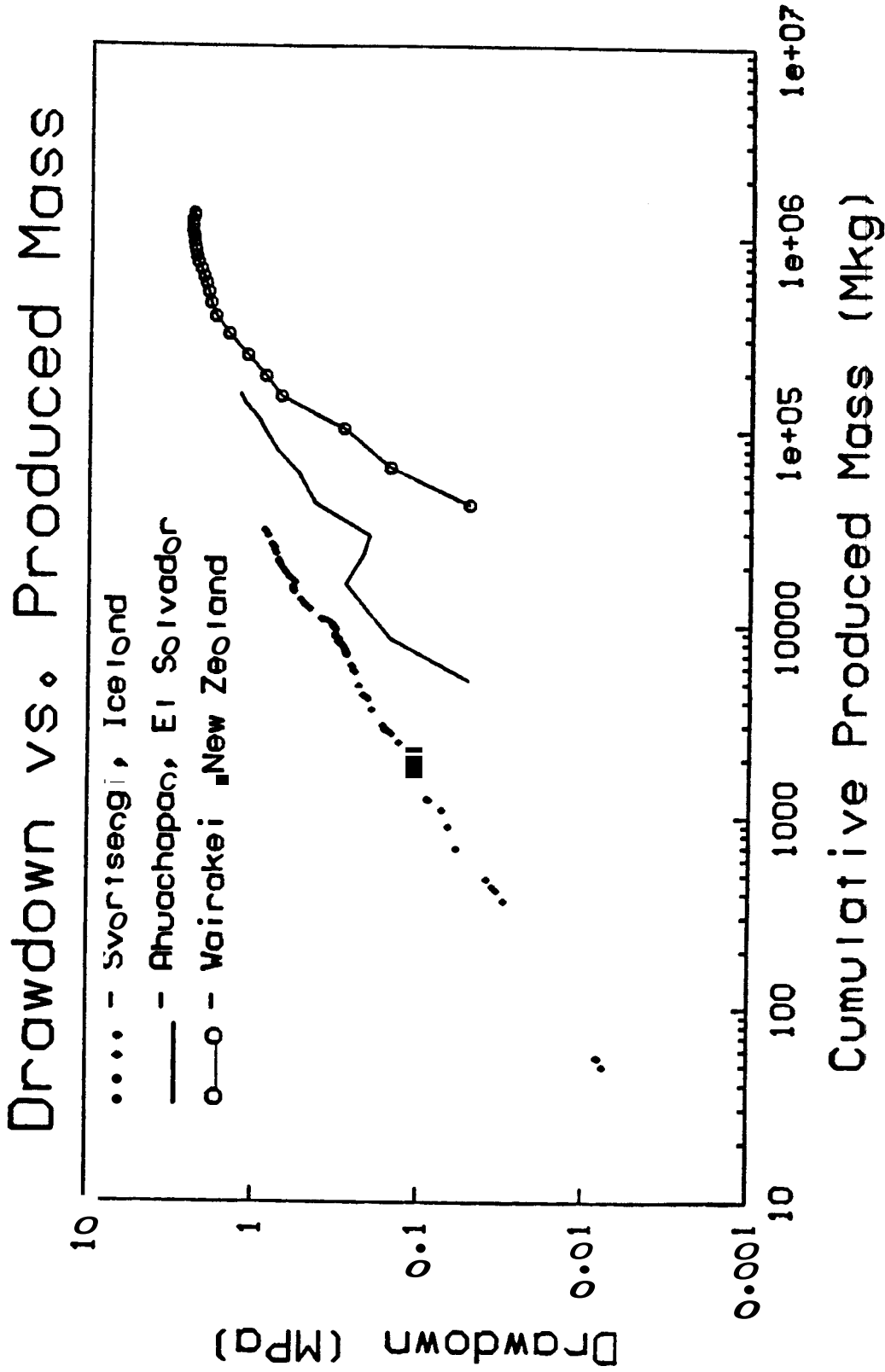

Figure 7 Reservoir Pressure Drawdown vs. Cumulative Produced Mass in Three Liquid Dominated Fields

Svarfssengi - Drawdown vs. Produced Mass

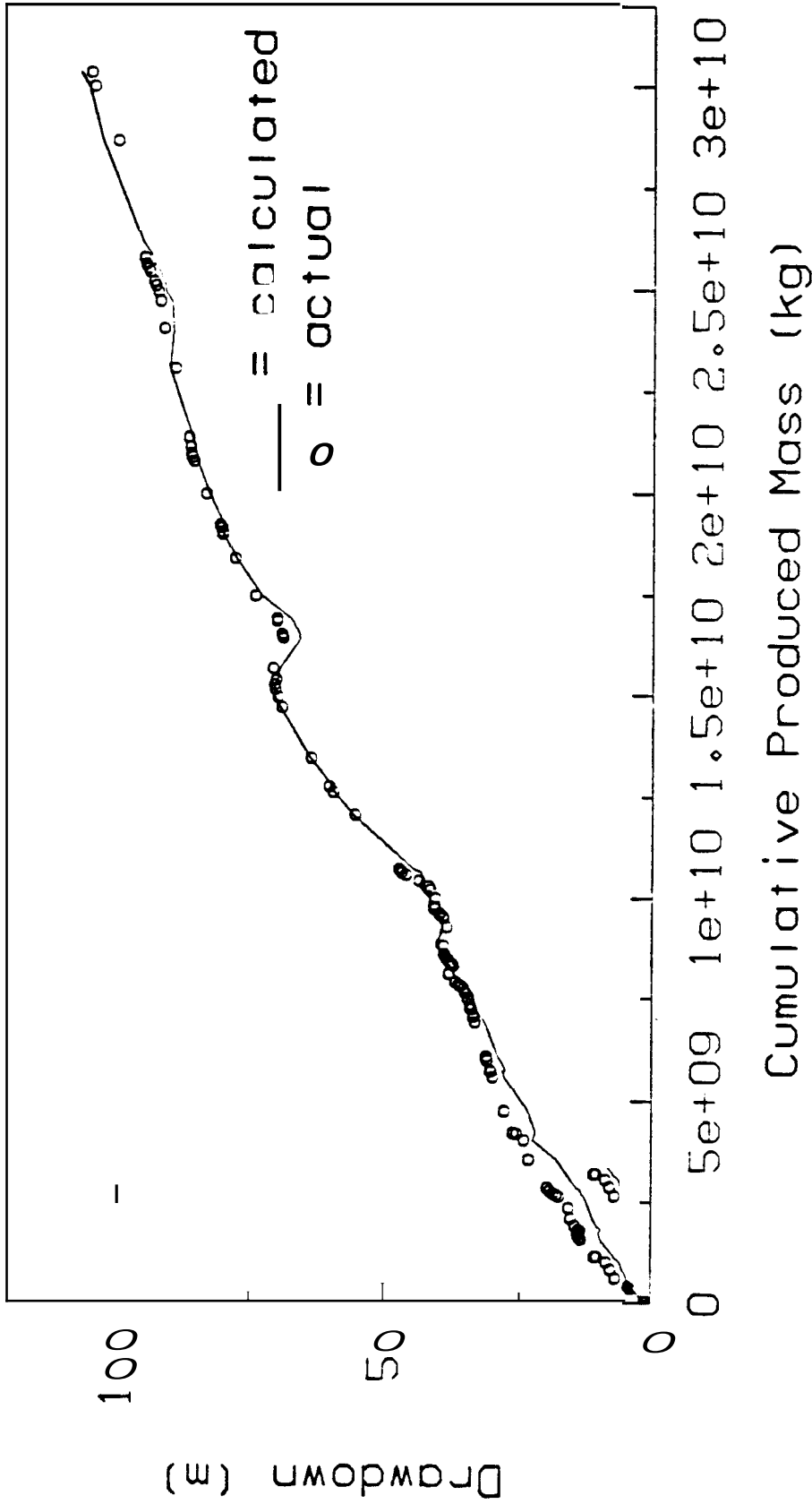

Figure 8 Svarfssengi Drawdown vs. Produced Mass, Field Data and Match with Hurst Simplified Model (Gudmundsson and Olsen¹⁵)

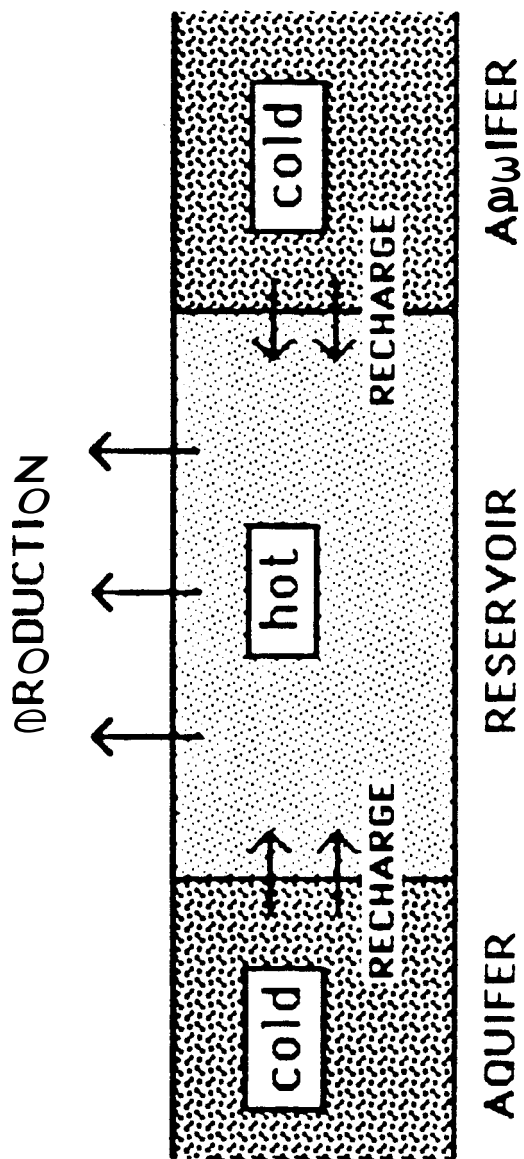

Figure 9 Hurst Simplified Reservoir and Aquifer Two-Lump Model

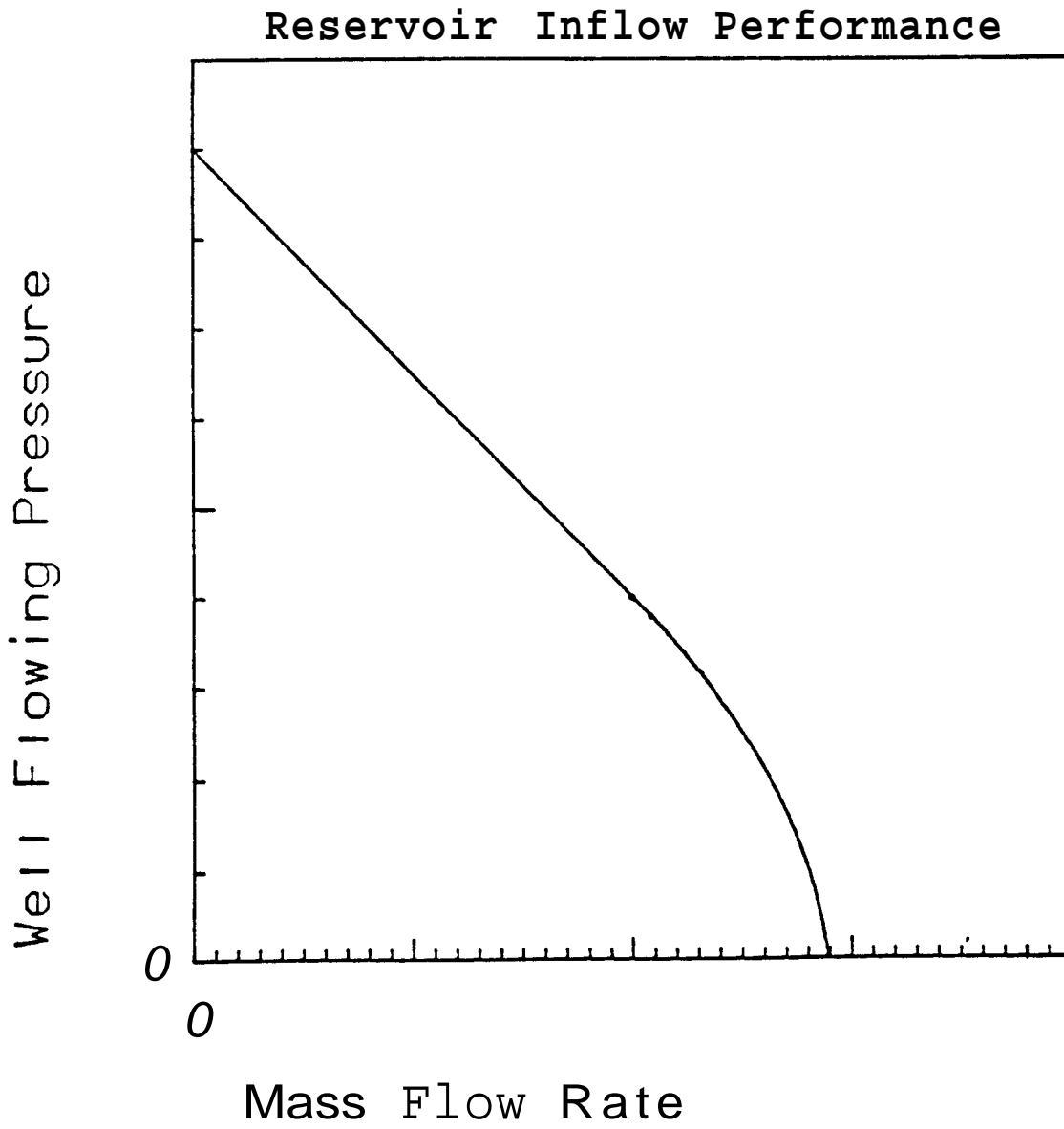

Figure 10 General Reservoir Inflow Performance Curve

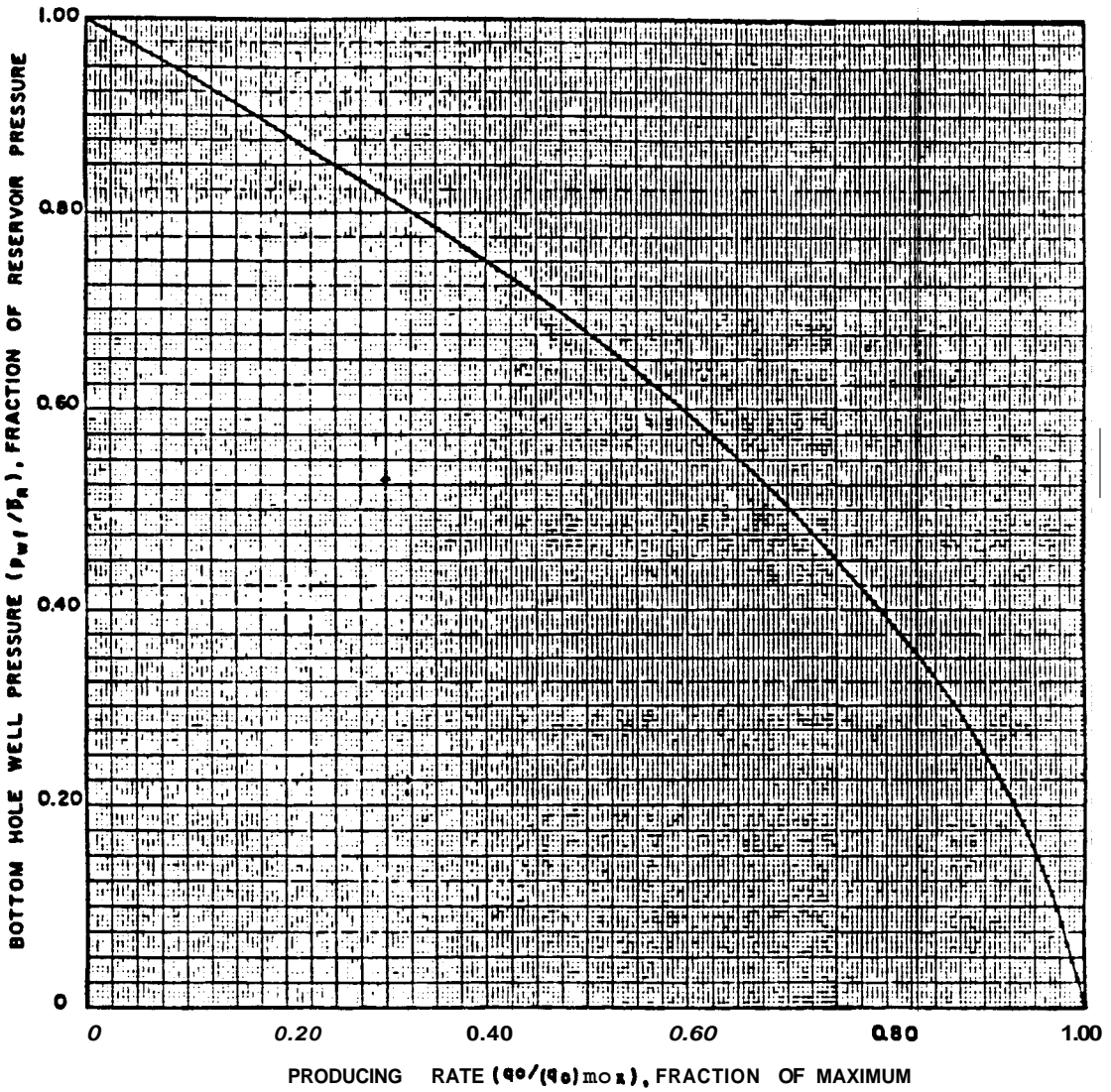

Figure 11 Vogel²⁴ Solution Gas IPR

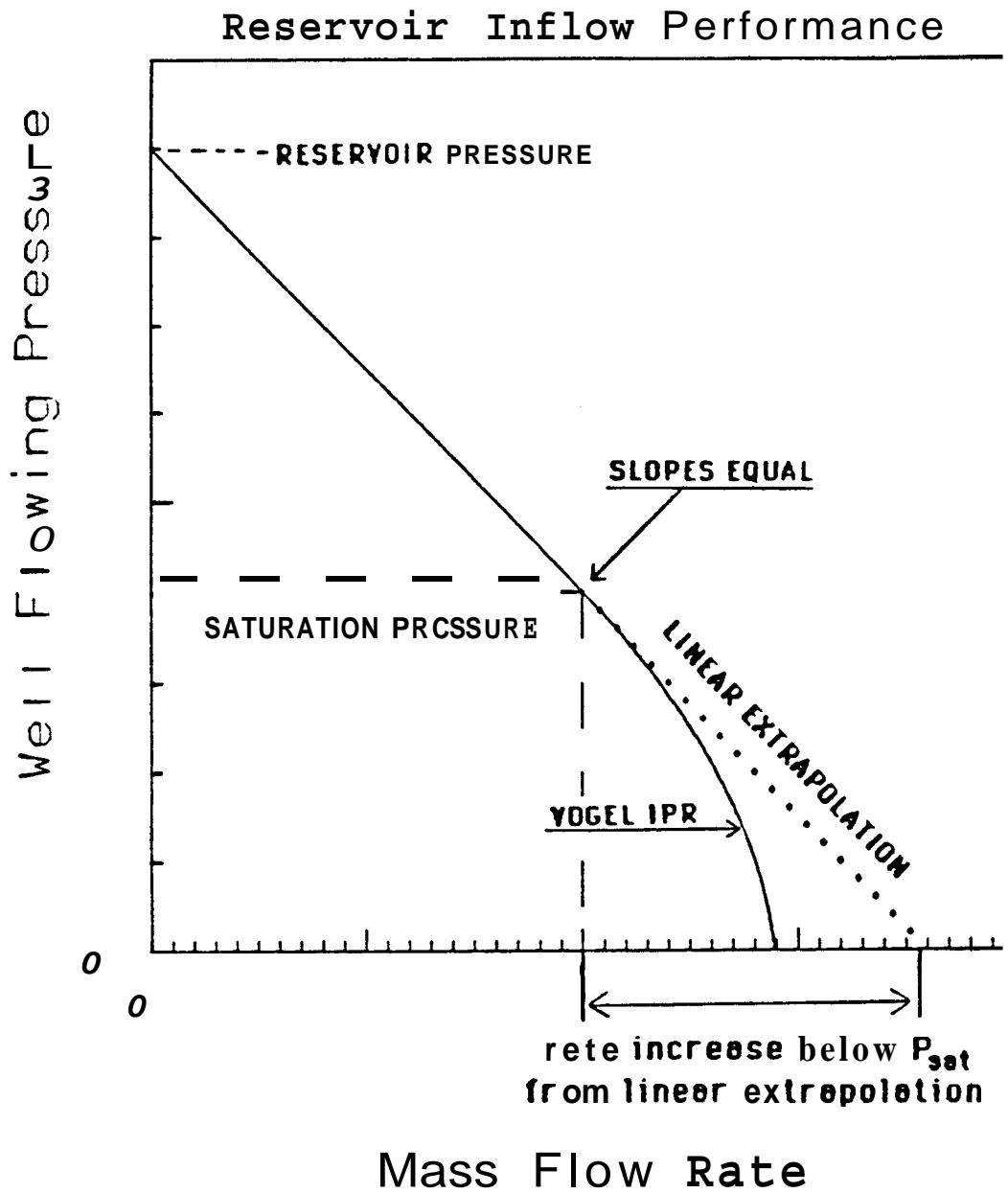

Figure 12 Reservoir Inflow Performance Curve with Details of Construction Above and Below the Saturation Pressure

Roosevelt Data and Reservoir Inflow Performance Comparison

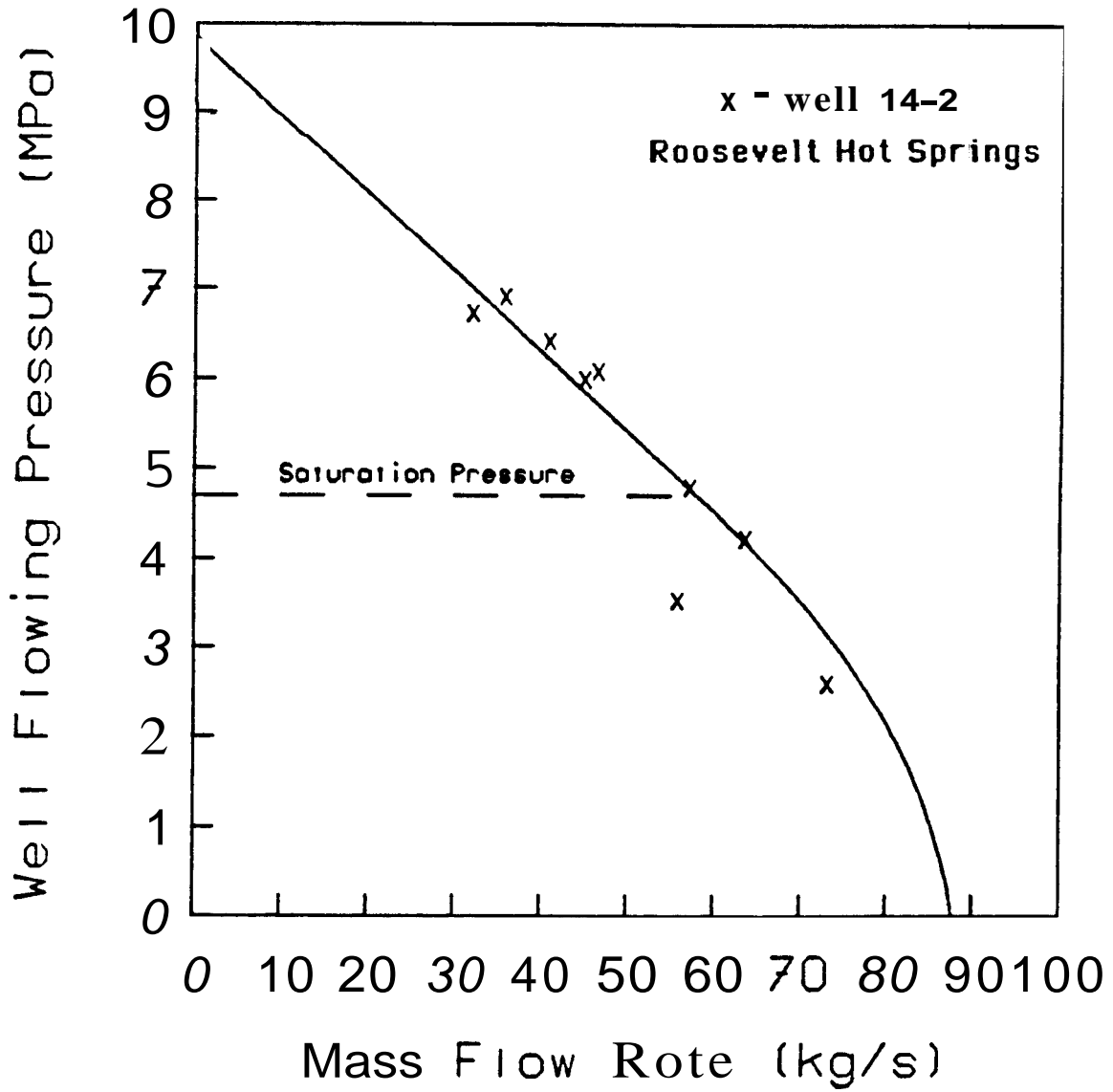

Figure 13 Reservoir Inflow Performance Curve Compared to Roosevelt Data

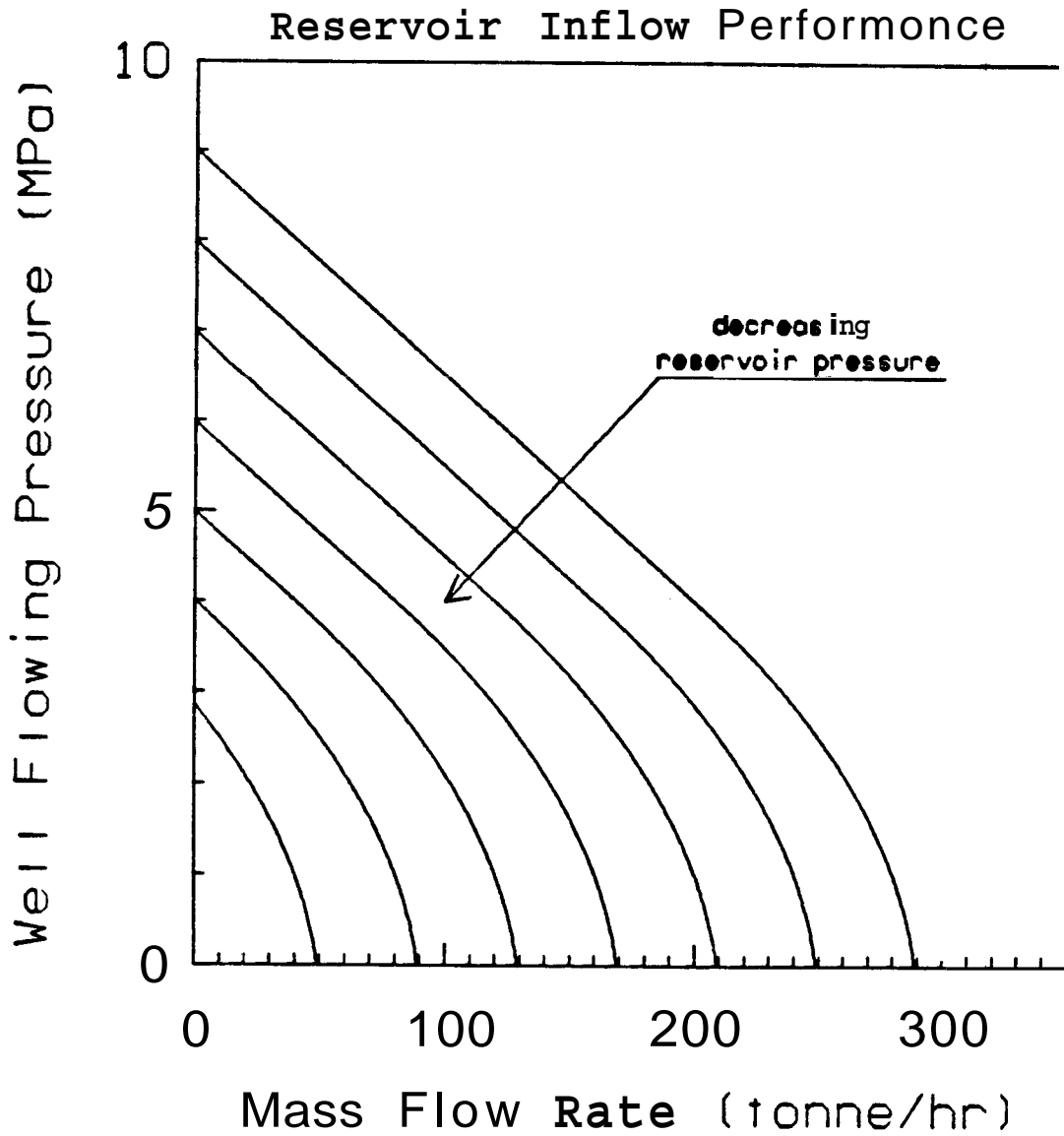

Figure 14 Effect of Decreasing Reservoir Pressure on Reservoir Inflow Performance

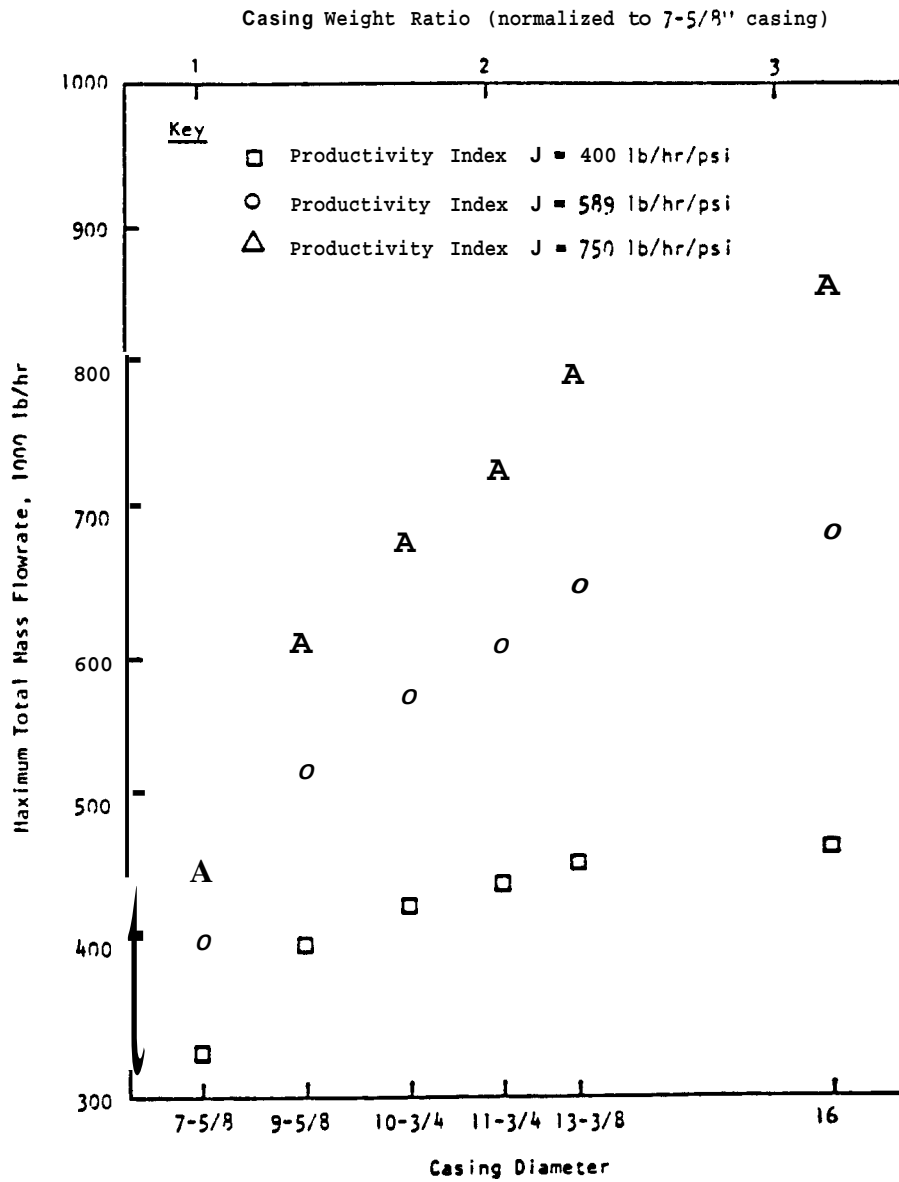

Figure 15 Mass Rate vs. Well Size and Productivity Index (Butz²⁸)

WELL PERFORMANCE CURVES

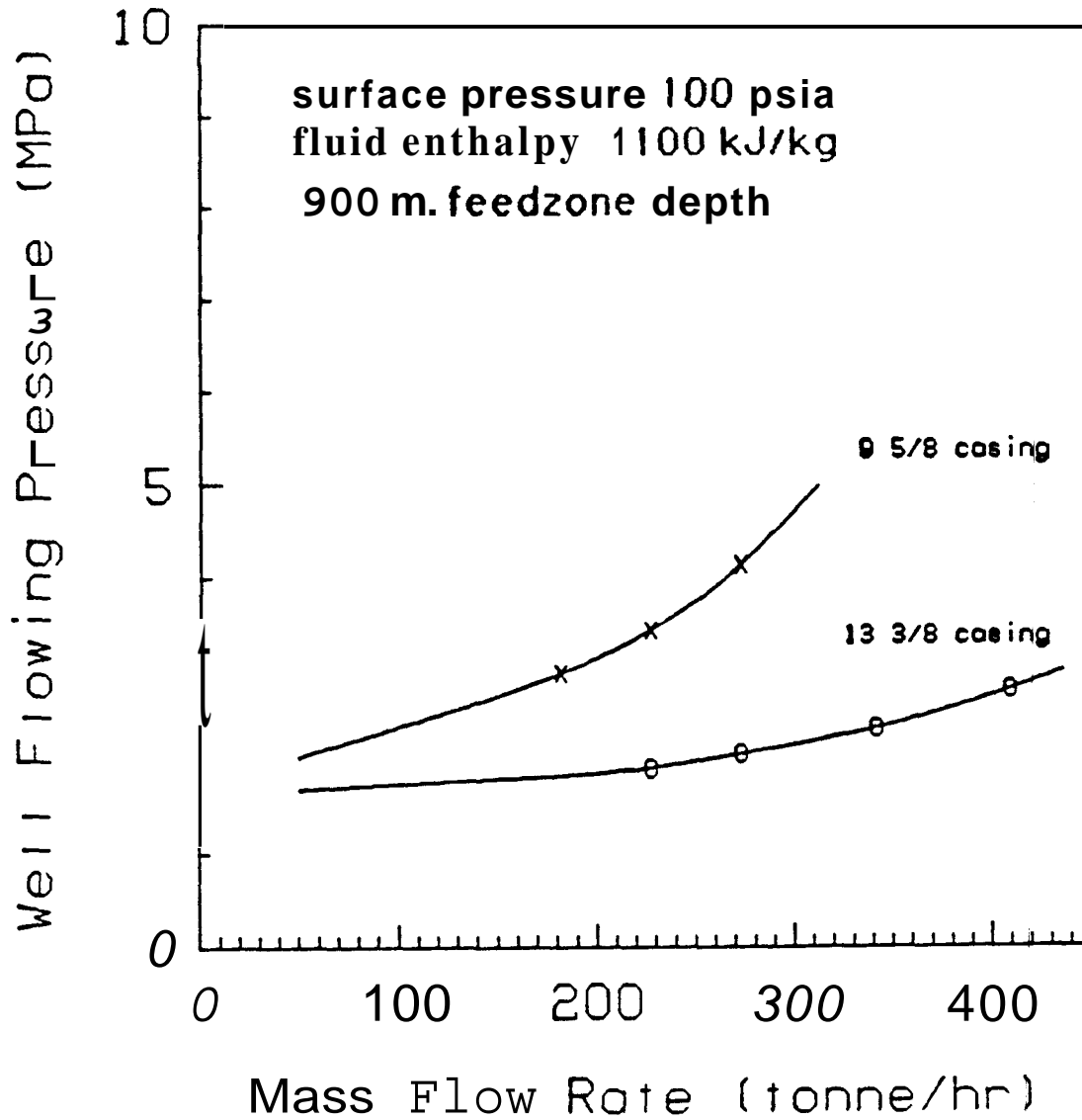

Figure 16 Well Performance Curves Derived from Roosevelt Data

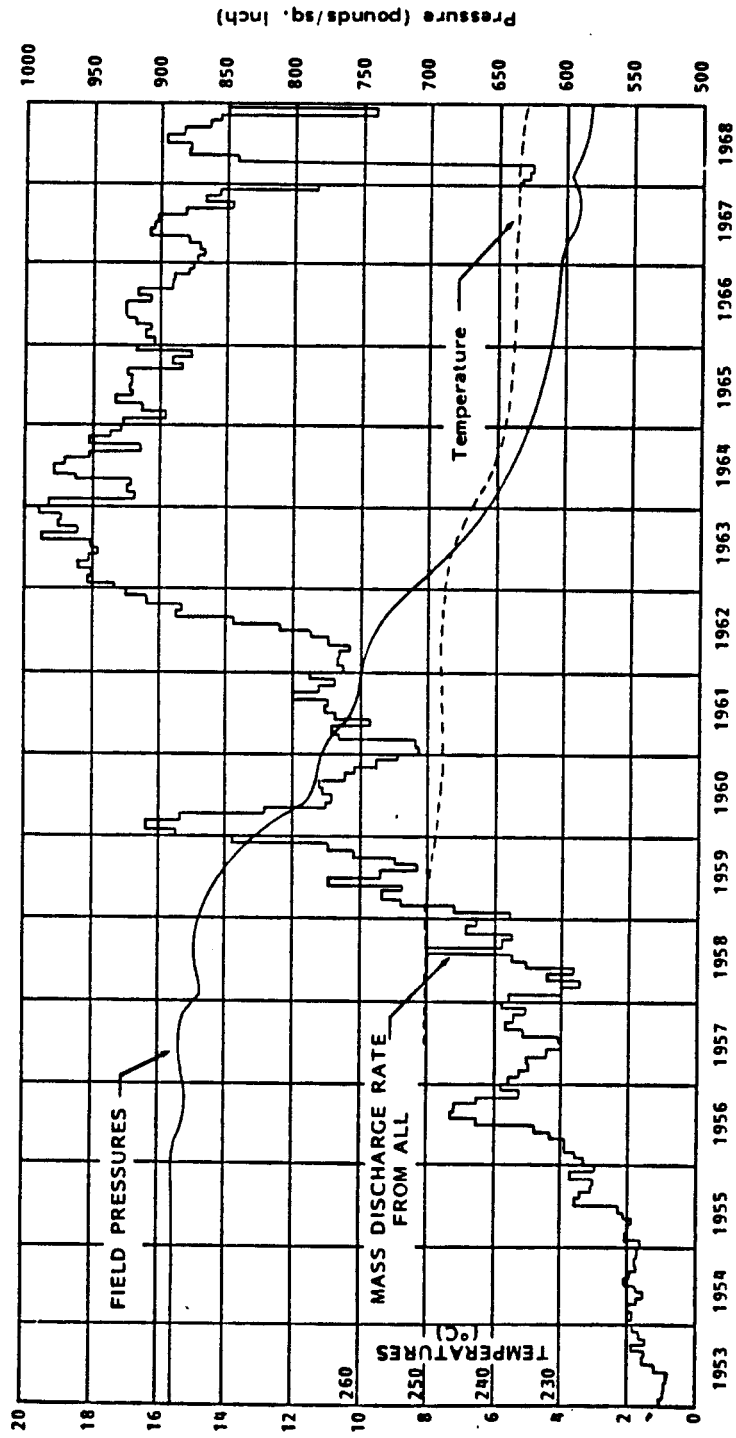

Figure 17 Wairakei Production Data (Love and Bolton¹¹)

PREDICTION

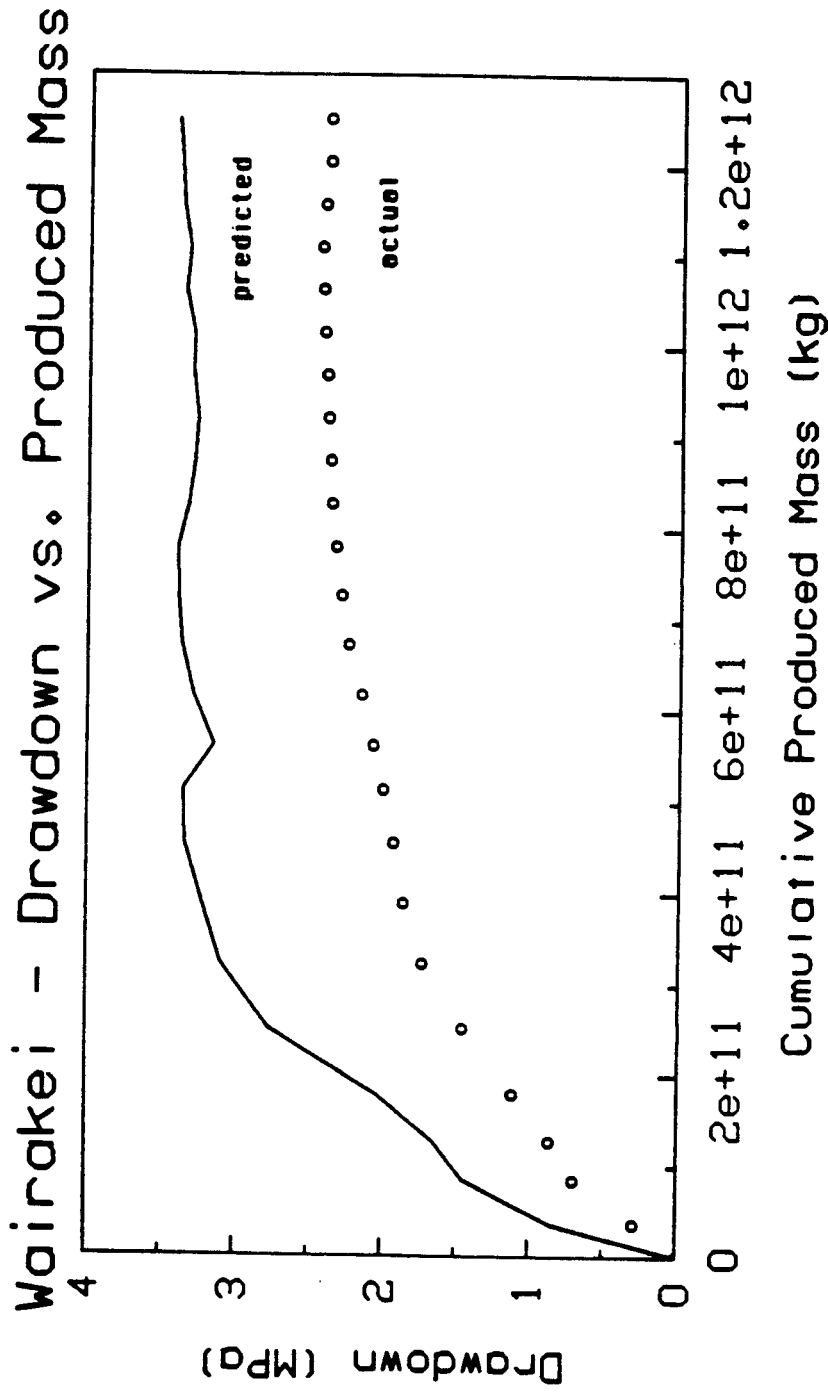

Figure 18 Wairakei - Predicted and Actual Drawdown vs. Cumulative Produced Mass

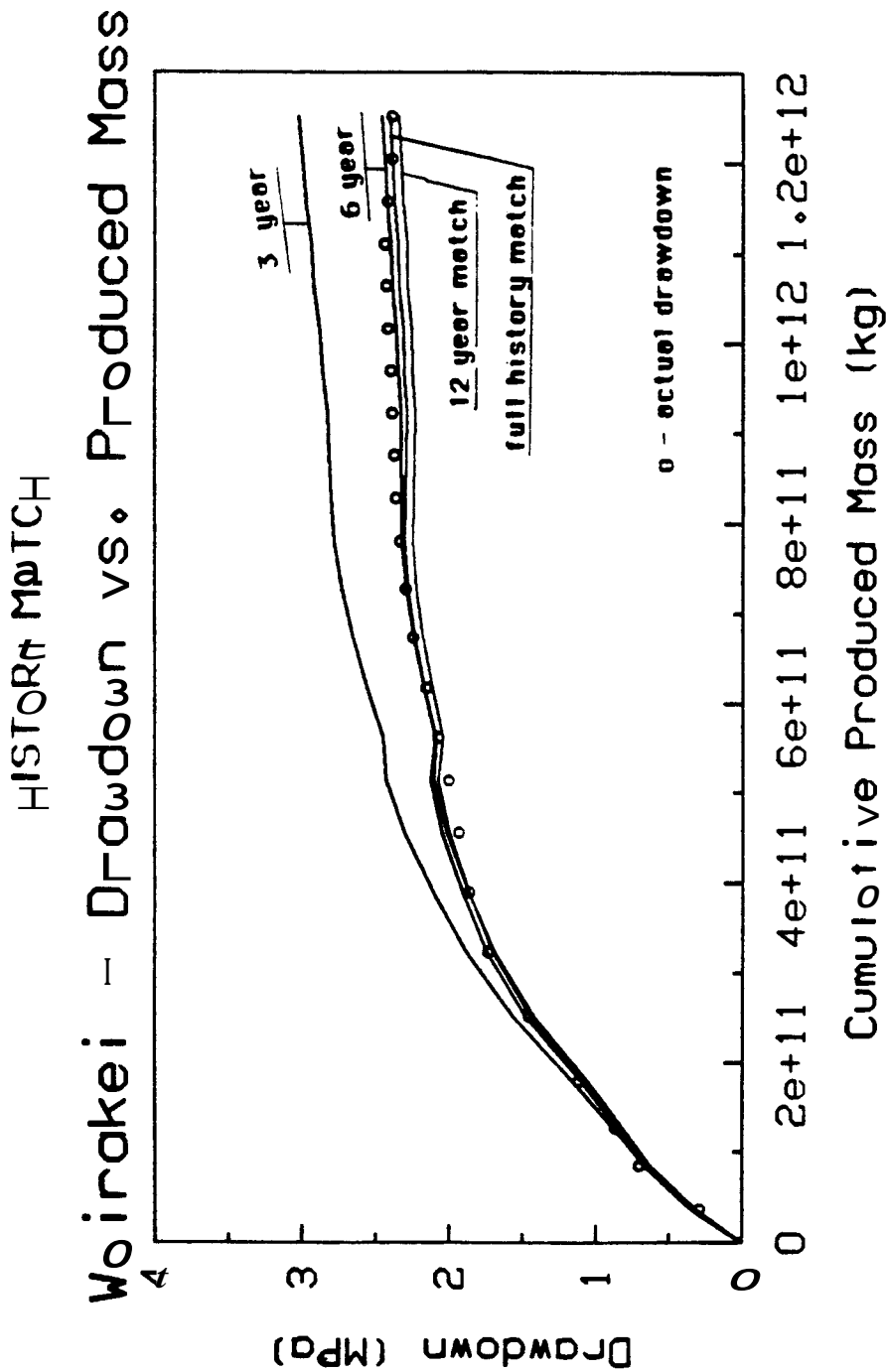

Figure 19 Wairakei - History Match and Forecast of Drawdown vs. Cumulative Produced Mass

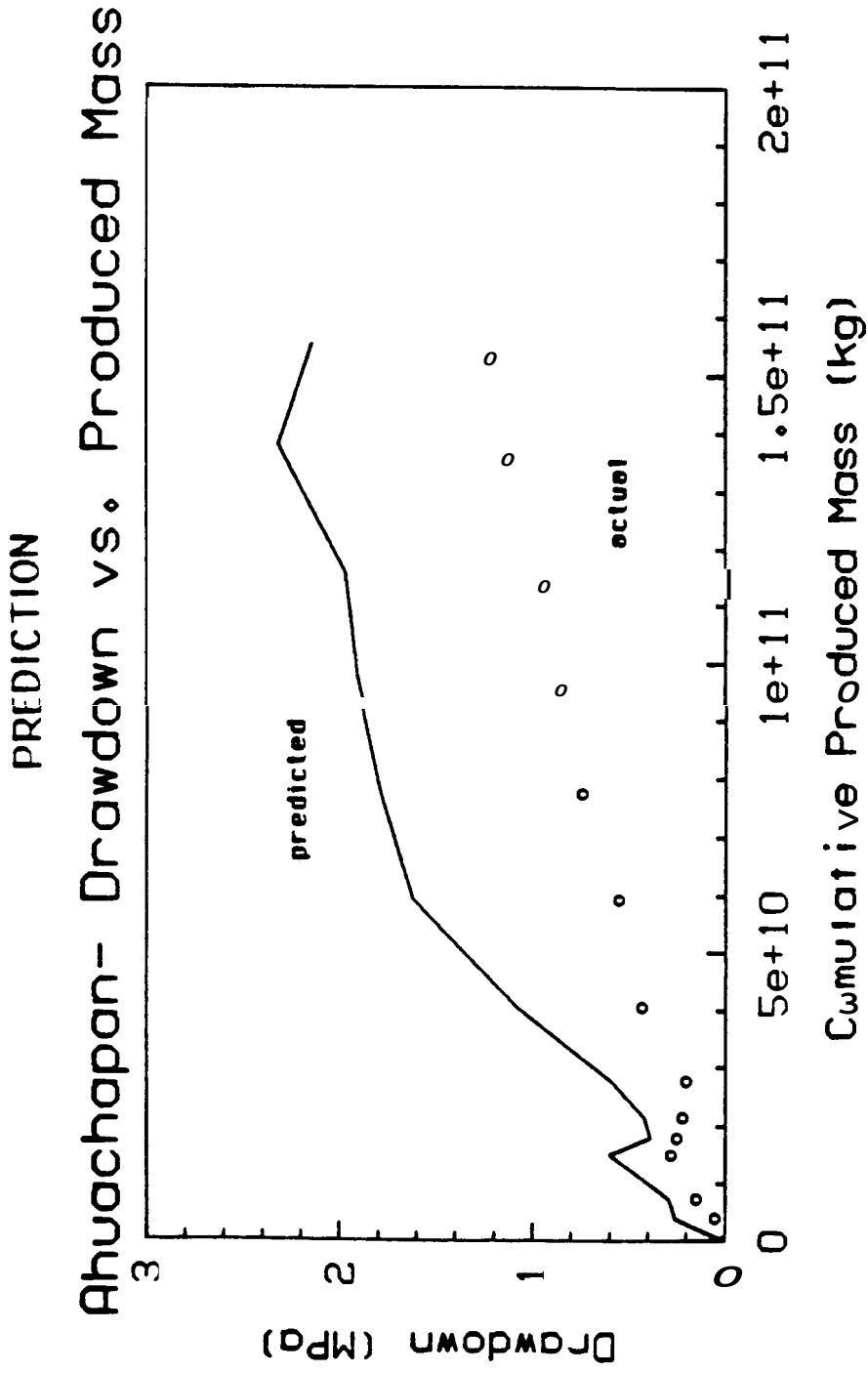

Figure 20 Ahuachapan - Predicted and Actual Drawdown vs. Cumulative Produced Mass

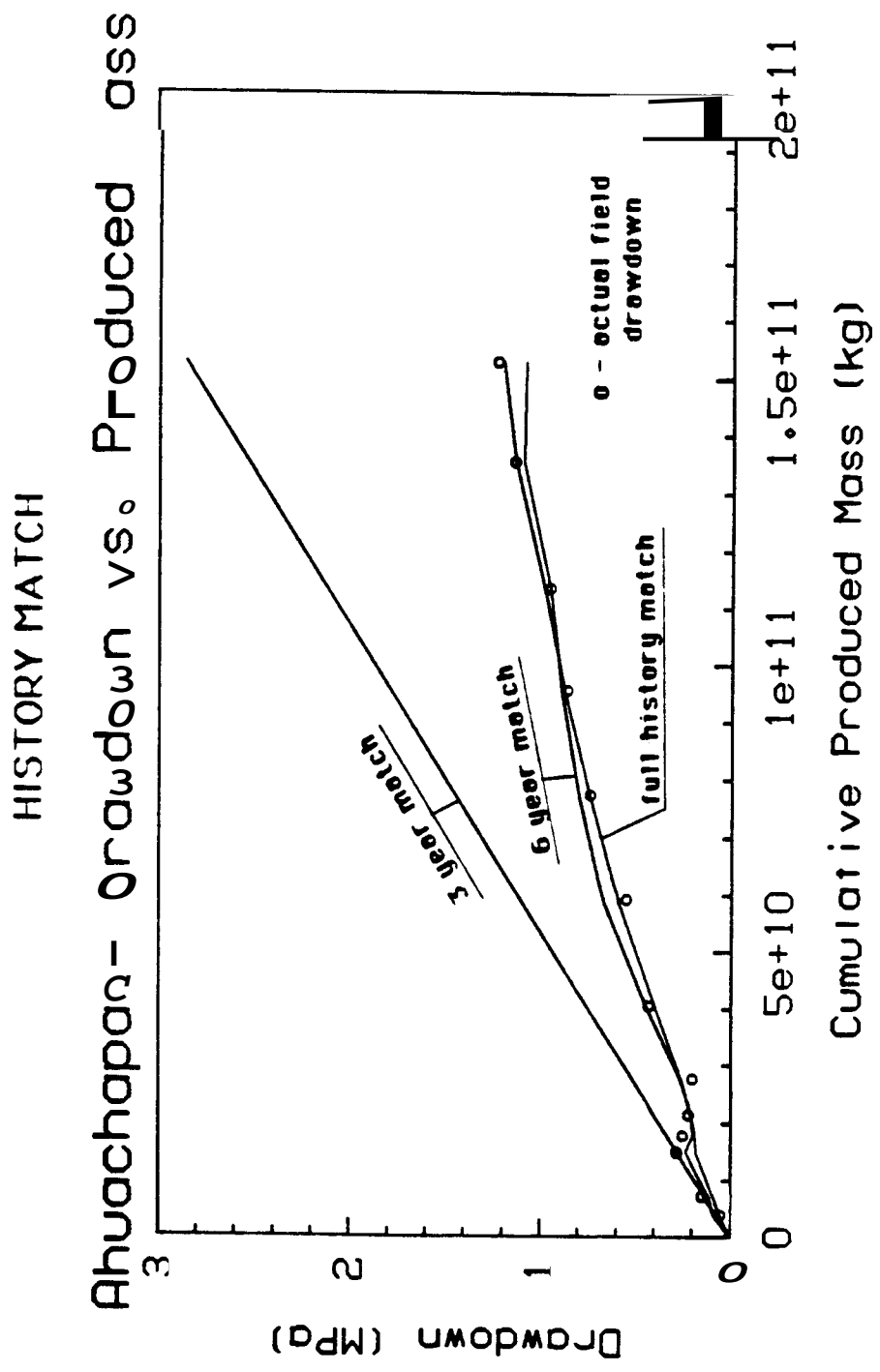

Figure 21 Ahuachapan - History Match and Forecast of Drawdown vs. Cumulative Produced Mass

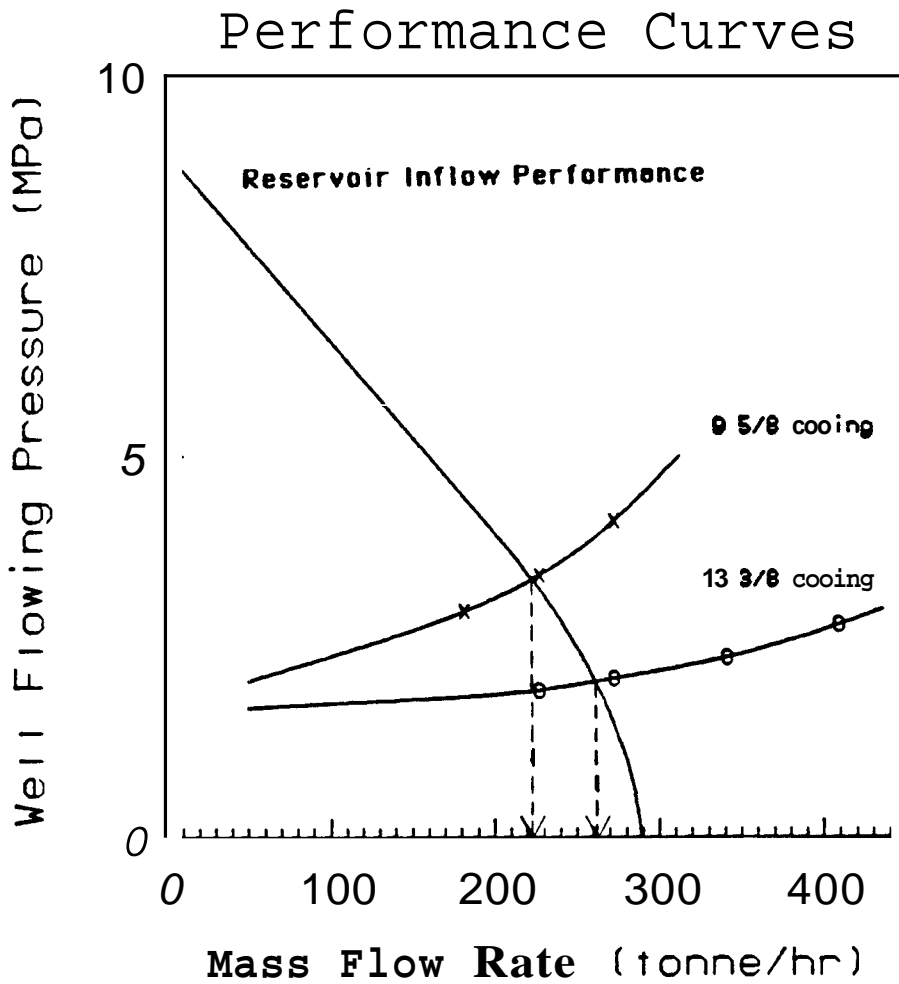

Figure 22 Reservoir Inflow Performance and Well Performance Based on Roosevelt Data

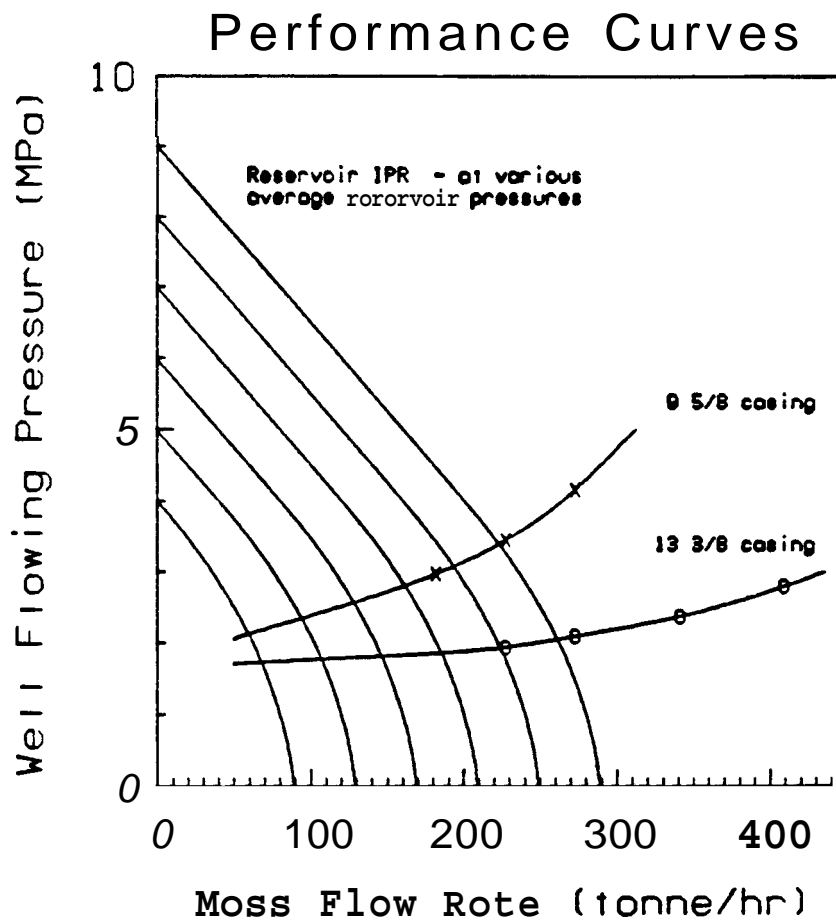

Figure 23 Reservoir **Inflow** Performance and Well Performance Based on Roosevelt Data for Different Reservoir Pressures

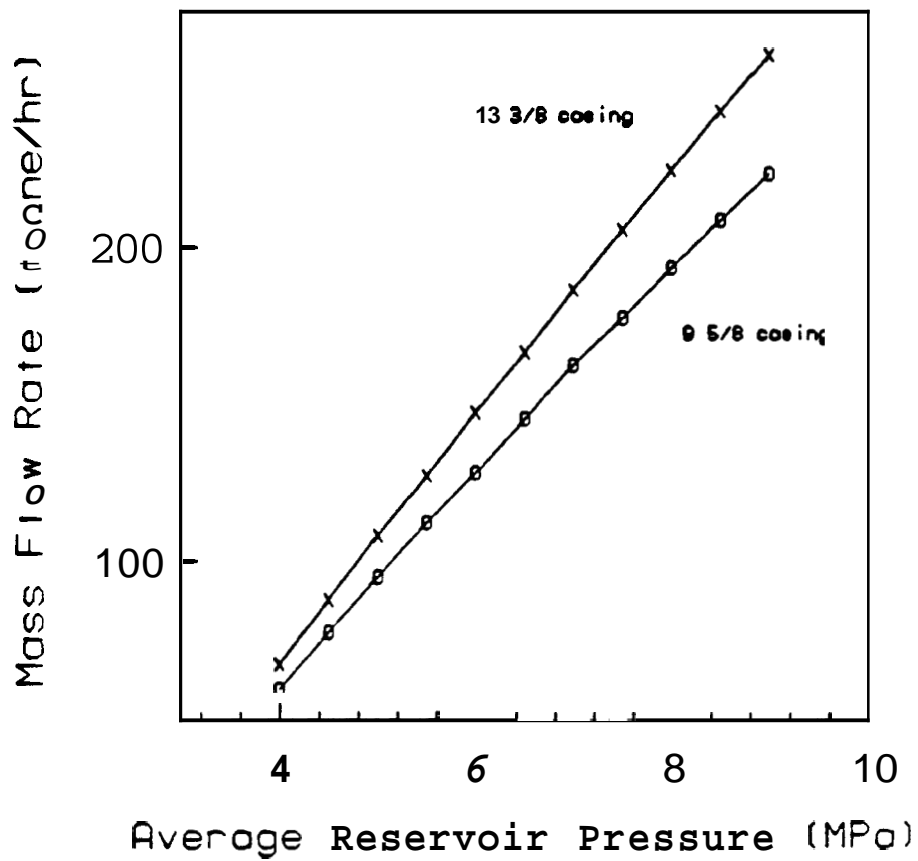

Figure 24 Mass Rate vs. Reservoir Pressure Derived from Reservoir Inflow Performance and Well Performance Based on Roosevelt Data for Different Reservoir Pressures

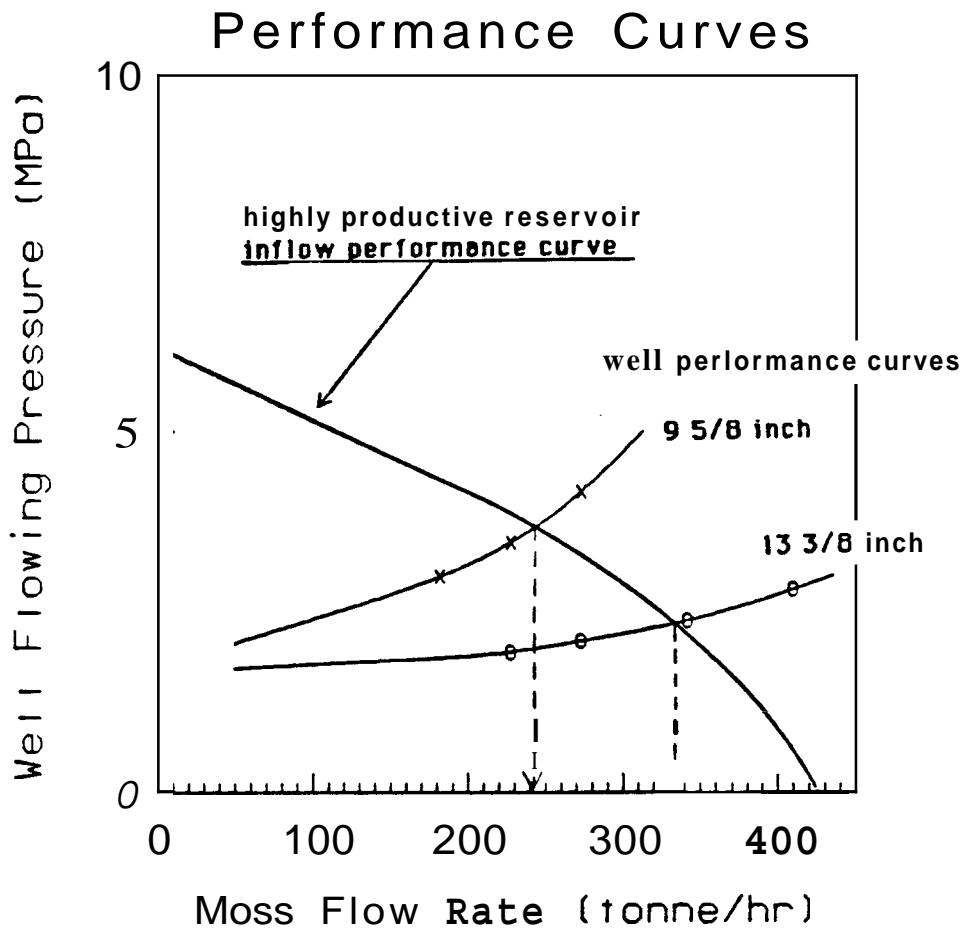

Figure 25 Reservoir Inflow Performance, Based on Svartsengi P.I., and Well Performance, Based on Roosevelt Data

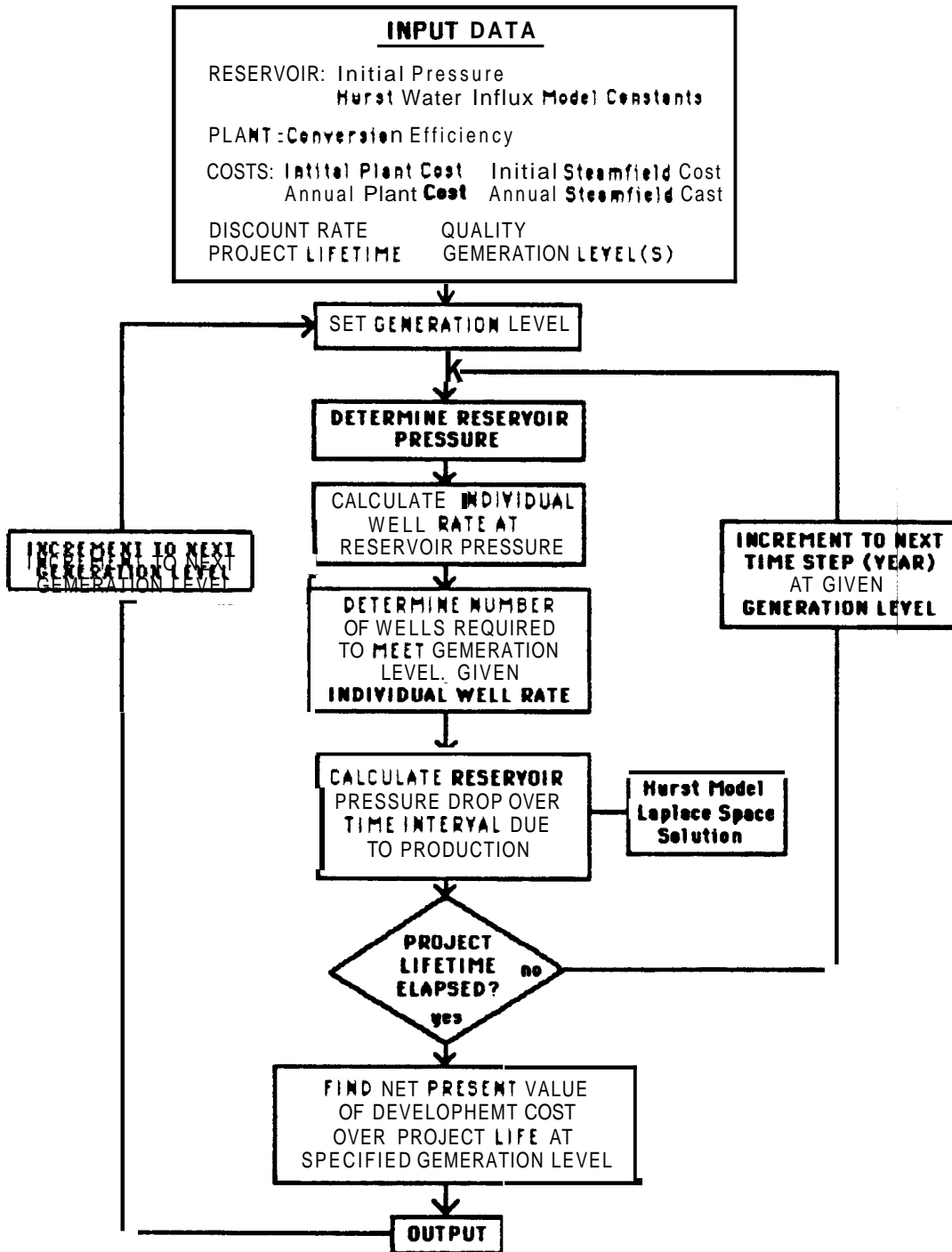

Figure 26 Flowchart for Development Model Program

DEVELOPMENT COST VS. GENERATION LEVEL

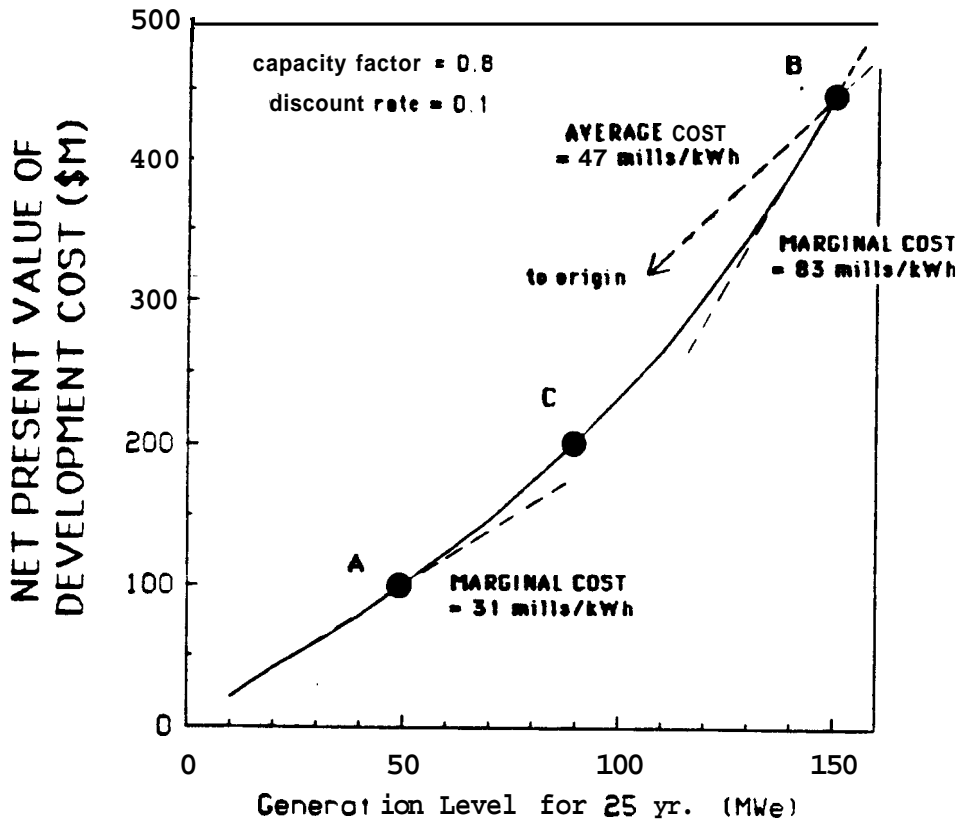

Figure 27 General Result for Net Present Value of Development Cost vs. Generation Level

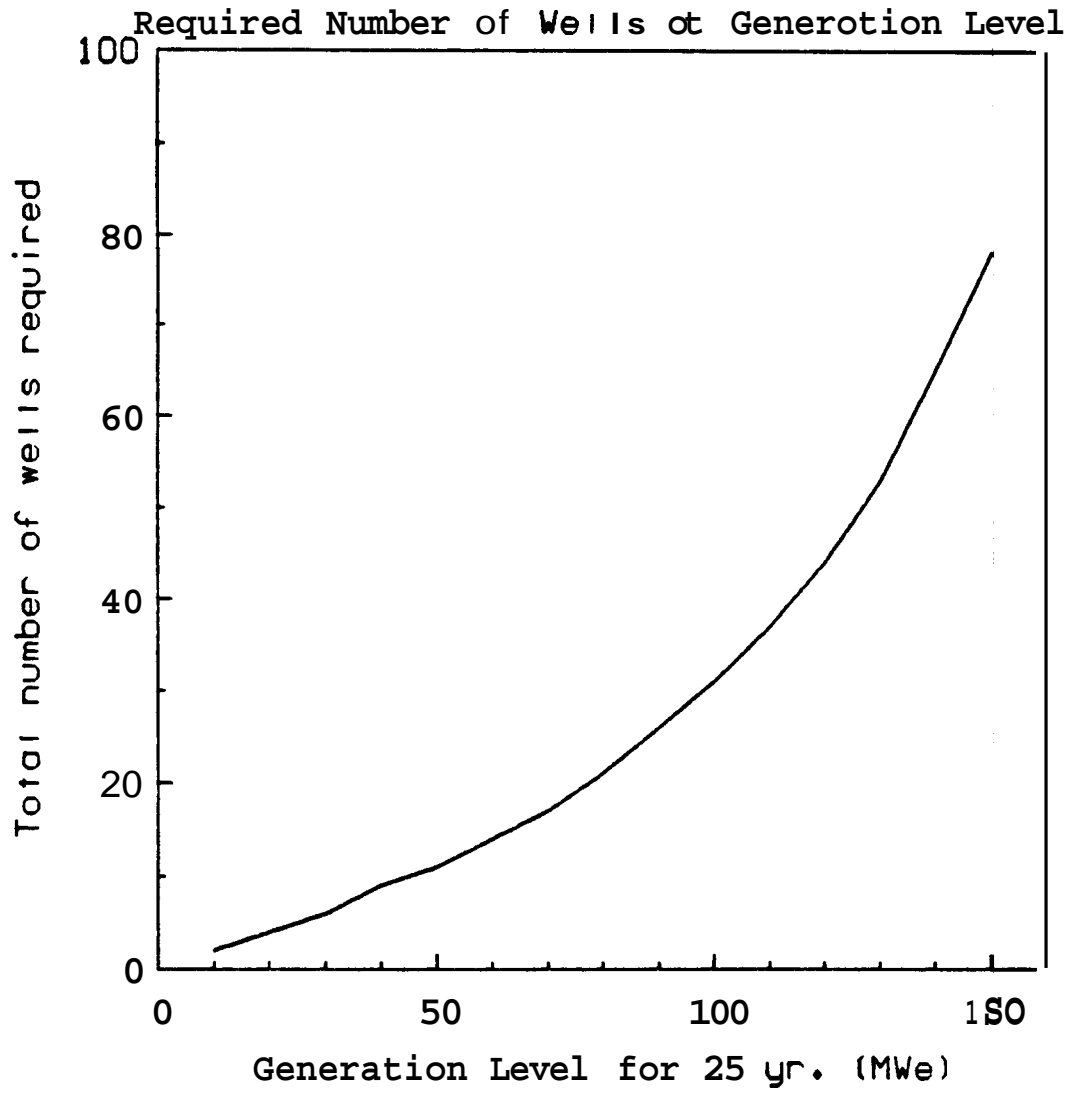

Figure 28 Total Number of Wells Required vs. Generation Level

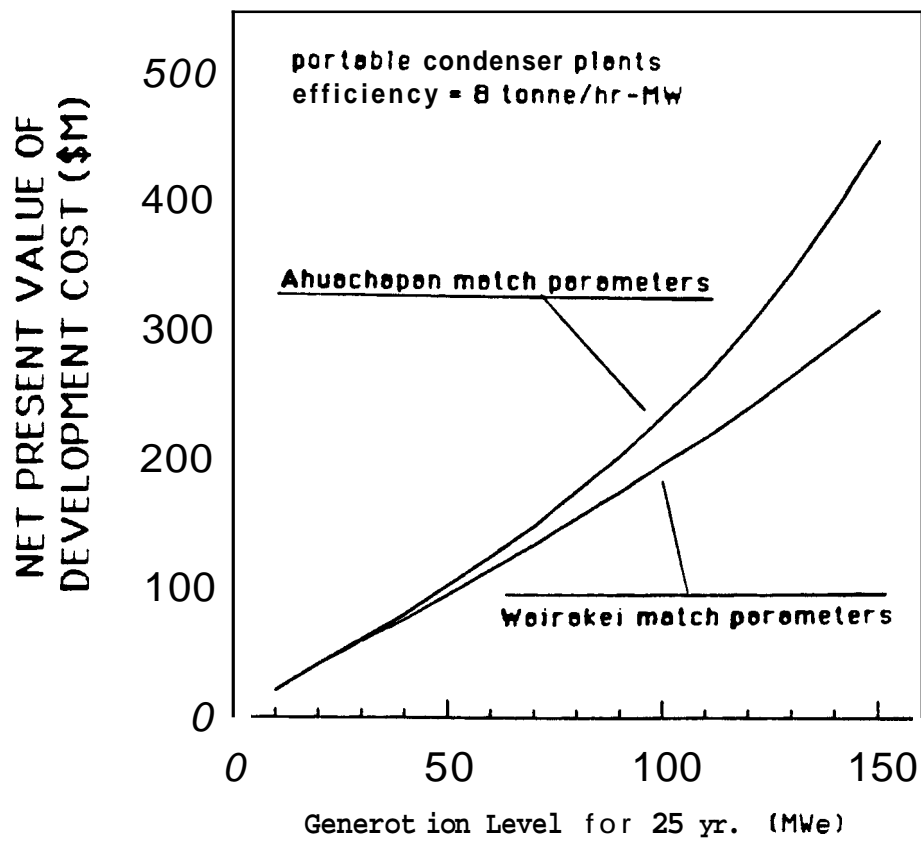

Figure 29 Effect of Different Reservoir Drawdown Behavior on Development Cost

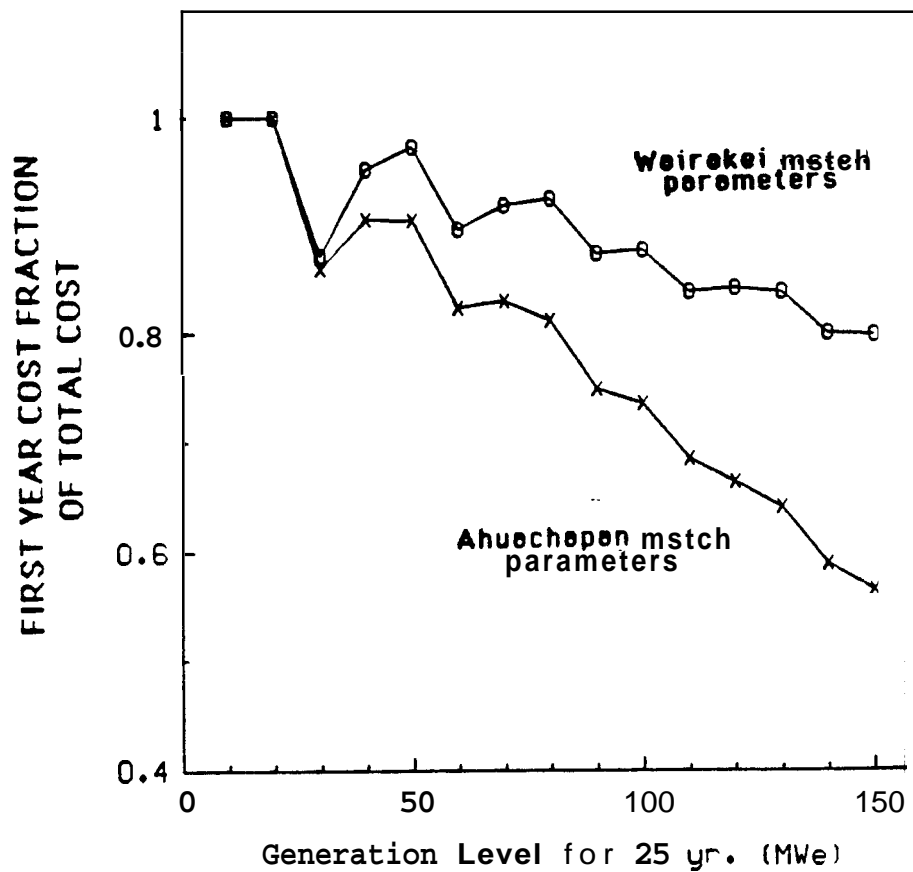

Figure 30 First Year Cost Fraction of Development Cost vs. Generation Level for Two Reservoir Scenarios

EFFECT OF PLANT CHOICE WITH AHUACHAPAN MATCH PARAMETERS

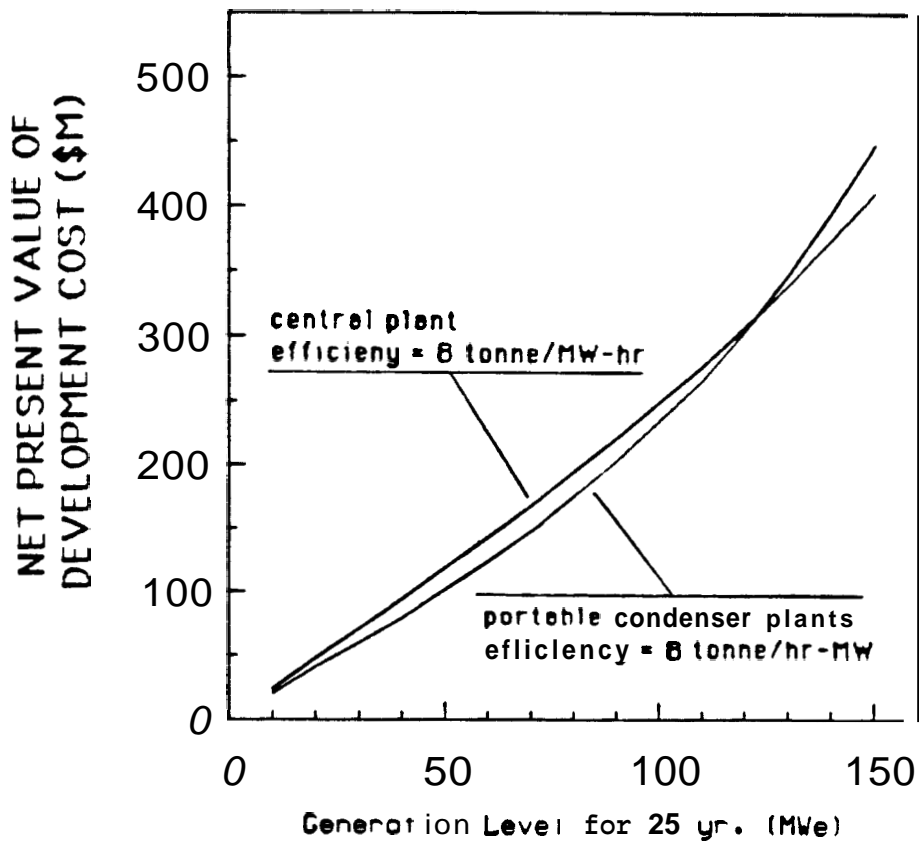

Figure 31 Effect of Plant Choice on Development Cost with Ahuachapan Match Parameters

EFFECT OF PLANT CHOICE WITH WAIRAKEI MATCH PARAMETERS

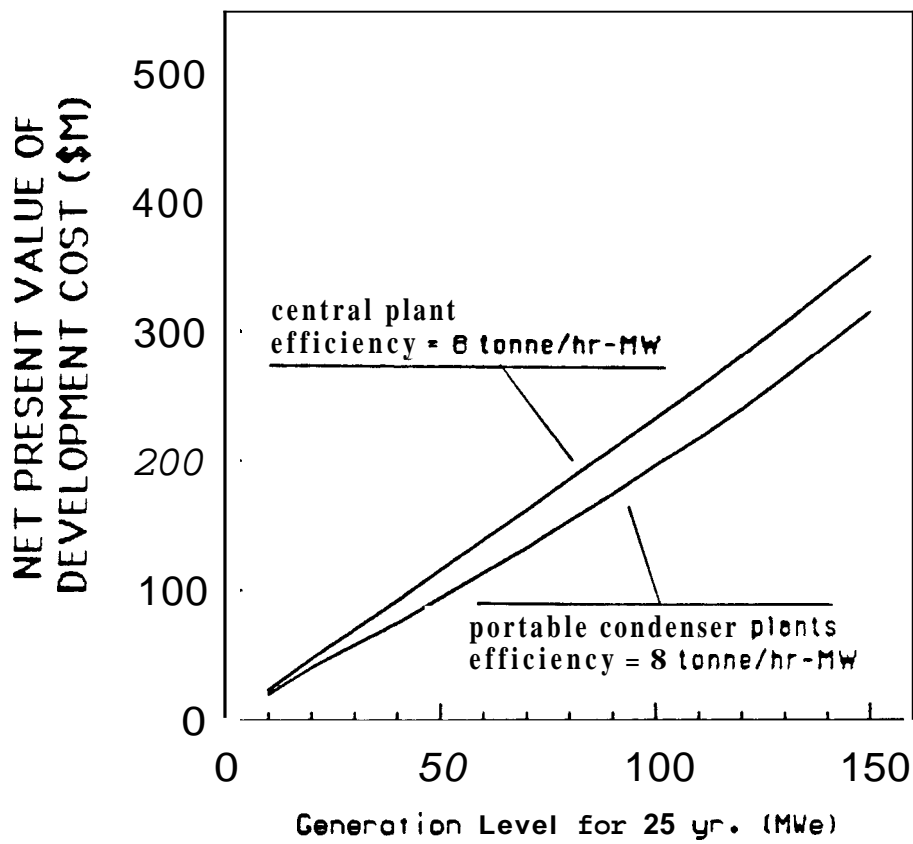

Figure 32 Effect of Plant Choice on Development Cost with Wairakei Match Parameters

EFFECT OF CONVERSION EFFICIENCY

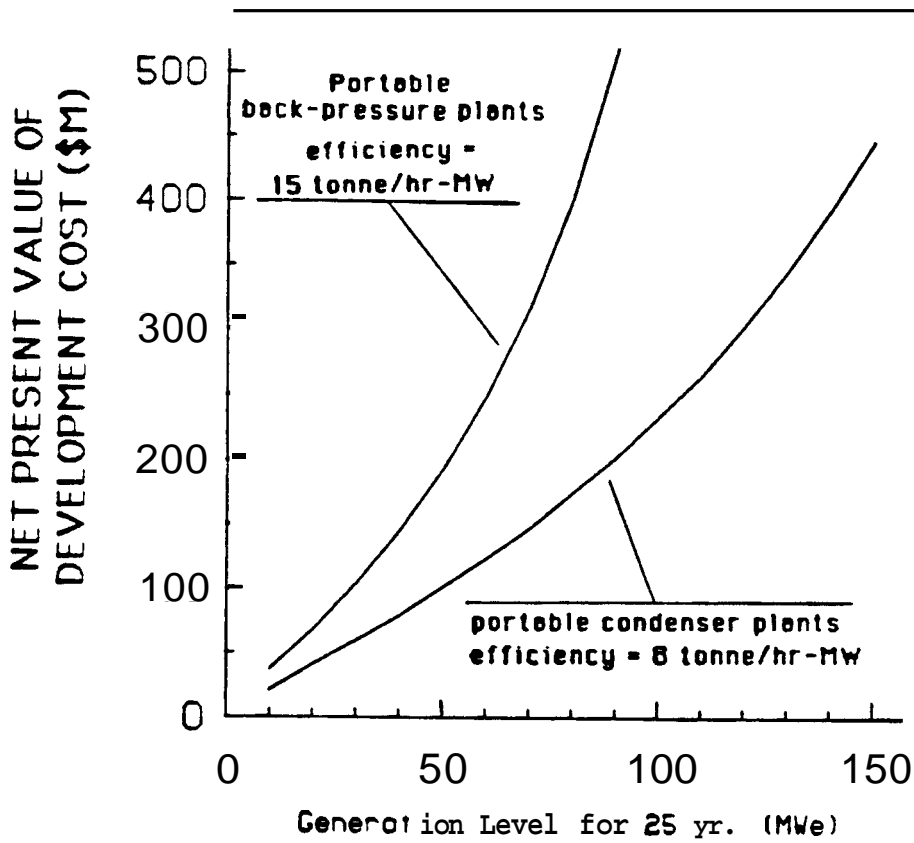

Figure 33 Effect of Conversion Efficiency Difference - Between Condenser and Backpressure Wellhead Units - on Development Cost

EFFECT OF CONSTANT RATE PRODUCTION WITH AHUACHAPAN MATCH PARAMETERS

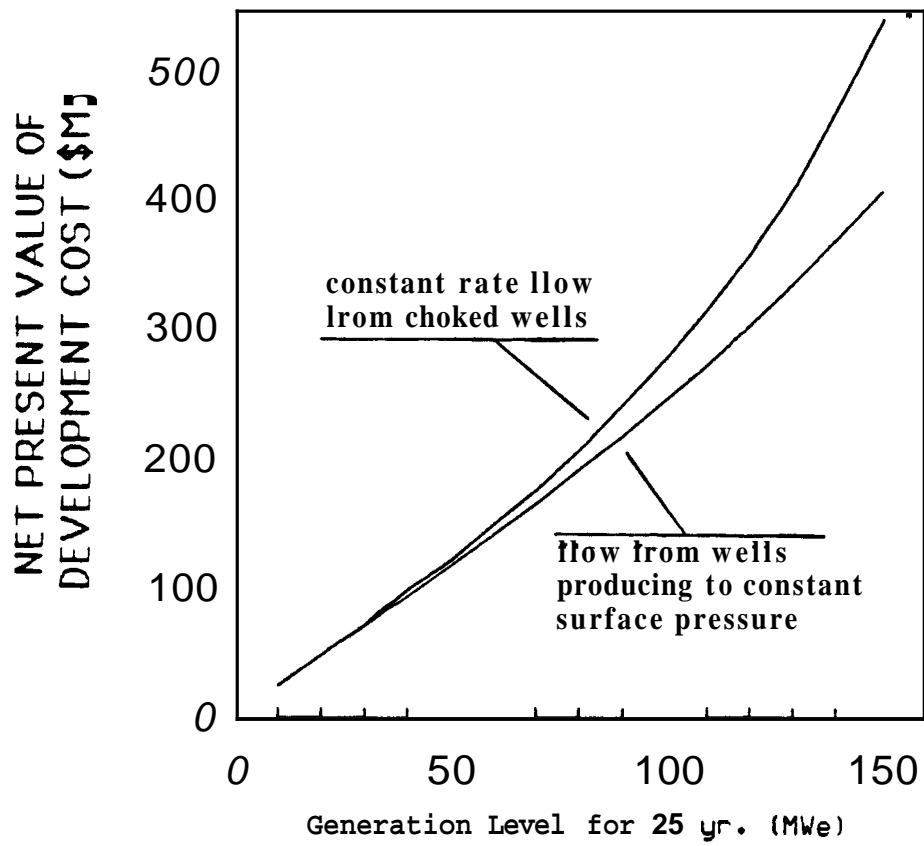

Figure 34 Effect of Constant Rate Production on Development Cost with Ahuachapan Match Parameters

EFFECT OF CONSTANT RATE PRODUCTION WITH WAIRAKEI MATCH PARAMETERS

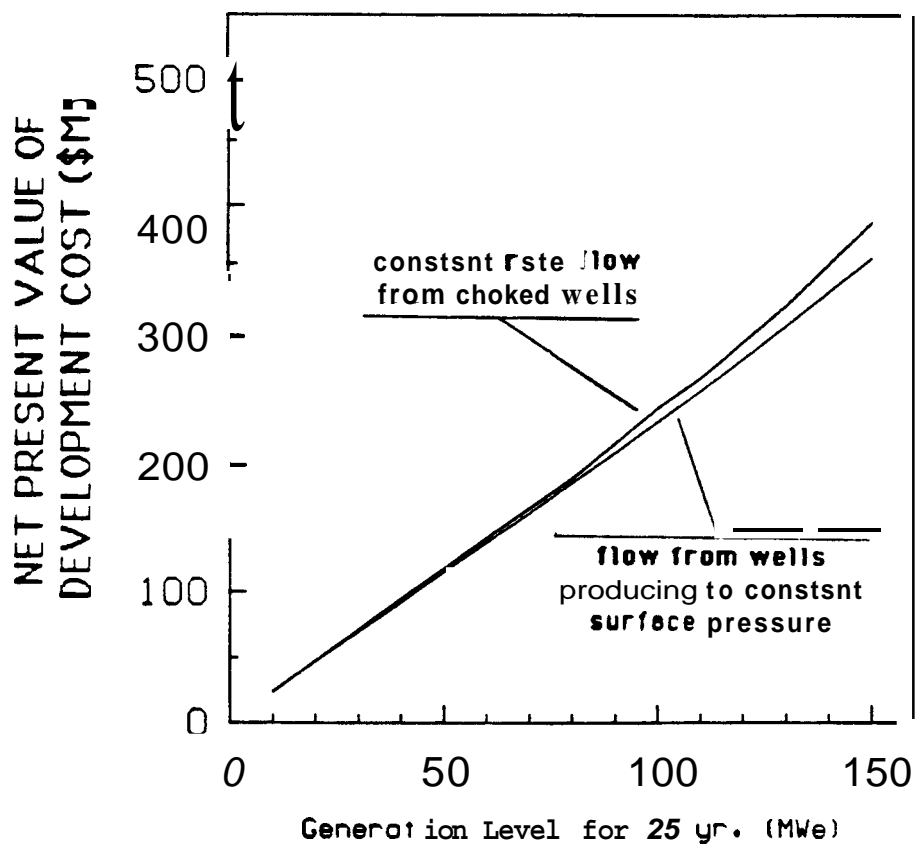

Figure 35 Effect of Constant Rate Production on Development Cost with Wairakei Match Parameters

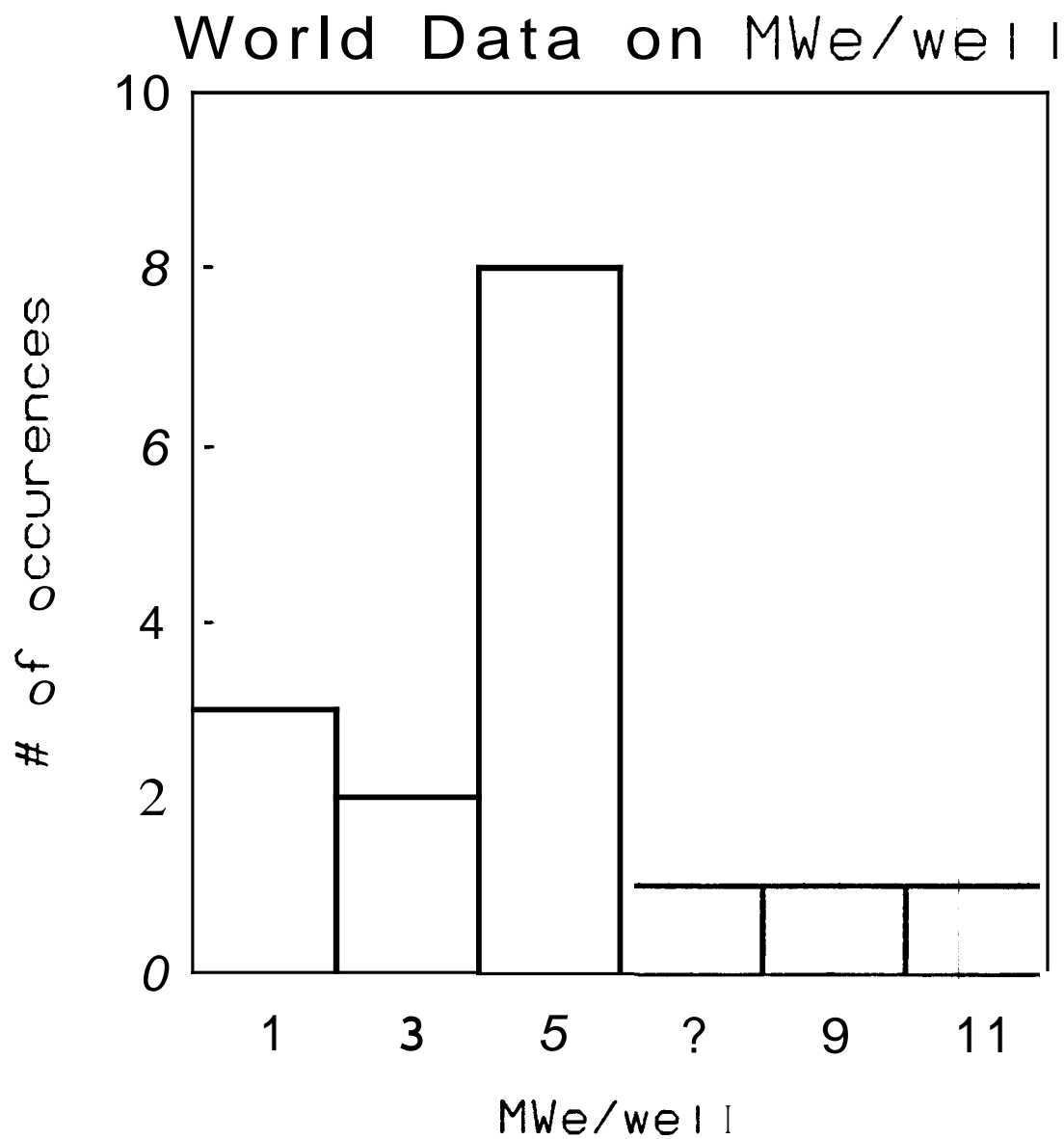

Figure 36 Histogram of World Data on MWe per Well

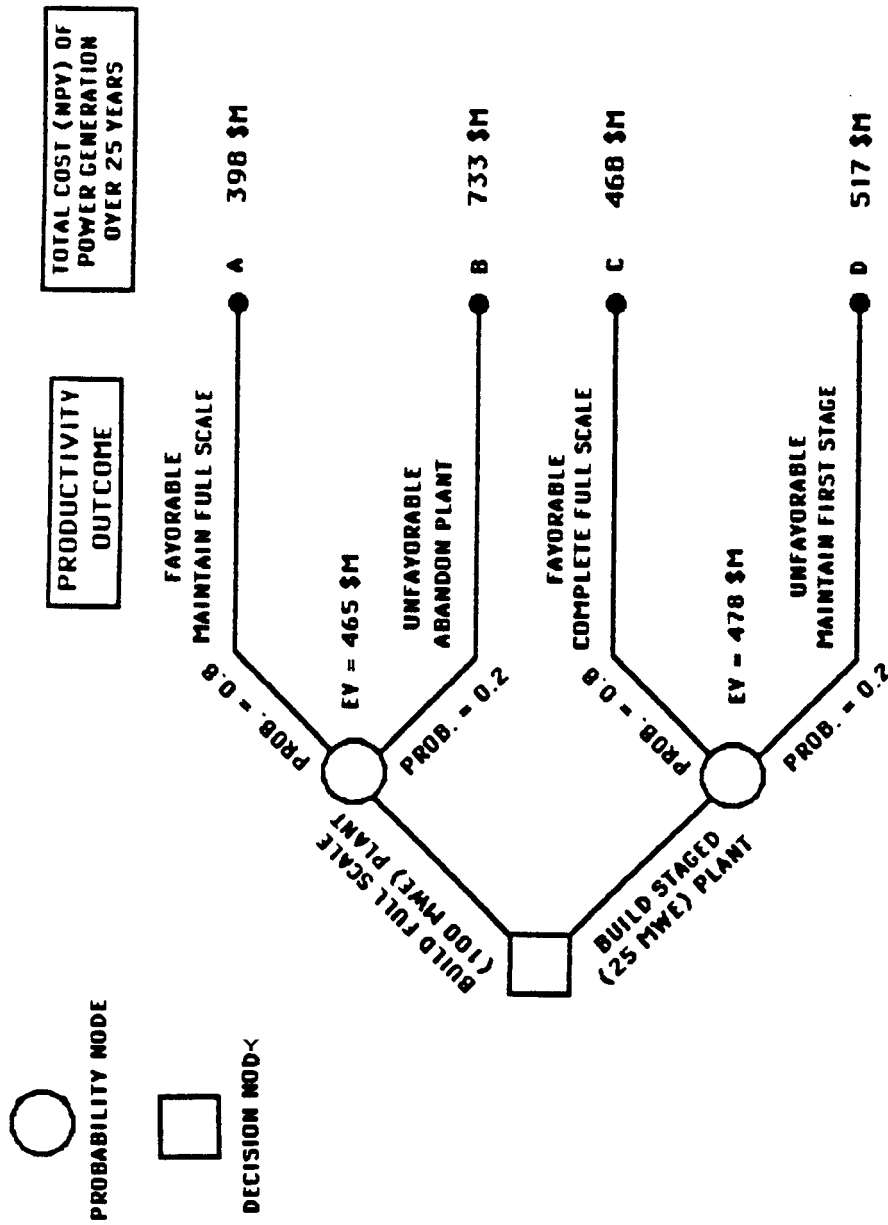

Figure 37 Decision Tree for Example of Risk Analysis in Geothermal Development

APPENDIX A: Program Hursgraphrad, Input File and Output File

```
C
C
C
C
C
C      hursgraphrad
C
C
C use this program to generate graphing files of calculated and
C measured drawdown. before running this program you should
C have selected the values of the three parameters
C named below using the hurhradfit.f program.
C
C this program queries the user for three constants describing
C a radial geothermal reservoir. the constants are TC,
C which converts time to dimensionless time, sigma,
C which is  $(2*caq*rhoa)/(cres*rhores)$ , and K
C called slope by the program, which
C is the least-square-fit slope found from running hurhradfit.
C it reads production history from an input file named "t.q.dh".
C using the three parameters it calculates the expected
C pressure response.
C the hurst simplified radial model, used here, considers
C recharge, aquifer and reservoir compressibility, and
C radial geometry. the solution is considered simplified
C since compressibility is treated as a constant.
C
C input:
C
C the production history of the reservoir is read
C from an external file called "t.q.dh" which stands for
C time (days).q (rate - kg/sec).delta h (m). delta h
C represents the actual measured drawdown. the input file has
C the following format. the first line contains an integer
C equal to the number of data points to follow. (if more
C than 125 points are to be used you must re-dimension
C the variables in the main program).
C on each line after that, starting with t=q=dh=0,
C the first column has the time (days)
C since beginning of production.
C the next column has the production rate (kg/sec)
C during the interval from the previous
C time. the last column contains the measured drawdown
C in meters. the numbers are real and columns are
C separated by blanks. if actual drawdown is not available
C then dummy values must be substituted in the file.
C
C in addition. the following items are requested by the
C program before execution:
C
C      1) tc =  $86400*k/phi*mu*c*(r**2)$  (1/days)
C
C      2) sigma =  $2*caq*rhoa/(cres*rhores)$ 
C
C      3) slope = least-square-fit slope from hurhradfit.f
C
C other variables used in the program:
C
C      1) sum = hurst summation
C
C      2) cum = cumulative mass produced (kg).
C
C      3) t,q,dh = as described above.
C
C      4) dtd = increment of dimensionless time.
C
C      5) 1 = number of data points in file t.q.dh
```



```
C
C
C          7) dhc - calculated drawdown (m)
C
C output:
C
C the output is to
C a file called "graph.dhc". It contains the value of dh,
C and dhc, versus cum. mass produced. It is headed by the
C number of points to make it suitable for graphing.
C
C *****
C
C          main program
C
C *****
C
C Implicit real*8(a-h,o-z)
C dimension t(125),q(125),dh(125),sum(125),dhc(125),cum(125)
C open (unit=3,file='t.q.dh',status='old')
C rewind (unit=3)
C open (unit=2,file='graph.dhc',status='new')
C rewind (unit=2)
C
C ***** input data *****
C
C
C read (3,*) 1
C read (3,*) (t(i),q(i),dh(i),i=1,1)
C write (6,*) ' '
C write (6,*) ' '
C write (6,*) 'what is the value of tc (1/days)?'
C read (5,*) tc
C write (6,*) ' '
C write (6,*) ' '
C write (6,*) 'what is the value of sigma?'
C read (5,*) sig
C write (6,*) ' '
C write (6,*) ' '
C write (6,*) 'what is the slope?'
C read (5,*) slope
C
C ***** initialize and laplace solution *****
C
C do 200 i=1,1
C   if (i.eq.1) then
C     n=10
C     m=150
C     sum(1)=0.0
C     dhc(1)=0.0
C     cum(1)=0.0
C   else
C     do 100 j=2,i
C       dtd=tc*(t(i)-t(j-1))
C       sum(i)=sum(i)+(q(j)-q(j-1))*s g*s gman(dtd,n,m,sig)
150       continue
C     cum(i)= cum(i-1) + (q(i)*(t(i)-t(i-1)) *60 *60.*24.)
C   end if
250 continue
C
C ***** calculate drawdown *****
C
C do 300 i=1,1
```

```

          dhc(i)=slope*sum(i)
300  continue
C
C
C          ***** write to file "graph.dhc" *****
C
C          ***** first write the calculated drawdown *****
C
          write (2,*) 1
          do 400 i=1,1
            write (2,*) cum(i),dhc(i)
400  continue
C
C          ***** now write the actual drawdown *****
C
          write (2,*) 1
          do 500 i=1,1
            write (2,*) cum(i),dh(i)
500  continue
          stop
          end
          *****
C
C
C          function sigman
C
C          (stehfest alg.)
C
C          *****
C
          function sigman(dtd,n,m,sig)
          Implicit real*8 (a-h,o-z)
          dimension g(50),v(50),h(25)
C
          if the array v(i) was computed before. the program
          goes directly to the end of the subroutine to calculate
          f(s).
          if (n.eq.m) go to 17
          m=n
          dlogtw=0.6931471805599
          nh=n/2
C
          the factorials of 1 to n are calculated into array g.
          g(1)=1
          do 1 i=2,n
            g(i)=g(i-1)*i
1
          continue
C
          terms with k only are calculated into array h.
          h(1)=2./g(nh-1)
          do 6 i=2,nh
            fi=i
            if(i-nh) 4,5,6
4          h(i)=fi**nh*g(2*i)/(g(nh-i)*g(i)*g(i-1))
            go to 6
5          h(i)=fi**nh*g(2*i)/(g(i)*g(i-1))
6          continue
C
          the terms (-1)**nh+1 are calculated.
          first the term for i=1
          sn=2*(nh-nh/2*2)-1
C
          the rest of the sn's arecalculated in the main routine.
C
C
C
```

```
c      the array v(i) is calculated.
do 7 i=1,n
c
c      first set v(i)=0
v(i)=0.
c
c      the limits for k are established.
c      the lower limit is k1=integ((i+1/2))
k1=(i+1)/2
c
c      the upper limit is k2=min(i,n/2)
k2=i
if (k2-nh) 8,8,9
k2=nh
c
c      the summation term in v(i) is calculated.
8 do 10 k=k1,k2
if (2*k-i) 12,13,12
if (i-k) 11,14,11
12 v(i)=v(i)+h(k)/(g(i-k)*g(2*k-i))
11 go to 10
13 v(i)=v(i)+h(k)/g(i-k)
go to 10
14 v(i)=v(i)+h(k)/g(2*k-i)
10 continue
c
c      the v(i) array is finally calculated by weighting
c      according to sn.
v(i)=sn*v(i)
c
c      the term sn changes its sign each iteration.
sn=-sn
7 continue
c
c      the numerical approximation is calculated.
17 sigman=0.
a=dlogtw/dtd
do 15 i=1,n
s=a*i
sigman=sigman+v(i)*sigmn1(s,i,sig)
15 continue
sigman=sigman*a
18 return
end
c
c
c      *****
c
c      function sigmn1
c
c      this is the laplace space formulation of the
c      summation from the hurst simplified radial
c      solution.
c
c      *****
c
c
c      function sigmn1(s,i,sig)
implicit real*8(a-h,o-z)
double precision mmbsk0, mmbsk1
fopt=1
rs = s**0.5
a0 = mmbsk0(fopt,rs,fer)
a1 = mmbsk1(fopt,rs,fer)
sigmn1 = a0/((s**1.5)*((sig*a1)+(rs*a0)))
return
end
```

This is a sample input file for hursgraphrad. The first line is the number of production values to be given. Each line after that contains the time in days since the start of production, the rate in kg/s, and the measured drawdown in the reservoir (for comparison with the calculated values only).

```
25
8.000000000000 8.000000000000 0.8000000880000
365.0 1184. 37.0
730. 1517. 89.2
1095. 1340. 110.9
1468. 1643. 142.7
1825. 2327. 186.0
2190. 2245. 221.7
2555. 2087. 238.3
2929. 2039. 247.2
3265. 1898. 256.1
3650. 1513. 265.0
4815. 1769. 275.2
4380. 1776. 286.7
4745. 1722. 293.1
5110. 1665. 298.2
5475. 1528. 302.0
5841. 1490. 303.3
6205. 1462. 305.8
6578. 1589. 307.1
6935. 1475. 309.6
7389. 1532. 318.9
7665. 1454. 312.2
8831. 1512. 309.6
8395. 1490. 385.8
8760. 1487. 305.8
```

This is a sample output file from hursgraphrad. It contains two data sets. Both data sets start with the number of points to follow. Each line after that contains the cumulative produced mass and the drawdown. The first data set contains the drawdown as calculated by the Hurst model. The second data set contains the actual measured values of drawdown (supplied by the input file).

```
25
0. 0.
37330624000.000 40.093300171756
05170736000.000 79.000012350002
127436976000.00 104.05539631739
179250624000.00 134.47154097336
252634096808.00 101.80557015954
323433216000.00 215.76947256252
389248848000.00 230.50391272144
455136270400.00 257.53915442434
513269654405.00 268.75647123868
560903622480.08 267.23650345356
616770806400.00 277.39606092529
672770742400.00 206.49366527399
727063734400.00 292.95702453923
779591174408.00 297.39156434704
027770102400.08 297.40934541205
874766822400.00 297.66049215326
920812454400.00 297.00379031727
960460270400.08 300.51485765444
1014975878400.0 301.99570272977
1063209030400.0 305.70504565711
1109142374400.0 306.56585732050
1156624006400.0 309.09173910709
1203013446400.0 312.16961960305
1250707478408.0 314.41332539209

25
0. 0.
37338624000.000 37.000000000808
85170736088.088 09.200000000005
127436976000.00 110.900000000008
179250624000.00 142.700000000000
252634896000.00 106.050000000088
323433216000.00 221.700000000000
389248848080.08 230.300000000000
455136270400.00 247.200000000000
513269654400.00 256.180000000008
560983622400.00 265.500000000008
616770006400.08 275.200000000008
672770742400.00 286.700000000000
727003734400.00 293.150000000000
779591174400.80 298.200000000000
027770102400.80 302.000000000000
074766022400.00 303.300000000000
920072454450.00 305.850050000000
960460270400.00 307.150000000000
1014975070400.0 309.600000000000
1063209030400.0 310.900000500000
1109142374400.0 312.250000000000
1156024006400.0 309.600000000000
1203013446400.0 305.808000000000
1250707470400.0 305.850000000000
```



```

C
C      6) 1 - number of data points in file t.q.dh
C
C      7) dp - calculated pressure drop (pa)
C
C      8) dhc - calculated drawdown (m) = dp/(rhoaq*g)
C
C output:
C
C the output is to the standard output (screen) and
C a file called "graph.fit". it contains the value of sigma
C and standard deviation for that run. the user must append
C each new data point to a graphing file, if so desired.
C
C *****
C
C          main program
C
C *****
C
C implicit real*8(a-h,o-z)
C dimension t(125),q(125),dh(125),sum(125),dhc(125)
C open (unit=3,file='t.q.dh',status='old')
C rewind (unit=3)
C open (unit=2,file='graph.fit',status='old')
C rewind (unit=2)
C
C ***** input data *****
C
C
C read (3,*) 1
C read (3,*) (t(i),q(i),dh i),i=1,1)
C write (6,*) ' '
C write (6,*) ' '
C write (6,*) 'what is the value of tc (1/days)?'
C read (5,*) tc
C write (6,*) ' '
C write (6,*) ' '
C write (6,*) 'what is the value of sigma?'
C read (5,*) sig
C
C ***** initialize and laplace solution *****
C
C do 200 i=1,1
C   if (i.eq.1) then
C     n=10
C     m=150
C     sum(1)=0.0
C     dhc(1)=0.0
C   else
C     do 100 j=2,1
C       dtd=tc*(t(i)-t(j-1))
C       sum(i)=sum(i)+(q(j)-q(j-1))*sig*sigman(dtd,n,m,sig)
100   continue
C     endif
200   continue
C
C ***** perform least square fit *****
C
C ***** (constrained through the origin) *****
C
C xy = 0.0
C sum2x=0.0

```

```
do 500 i=1,1
  xy = xy + sum(i)*dh(i)
  sum2x = sum2x + (sum(i)**2)
500 continue
slope = xy / sum2x
C
C
C ***** calculate drawdown *****
C
do 300 i=1,1
  dhc(i)=slope*sum(i)
300 continue
C
C
C ***** calculate standard deviation *****
C
devsum=0.0
do 600 i=1,1
  dy2=((dh(i)-dhc(i))**2)
  devsum=devsum+dy2
600 continue
sd=sqrt(devsum/float(1-1))
C
C
C ***** write to file "graph.fit" and screen *****
C
write (6,*) ' '
write (6,*)          sigma          standard dev.
a time constant      slope'
write (6,*) sig. sd. tc, slope
write (2,*) sig, sd
stop
end
C *****
C
C          function sigmaN
C          (stehfest alg.)
C *****
function sigman(dtd,n,m,sig)
implicit real*8 (a-h,o-z)
dimension g(50),v(50),h(25)
C
C          if the array v(i) was computed before, the program
C          goes directly to the end of the subroutine to calculate
C          f(s).
if (n.eq.m) go to 17
m=n
dlogtw=0.6931471805599
nh=n/2
C
C          the factorials of 1 to n are calculated into array g.
g(1)=1
do 1 i=2,n
g(i)=g(i-1)*i
continue
1
C
C          terms with k only are calculated into array h.
h(1)=2./g(nh-1)
```