

HIERARCHICAL DIAGNOSIS & PROGNOSIS STRATEGY FOR ELECTRICAL POWER GENERATION AND STORAGE SYSTEM

Linda Bologna

Center for Automotive Research
The Ohio State University
(on leave from Politecnico di Milano)

Ivo Guerini

Center for Automotive Research
The Ohio State University
(on leave from Politecnico di Milano)

Simona Onori

Center for Automotive Research
The Ohio State University
onori.1@osu.edu

Giorgio Rizzoni

Center for Automotive Research and
Department of Mechanical
Engineering
The Ohio State University
rizzoni.1@osu.edu

Mutasim A. Salman

General Motors
Electrical & Controls Integration
Lab
mutasim.a.salman@gm.com

Frank Zhang

General Motors
Electrical & Controls Integration Lab
xiaodong.zhang@wright.edu
(Currently with
Wright State University)

ABSTRACT

This paper presents a hierarchical approach to fault detection and isolation (FDI) of an automotive electrical power generation and storage (EPGS) system. In particular, this work focuses on a fault diagnosis strategy for the alternator and belt of the EPGS system. The proposed approach is able to detect and isolate the faults of the following components: the voltage regulator, the diodes and the belt. Preliminary evaluation results using an EPGS system test bench have shown the effectiveness of the algorithm.

NOMENCLATURE

V_f	Alternator field voltage	[V]
V_{ref}	Alternator reference voltage	[V]
V_{dc}	Alternator voltage	[V]
I_{dc}	Alternator current	[A]
I_{load}	load current	[A]
ω_{eng}	engine speed	[rad/sec]
ω_{alt}	alternator speed	[rad/sec]
n_{alt}	alternator rotational speed	[rev/min]
n_{eng}	engine rotational speed	[rev/min]

INTRODUCTION

The demand for electrical power in automotive industry has increased substantially in the last decade due to the addition of many electrical and electronic devices so as to satisfy customer needs. As a consequence of this growth in power requirements and

to maintain vehicle dependability and reparability, attention must be given to the design of effective fault diagnosis algorithms for the vehicle electrical power generation and storage (EPGS) system. The EPGS system consists of several subsystems, as shown in Figure 1. The aim of this paper is to present a novel strategy to detect and isolate faults in two critical components of the EPGS system: The alternator and the belt. Recently, Scacchioli et al. reported a model-based Fault Detection and Isolation (FDI) approach based on the concept of analytical redundancy [1]. The approach of [1] consists of comparing the values of measured variables with estimates of the same variables analytically computed by the model. The differences between measurements and estimates are used to generate residual sequences that can be used to diagnose specific faults. The implementation of this model-based approach requires that certain variables be measured, and in particular requires two independent measurements of alternator and battery currents. Hence, the load current can be calculated and used as an input to the diagnosis model. However, in most production vehicles today, only one current measurement is available, typically, at the battery, and an alternative solution must be sought for this restricted sensor set. This paper proposes a novel fault diagnosis strategy, based on a top-down approach and on the understanding of the spectral content of the available signals under various types of faults. The algorithms used in this approach are not based on an explicit model of the system, but they rely upon a physical explanation of the fault processes. Further, the solution thus developed is amenable to real time implementation. This paper focuses on the

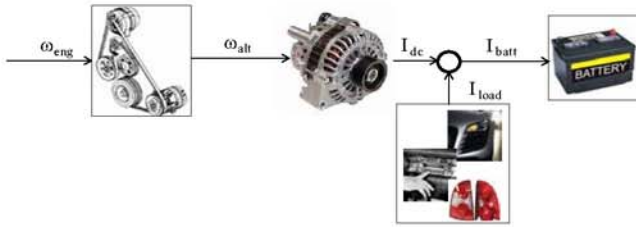

FIGURE 1. EPGS SYSTEM.

This paper focuses on the diagnosis of the following faults associated with the alternator/belt subsystems:

- Voltage regulator fault
- Open-circuit diode in rectifier fault
- Belt slip fault: Both critical slip and non-critical slip.

The nature of each of these faults is explained in the next section.

SYSTEM DESCRIPTION

As shown in Figure 1, the EPGS system includes a belt, an alternator with a rectifier, a voltage regulator, and a battery. A schematic representation of the EPGS electrical system is shown in FIGURE 2. When the engine is running, the alternator, driven by the engine through a belt, supplies power to the loads and charges a 12-V lead-acid battery. The battery provides the high power needed by the engine starter motor, and supplies power when the engine is not running or when the demand for electrical power exceeds the output power of the alternator [2].

Since the diagnostic problem focuses on detection and isolation of a specific set of alternator faults and belt slip fault, only a description of the alternator and belt component of the EPGS will be given.

Alternator

A typically automotive alternator uses a claw-pole construction [2] and includes the following subsystems:

- *Excitation Field*, which produces a field current to excite the three-phase synchronous generator.
- *AC 3-Phase Synchronous Generator*.
- *Three-phase Passive Bridge Rectifier*.
- *Voltage Regulator*, providing reference voltage control.

The AC voltage generated by the alternator is rectified through a three-phase bridge rectifier. The dc output voltage, V_{dc} , is regulated to the reference voltage V_{ref} (around 14.4 V at room temperature of 22° C) by a closed-loop regulator that acts on the field voltage V_f .

The rectified voltage V_{dc} has a residual AC component, called ripple, [2], whose frequency, f_{ripple} , depends linearly on the alternator rotational speed n_{alt} [rev/min]. For a 12 pole alternator, this relationship is given by:

$$f_{ripple} = 0.6 \cdot n_{alt} = 0.6 \cdot \text{pulley_ratio} \cdot n_{eng} \quad (1)$$

Eq. (1) describes the nominal ripple frequency that will be measured when the alternator is working properly. The value of the pulley ratio is 2.9 for the system considered in this paper, and n_{eng} is the engine speed [rev/min].

The alternator dc output voltage is maintained constant by varying the field voltage of the excitation circuit, V_f , through a switching voltage regulator that applies a Pulse-Width-Modulated (PWM) voltage to the rotor circuit.

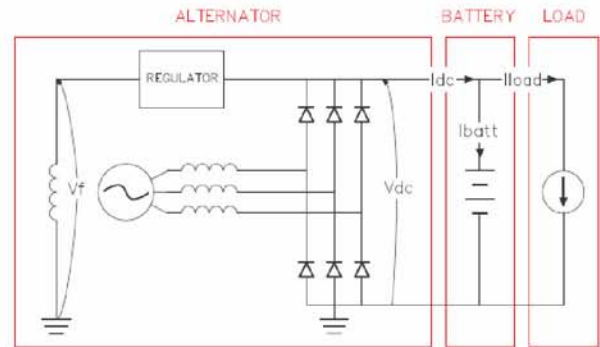

FIGURE 2. EPGS BLOCK DIAGRAM

Belt

The belt connects the engine to the alternator, and allows the transfer of mechanical power from the engine to the electrical machine. For our purpose, the automotive power transmission can be simplified and modeled as shown in Figure 4, where we consider a flat belt wrapped around two pulleys. Ideally, the pulley ratio, which is the ratio between the alternator rotational speed and the engine rotational speed, is equal to the inverse of the torque ratio, as reported in Eq. (2), so that the power is transferred from the engine to the alternator without losses

$$\frac{T_1}{T_2} = \frac{\omega_2}{\omega_1} = \frac{r_1}{r_2} \quad (2)$$

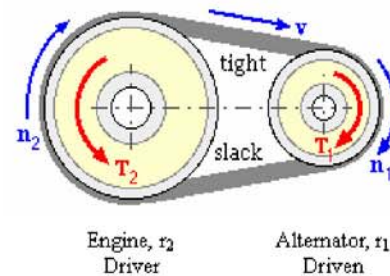

FIGURE 3. POWER TRANSMISSION MODEL.

In modern vehicles, serpentine belts power several accessories, such as the water pump, A/C compressor, and power steering pump, in addition to the alternator. Thus, a belt malfunction can affect other critical vehicle subsystems, and there are additional benefits to the prognosis of a belt failure.

Sensors

We consider the following measured signals: the engine rotational speed ω_{eng} , estimated alternator voltage V_{dc} that is based on battery voltage, the field voltage V_f , and the battery current I_{batt} . No

sensors for measuring the alternator current I_{dc} and the load current I_{load} are assumed to be present.

FAULT DIAGNOSIS STRATEGY: A HIERARCHICAL APPROACH

The main assumption made to develop an FDI strategy in this work is that the battery is not subjected to faults. As described in the introduction, since the model-based FDI solution in [1] is not feasible due to the fact that only one current measurement is available, a different approach of fault diagnosis must be pursued.

To this aim, it is useful to observe that the frequency contents of the measured signals contain useful information for fault diagnosis. In fact, a robust FDI algorithm can be developed based on a good understanding of the physics of the system and signal analysis methods. Specifically, from an accurate analysis of the signals, one can extract crucial information about the symptoms of the faults. For instance, it is known that, if an open diode fault occurs, the ripple amplitude increases.

Hierarchical diagnostic strategy refers to a top-down methodology that uses a-priori knowledge of the system signal behavior in order to detect possible system malfunctions. This allows us to go from more general information of the system malfunctions to a detailed knowledge of the fault, hence achieving fault isolation. The main idea is that, starting from a high level analysis of the signals, the occurrence of a possible fault is detected and isolated by analyzing the frequency content of the signals. An important advantage of such a hierarchical approach is that the computation load is greatly reduced when compared to a model-based FDI algorithm.

Faults under study

In this paper, we focus on typical faults related to the alternator and the driving belt. Specifically, the faults we aim to diagnose are:

- **Open diode fault:** a diode of the passive rectifier is open.
- **Regulator electronic circuit fault:** the electronic circuit of the regulator can break. In this case the field voltage goes to zero ($V_f = 0$).
- **V_{ref} too low/high fault:** the regulator can set a wrong reference voltage V_{ref} , in this case the reference voltage V_{ref} differs from the nominal reference voltage V_{ref_nom} .
- **Non critical belt slip fault:** the belt can have a slip that the regulator can compensate.
- **Critical belt slip fault:** the belt can break or can have a slip that the regulator cannot compensate.

The first three faults are different failure modes of the alternator, whereas the last two are faults related to the belt.

Frequency Analysis of the Signals

To analyze the frequency contents of the available signals, a frequency analysis approach is used.

Figures 5 - 7 depict the frequency spectrum of the alternator voltage V_{dc} , the battery current I_{batt} , and the field voltage V_f . The

corresponding data were obtained from an experimental EPGS test bench¹ under normal operating condition (i.e., in the absence of faults). The input variables ω_{eng} and I_{load} of EPGS set to 1450 rpm and 20A, respectively.

Figure 4 shows that the frequency components of the alternator voltage V_{dc} are mainly due to the power line frequency signal (60 Hz), and to the ripple (~2500 Hz) generated by the rectifier.

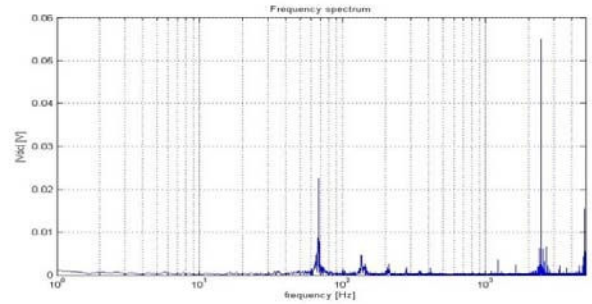

FIGURE 4. ALTERNATOR VOLTAGE FREQUENCY SPECTRUM

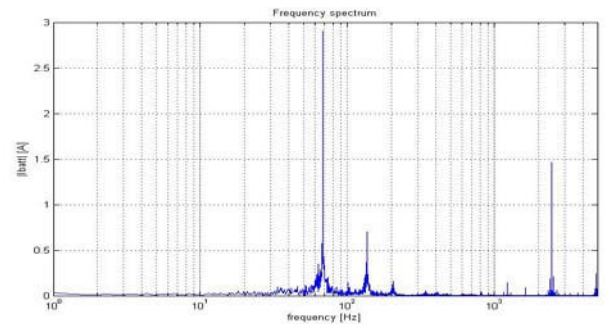

FIGURE 5. BATTERY CURRENT FREQUENCY SPECTRUM

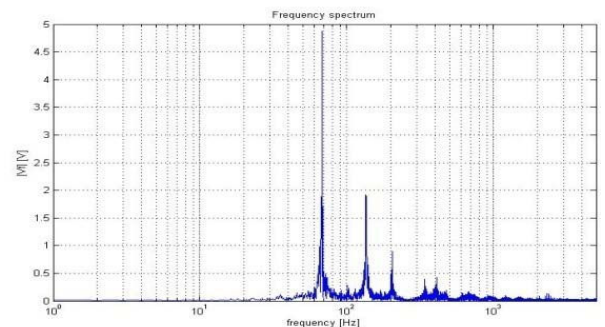

FIGURE 6. FIELD VOLTAGE FREQUENCY SPECTRUM

The frequency components of the battery current are shown in Figure 5. The spectrum of the field voltage V_f (which a PWM signal) is in Figure 6.

¹ The test bench is physically located at the Energy Storage lab of Center for Automotive Research, Ohio State University.

The following signals, in no-fault and faulty conditions, are analyzed:

- The mean value of the alternator voltage V_{dc_mean} ,
- The battery current ripple I_{batt_ripple} and
- The field voltage mean value V_f_mean .

A QUALITATIVE ANALYSIS OF THE SIGNAL BEHAVIOURS

In this section we will analyze the signals considered in the previous section, both in faulty and no fault conditions. Signal characteristics under each condition are as follows:

1. No fault condition. When the system is working properly the ripple frequency of I_{batt} is a function of the rotational engine speed, the ripple amplitude of I_{batt} is lower than a predefined maximum value, and the mean value of V_{dc} , which is the same as the nominal reference voltage, is nearly constant.
2. Open diode fault. When a diode of the rectifier opens, the ripple frequency of the alternator voltage V_{dc} decreases whereas the ripple amplitude of the alternator voltage increases. The same effects can be noticed also on the ripple of the battery current.
3. Non-critical belt slip fault. The ripple frequency of the alternator voltage is a function of the engine angular speed and of the pulley ratio as shown in Eq. (1). When a non-critical belt slip occurs, the alternator still supplies current to the load but the ripple frequency of the alternator voltage V_{dc} (and so the one of the battery current) is lower than its nominal value, because of the apparent change in the pulley ratio. This fault is considered non-critical because the alternator still maintains its voltage at the reference value.
4. Critical belt slip fault. When the regulator cannot compensate for the slip anymore, a critical belt slip occurs. In this case the alternator cannot supply the entire required load current and therefore the value of the alternator voltage drops and the battery starts discharging. The regulator tries to compensate for this fault by saturating its control variable (the field voltage V_f). Since the alternator is auto-excited the saturated field voltage is equal to the current alternator voltage, so that: $V_f = V_{dc}$. It can be noted that the “critical state” of the belt slip depends on three variables: the slip percentage, the angular velocity of the engine, and the load current.
5. Regulator electronic circuit fault. If the electronic circuit of the regulator breaks, V_f drops to 0 and the alternator stops working. The only difference between this fault and the critical belt slip is that in this case the value of the field voltage is zero instead of being saturated.

6. V_{ref} too low/high fault. When the regulator sets an incorrect reference voltage, the alternator voltage follows this wrong reference, and its mean value becomes higher or lower than the nominal one.

This qualitative analysis of the signals behavior allows us to group faults that have common effects on the system. This would give some insight into the design of a hierarchical algorithm. The results obtained from this qualitative analysis are summarized in Table 1, where:

- A_{ripple_max} is the maximum ripple amplitude in nominal conditions, which will be experimentally determined.
- f_{ripple_nom} is the nominal ripple frequency, which can be calculated through the Eq. (1).
- V_{dc_nom} is the nominal value of the alternator voltage, which is the same of the nominal reference voltage V_{ref_nom} .

FAULT	A_{ripple}	f_{ripple}	V_{dc_mean}	V_f_mean
No fault	$< A_{ripple_max}$	$\sim f_{ripple_nom}$	$\sim V_{dc_nom}$	> 0
Open diode	$> A_{ripple_max}$	$< f_{ripple_nom}$	$\sim V_{dc_nom}$	> 0
Non critical belt slip	$< A_{ripple_max}$	$< f_{ripple_nom}$	$\sim V_{dc_nom}$	> 0
Critical belt slip	$< A_{ripple_max}$	$< f_{ripple_nom}$	$< V_{dc_nom}$	$\sim V_{dc}$
Regulator electronic circuit fault	$< A_{ripple_max}$	$\ll f_{ripple_nom}$	$< V_{dc_nom}$	$= 0$
V_{ref} too low/high	$< A_{ripple_max}$	$\sim f_{ripple_nom}$	$\neq V_{dc_nom}$	> 0

TABLE 1. QUALITATIVE ANALYSIS SCHEME

Note that each fault condition has a different effect on the measured signals, and thus a different signature. By appropriately combining this information, it is possible to design a signal knowledge based algorithm which can detect and isolate each of the faults under consideration.

HIERARCHICAL DIAGNOSIS ALGORITHM

For developing a diagnostic algorithm, the qualitative analysis carried out in the previous section will be expressed in the form of rules based on the commands: IF <condition> THEN <conclusion>.

For instance, IF an electronic regulator circuit fault occurs and the regulator stops working, THEN the field voltage V_f drops to zero,

the alternator does not supply the load anymore, and the battery begins discharging.

Algorithm logic

Figure 7 depicts the proposed logic for the diagnostic algorithm which runs when the alternator is running.

The diagnosis logic has a hierarchical structure. The first level analyzes both the battery current signal I_{batt} by checking amplitude and frequency of its ripple, and the V_{dc} signal by monitoring its mean value. If an anomaly is detected, with respect to the nominal condition, the algorithm activates the lower levels to isolate the fault. In Figure 7, we indicate by V_{oc_max} the maximum battery open circuit voltage ($\approx 13V$).

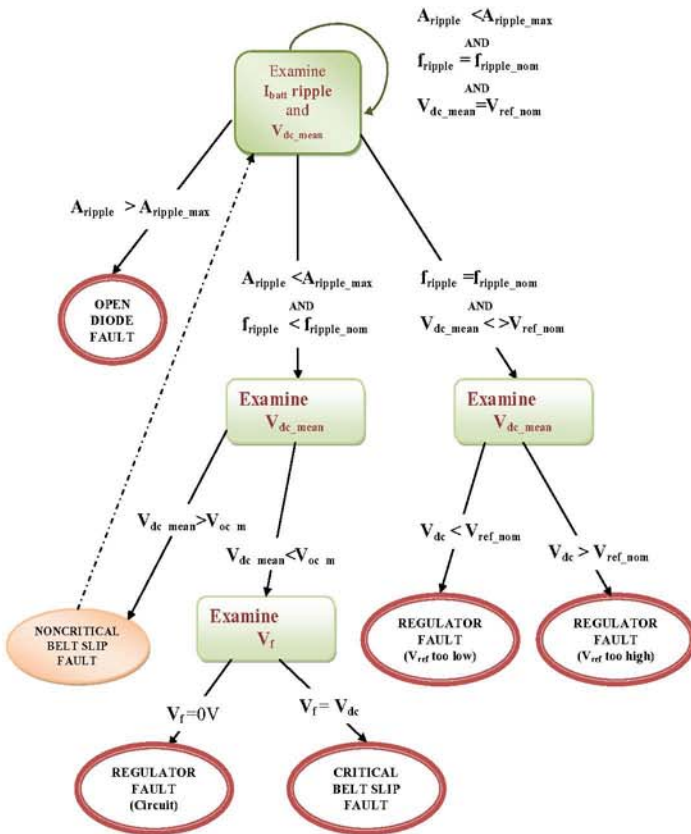

FIGURE 7. ALGORITHM LOGIC.

When the software isolates a fault, a fault indicator is set from '0' to '1' and never reset, apart from the non-critical belt slip fault indicator which is intermittent.

ALGORITHM IMPLEMENTATION

In this section, the implementation of the hierarchical FDI algorithm is described, after introducing the operating region.

The operating region

The system behaves according to the qualitative behavior summarized in Table 1, if the system inputs I_{load} and ω_{eng} are

within a predefined operating region, as depicted in Figure 8, where the load current ranges between 20A to 80A [8], and the ω_{eng} ranges from 800 rpm to 2050 rpm. The previous conditions guarantee that the system will behave as expected under no fault conditions, when the input signals, I_{load} and ω_{eng} , are within the considered range. For defining the operating region, the quantities I_{load_max} , I_{load_min} , ω_{eng_min} and ω_{eng_max} have to be defined and determined as follows.

I_{load_max} is determined considering the maximum electrical power that the installed loads could require if they are all active at the same time, and I_{load_min} can be defined considering the electrical power required by the loads which runs continuously [7]. For setting the minimum useful engine angular speed we look at the Ω - I characteristic of the alternator.

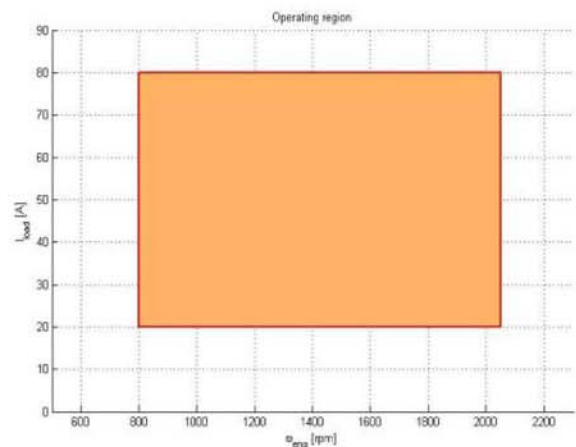

FIGURE 8. OPERATING REGION.

A qualitative example of the Ω - I characteristic is shown in Figure 9, where:

- I_{max} is the sum of I_{load_max} , the maximum current that the loads can require and I_{batt_max} . In fact, the battery is considered as a load that the alternator must supply. The battery current I_{batt_max} is estimated at 60A. So $I_{max} = I_{load_max} + I_{batt_max} = 80A + 60A = 140 A$.
- Once fixed I_{max} , Ω_{min} is the lowest angular speed at which the alternator can supply I_{max} keeping its voltage over the maximum open circuit voltage of the battery ($V_{oc_max} \sim 13V$). In other words, Ω_{min} is the lowest alternator angular speed required to maintain the battery in charge under the worst operating conditions (maximum load).

Since the value of I_{max} is determined by the installed loads and I_{load} is unknown, the only way to fix the operating region is to monitor the engine angular speed ω_{eng} . Given the minimum useful alternator speed Ω_{min} , the lowest useful engine speed ω_{eng_min} can be simply obtained by dividing this value by the pulley ratio.

- ω_{eng_max} depends on the sample rate of the Data Acquisition Board. The higher the sample rate the higher is this limit.

In our EPGs test bench the sample rate is 10 KHz, therefore, the maximum allowable frequency is the 5 KHz. The engine angular speed that results in a ripple frequency of 5 KHz can be calculated through Eq. (3):

$$\begin{aligned}\omega_{eng_max} &= \frac{f_{ripple}}{0.6 \cdot pulley_ratio} \\ &= \frac{5000Hz}{0.6 \cdot 2.9} = 2873rpm\end{aligned}\quad (3)$$

The engine speed upper limit ω_{eng_max} is then chosen equal to 2050 rpm.

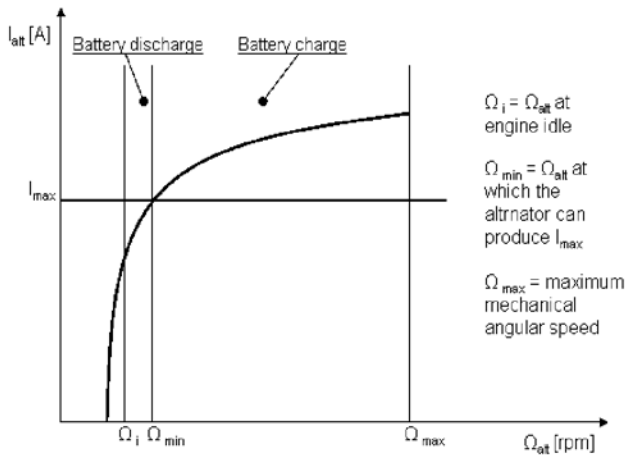

FIGURE 10. ALTERNATOR Ω - I CHARACTERISTIC.

Logic implementation

The logic is implemented using Stateflow[®] toolbox in Matlab-Simulink[®] environment. The inputs of the algorithm are as follows:

- Battery current I_{batt} for estimating the ripple frequency and monitoring the ripple amplitude;
- Engine rotational speed ω_{eng} for calculating the nominal ripple frequency f_{ripple_nom} and for checking if the system is working in the useful operating region;
- Alternator voltage V_{dc} for checking its mean value;
- Field voltage V_f checked only in the third level for isolating some faults;

Before being analyzed by the diagnostic algorithm, the field voltage signal V_f and the battery current signal I_{batt} should be conditioned. The field voltage is low-pass filtered for maintaining only its mean value by using a 2th order digital Butterworth filter with a cut off frequency of 1Hz. The battery current is band-pass filtered to retain only the useful signal component (note that the information carried by the ripple is concentrated at high frequencies as shown in Figure 5). A 5th order band-pass Butterworth filter with a low cut off frequency of 460 Hz and a high cut off frequency of 5000 Hz has been implemented. This frequency range allows both the ripple signal to be maintained and avoids aliasing.

Once extracted, the ripple frequency and amplitude from the battery current is estimated and analyzed. The ripple frequency estimation is achieved by a zero-crossing detection approach. The A_{max} threshold, experimentally fixed at 12A, allows the detection of the open diode fault, since the ripple amplitude can reach this value only under this fault condition.

The algorithm simply compares the available information with thresholds set on the basis of the nominal values, hence requiring a low computational load. Threshold setting is an essential part of the implementation and it is described in the next section.

Thresholds Calibration

Threshold calibration is an important step in the design of fault diagnosis. It is crucial to set the thresholds in a proper way such that false alarms and misdetection rate are minimized. For detecting a fault, the values of the signals analyzed at the first level of the logic are compared with their respective thresholds, determined based on the nominal values of the same signals under no-fault condition. The nominal behavior of the system is much different from its behavior in every considered fault condition.

The thresholds are chosen as follows:

- A_{ripple_max} : it is experimentally determined and set to 12A.
- f_{nom} : it is an input-dependent threshold, which directly depends on the rotational engine speed ω_{eng} , and it can be calculated through Eq. (1).
- V_{ref_nom} : it is the nominal reference voltage.
- V_{oc_max} : it is the maximum open circuit voltage of a completely charged battery after few hours of rest.

EXPERIMENTAL VALIDATION

In this section we present the experimental results of the hierarchical diagnosis algorithm.

Motor speed and load current profiles

For testing the FDI algorithm, the motor speed and load current profiles depicted in Figure 10 are used. The tests performed are 90 seconds long, of which the first 45 seconds the system runs in no fault conditions and in the second 45 seconds the same profiles are repeated after fault injection. In the following plots, the signals are depicted in blue, and the thresholds are in red.

No fault condition

Figure 11 shows the signals analyzed at by the first level of the hierarchical logic, i.e. ripple amplitude of the battery current and frequency and the mean value of the alternator voltage. It can be observed that these signals do not cross the thresholds (except during short transients which can be dealt with using a low-pass filter), and the algorithm does not detect any faults and continues cycling in the first level.

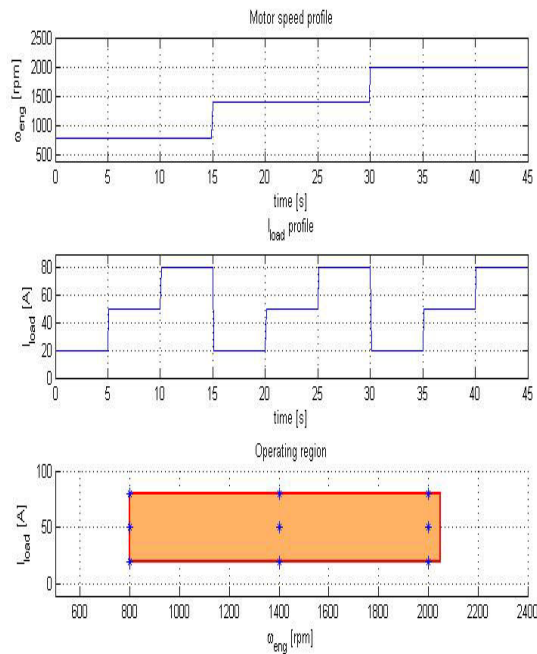

FIGURE 10. LOGIC PROFILES AND OPERATING REGION.

Open diode fault

At 45 seconds an open diode fault is injected as shown in Figure 12. When a diode breaks, the amplitude of the ripple of the battery current I_{batt} increases and crosses the A_{max} threshold (highlighted in red), and the fault indicator is set to 1 and never reset.

Belt slip faults: critical and non-critical belt slip

Figure 13 shows the behavior of the three signals under study, namely ripple frequency of the battery current, alternator voltage and field voltage, in the case that a belt slip fault is injected. The experiments has been conducting by injecting a 20% belt slip between 66 seconds and 72 seconds (the diagnostic software detects a non-critical belt slip fault), and an 80% belt slip is injected after 78 seconds. When the alternator voltage V_{dc} crosses the lower threshold, at around 82 seconds, a critical belt slip fault is detected.

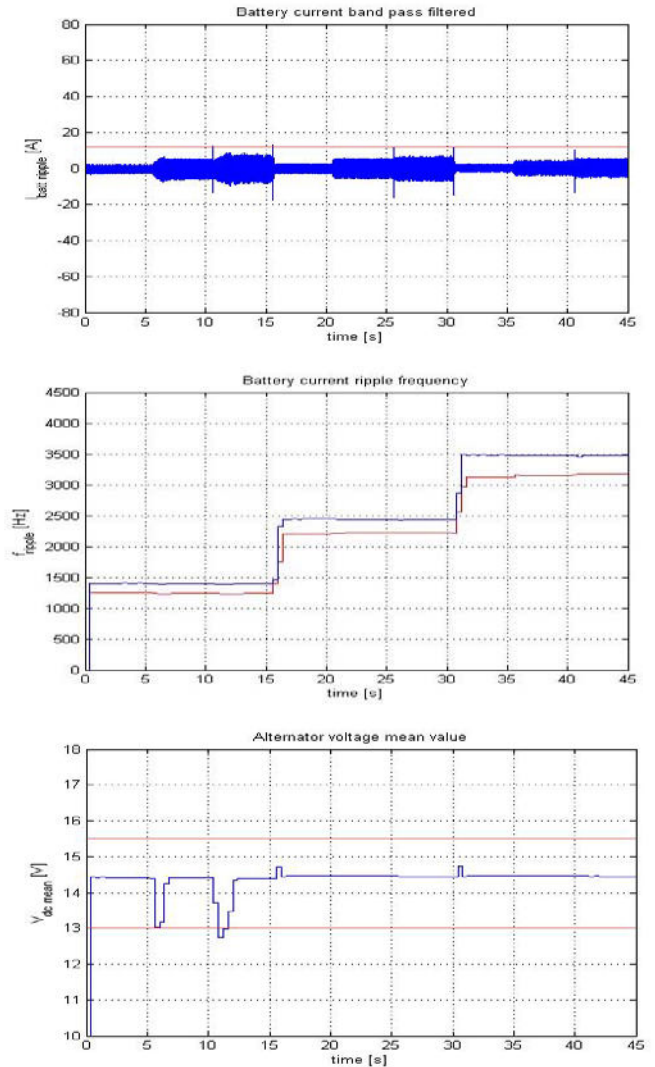

FIGURE 11. FIRST LEVEL CHECKED SIGNALS IN NO FAULT CONDITION.

The algorithm detects a non-critical belt slip fault as long as the regulator can maintain the mean value of the alternator voltage V_{dc_mean} over V_{oc_max} . In this case, only a shift in the ripple frequency value is detected and so the software generates an alarm for the non-critical belt slip fault, but then returns to the first level. When a critical belt slip is injected, the alternator voltage V_{dc} becomes lower than the maximum battery open circuit voltage V_{oc_max} , and the control variable V_f is saturated²; hence a critical belt fault is detected.

² Because of high load current and low engine rpm, the field voltage saturates.

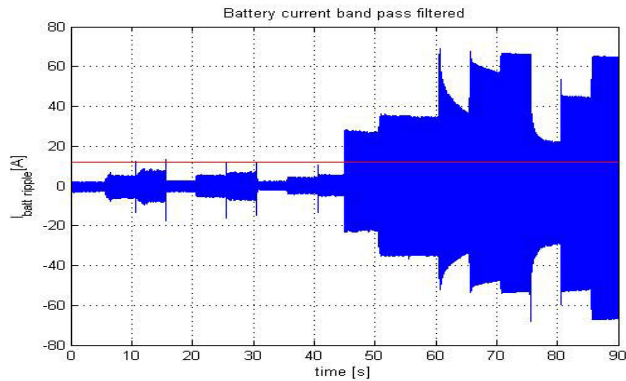

FIGURE 12. FIRST LEVEL CHECKED SIGNAL AND FAULT INDICATOR IN OPEN DIODE FAULT CONDITION.

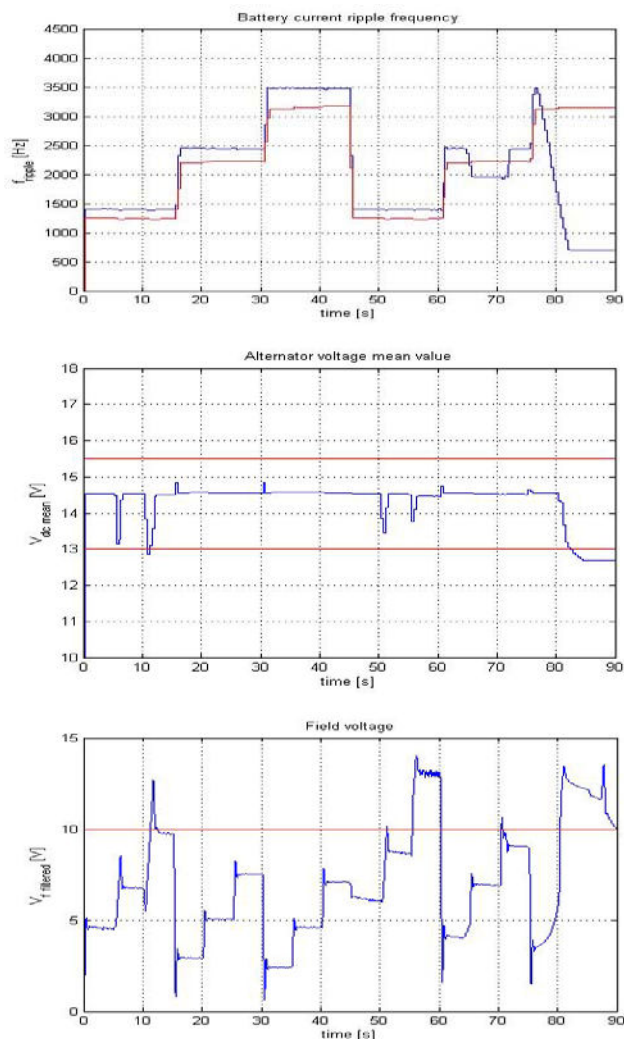

FIGURE 13. CHECKED SIGNALS IN BELT SLIP FAULT CONDITION (LOGIC PROFILES).

ACKNOWLEDGMENTS

Authors would like to thank General Motors for the financial support and technical guidance and the technical staff at CAR for their assistance with the experiments.

REFERENCES

- [1] A. Scacchioli, G. Rizzoni, P. Pisu “Hierarchical model based fault diagnosis for an electrical power generation storage automotive system”, *Proceedings of the American Control Conference*, New York City, NY, 2007.
- [2] Bosch, “Automotive electric and electronic systems”, 4th Edition, SAE Publication (2003).
- [3] M. H. Rashid, “*Power Electronics Handbook*”, Academic press, 2001.
- [4] G. Rizzoni, “*Principles and applications of electrical engineering*”, 4th edition, McGraw-Hill, 2003.
- [5] M. Stamatelatos, W. Vesely, “Fault Tree handbook with aerospace application”. NASA, 2002.
- [6] V. Venkatasubramanian, R. Rengaswamy, S. N. Kavuri and K. Yin, “Review of Process Fault Diagnosis - Part III: Process History Based Methods”, *Computers and Chemical Engineering*, 27(3), 327-346, 2003.
- [7] D. Fussel, R. Isermann, “Hierarchical motor diagnosis utilizing structural knowledge and a self-learning Neuro-Fuzzy scheme”, *Proceedings of the 24th Annual Conference of the IEEE Industrial Electronics Society, IECON 98*, Aachen, Germany.
- [8] R. Isermann, “Model based fault detection and diagnosis, Status and Applications”, in *Proc. 16th Symp. Autom. Control Aerosp.*, St. Petersburg, Russland, 2004, pp. 14–18