

Slimhole Drilling Overview for Geothermal Exploration in Indonesia: Potential and Challenges

Daniel W. Adityatama¹, Dorman Purba^{1,3}, Farhan Muhammad¹, Vicki Agustino¹, Hafni Wiharlan², Kathlyn K. Pasmeputra²

¹Rigsis Energi Indonesia, Equity Tower, 49th Floor, SCBD, Jakarta

²Universitas Pertamina, Jalan Teuku Nyak Arief, Simprug, Kebayoran Lama, Jakarta

³Enerka Bhumi Pratama, KKO Cilandak Gudang 401, Jakarta

daniel.adityatama@rigsis.com

Keywords: geothermal, drilling, exploration, Indonesia, slimhole, resource risk, cost

ABSTRACT

Unlike other energy sources for power generation such as solar and wind, geothermal energy is stored deep under the surface. Exploration activity and drilling are required to find and confirm the presence and magnitude of the resource before the feasibility of the project can be assessed. This high upfront cost in the early stage of the project while the uncertainty is still very high makes investor reluctant to invest in the geothermal exploration activity. One alternative to reduce the resource risk during exploration is by using less expensive drilling method such as slim hole drilling instead of using standard or big hole drilling. Slim hole drilling was used for early geothermal exploration in Indonesia since 1993, but the recent trend in Indonesia shows that most geothermal developers prefer to use standard or big hole instead for exploration activity. This may cause a huge loss for the developer if they are unable to confirm the geothermal resource during exploration drilling, and currently Government of Indonesia considers using slim hole drilling for reducing the resource risk in the exploration.

The objectives of this paper are to give an overview of slim hole drilling and how it differs from standard or big hole, both from technical and economic aspect. The advantages, limitation, and challenges of slim hole drilling application for geothermal exploration in Indonesia are also discussed. A case study from recent slim hole drilling in East Java is used for an example of current slim hole utilization for geothermal exploration. The lessons learned from the case study then can be used to improve exploration and drilling planning in the future.

1. INTRODUCTION

1.1. Indonesia Geothermal Target

Through Presidential Decree 22/2017 (Perpres No. 22/2017), Government of Indonesia (GoI) has set a target for 7,200 MW of geothermal installed capacity in 2025, a steep increase from the current installed capacity of around 2,100 MW (EBTKE, 2020). This target is ambitious to say the least considering current geothermal development rate in Indonesia has not been as fast as the government expect (Figure 1).

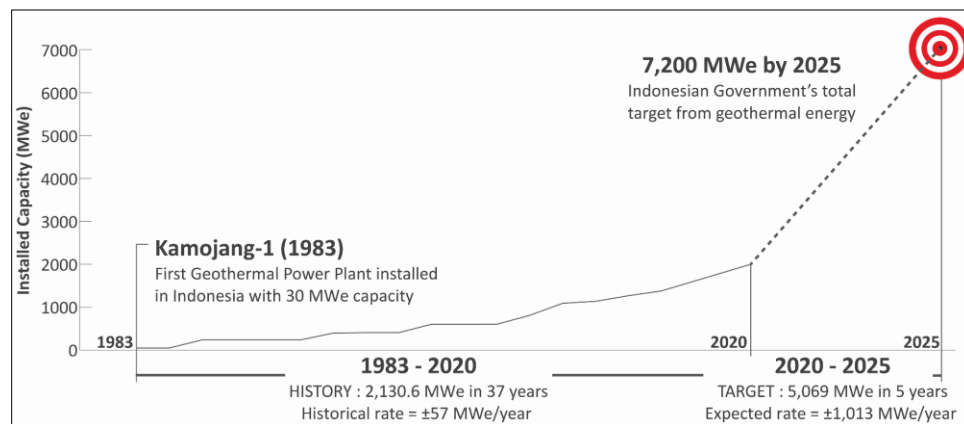

Figure 1. Indonesia geothermal power plant installed capacity and Government's target in 2025 (Modified from EBTKE, 2020).

Several studies have identified the following challenges in developing geothermal in Indonesia (Darma, 2016; Poernomo, et al., 2015):

1. Insufficient 3G (geology, geochemistry, and geophysics) data in the area renders the early assessment inaccurate.
2. Very high resource risk in the early stage of the project.
3. High upfront investment cost, especially due to the commencement of the drilling to confirm the resource.
4. Several uncertainties in legal aspects and lack of cross-sector coordination.
5. Limited number of experts with specific competences in geothermal sector.
6. Social issues such as community rejection.
7. Lack of infrastructure especially in eastern Indonesia.

Some of the aforementioned challenges are caused by the nature of the geothermal energy itself; unlike other renewable energy such as solar or wind, geothermal energy is stored beneath the surface. This requires an exploration activity first prior to proof or assess the existence or magnitude of the geothermal energy. The uncertainty of the geothermal resource existence is widely known as resource risk.

1.2. Resource Risk in Exploration Phase

Resource risk is defined as the uncertainties on the presence, extent, and the quality of the geothermal resource (Purba, Adityatama, Umam, & Muhammad, 2019). In a conventional hydrothermal system, the following aspects need to be found during exploration to be able to economically produce electricity from geothermal energy (Prasetyo, 2020):

- Adequate temperature for preferred power generation option (single / double / triple flash, binary, etc).
- Sufficient permeability to accommodate fluid flow in the reservoir.
- Benign reservoir fluid.

The lack of subsurface data prior to drilling implies that until there is an enough well data, the resource uncertainty will still high. The 3G survey conducted may not be enough to proof the reservoir quality and characteristic, thus requiring a deep well drilling activity to proof the result of 3G exploration. The exploration activity itself may contribute up to 20% of the total project cost, where the main contributor of this high cost is the exploration drilling (Direktorat Panas Bumi, 2020). This high upfront cost for exploration and exploration drilling in particular in the early phase of the project when there are no geothermal resource certainty and no means to generate revenue for a while (up to 5-7 years) is what deters investor to invest in the geothermal exploration.

This exploration resource risk is one of the major hindrance to geothermal development in Indonesia and worldwide because it can stall geothermal development project in the very early stage (ESMAP, 2016). One alternative to reduce the early capital required for exploration is by drilling smaller diameter well, or slimhole well. Drilling slimhole well in exploration is expected to reduce the cost while still be able to obtain all of the exploration objectives (Thorhallsson & Gunnsteinsson, 2012).

1.3. Objectives and Methodology

The purposes of this paper are as follow:

1. Give overview on slim hole drilling and how it may be used for geothermal exploration activity in Indonesia;
2. Overview on worldwide and Indonesia experiences on geothermal slimhole drilling for geothermal exploration;
3. Extract lessons learned from geothermal slimhole drilling in East Java, Indonesia;
4. Discuss the challenges and potential of slimhole drilling utilization for geothermal exploration in Indonesia.

The study compiles various information and experiences regarding geothermal slimhole drilling worldwide from previous publications and research. A case study from recent geothermal exploration drilling in East Java is also discussed to give perspective on the current trend and challenges of utilizing geothermal slimhole drilling in Indonesia. This study is admittedly still in the early phase. Authors welcome any feedback or question that might be useful to improve the quality of the information presented on this paper.

2. SLIM HOLE DRILLING

2.1. Definition

Currently there is no formal standard that classify wells (especially geothermal well) based on their diameter. Society of Petroleum Engineers (SPE) defines slim hole well as a well with a casing size less than 7" for 90% of its depth, while ISOR defines slim hole well as a well with a final diameter less than 6" (Thorhallsson, 2016). But the most common used definition is that any well with wellbore diameter less than 6" is considered a slimhole well (Schlumberger, 2020; Mackenzie, et al., 2017). Apart from wellbore diameter, in geothermal industry worldwide, there are three types of well commonly used for exploration based on their objectives and depth: 1) temperature gradient well, 2) deep slimhole well, 3) conventional/standard/big well (Mackenzie, et al., 2017). Table 1 summarizes the typical depth and objectives for the well configuration commonly used for geothermal exploration. The typical well schematic for slim, standard, and big hole is shown in Figure 2.

Table 1. Typical well configuration used for geothermal exploration (modified from Mackenzie et al., 2017).

Type of Well	Typical Depth	Objective(s)
Temperature gradient	200 – 800 m vertical depth Typically drilled above the reservoir	<ul style="list-style-type: none"> • Confirm the presence of clay cap • Confirm temperature • Validate the conceptual model.
Deep slimhole (Prod. Casing 2-3/4" – 7")	~500 – 2,000 m vertical depth Typically drilled through clay cap and reach reservoir	<ul style="list-style-type: none"> • Confirm adequate temperature for commercial production (primary objective) • Test productivity (secondary objective).
Conventional/Standard/Big hole (Prod. Casing 9-5/8" – 13-3/8")	~1,500 – 3,000 m vertical depth	<ul style="list-style-type: none"> • Provide comprehensive testing of resource productivity • Might be used for production or injection.

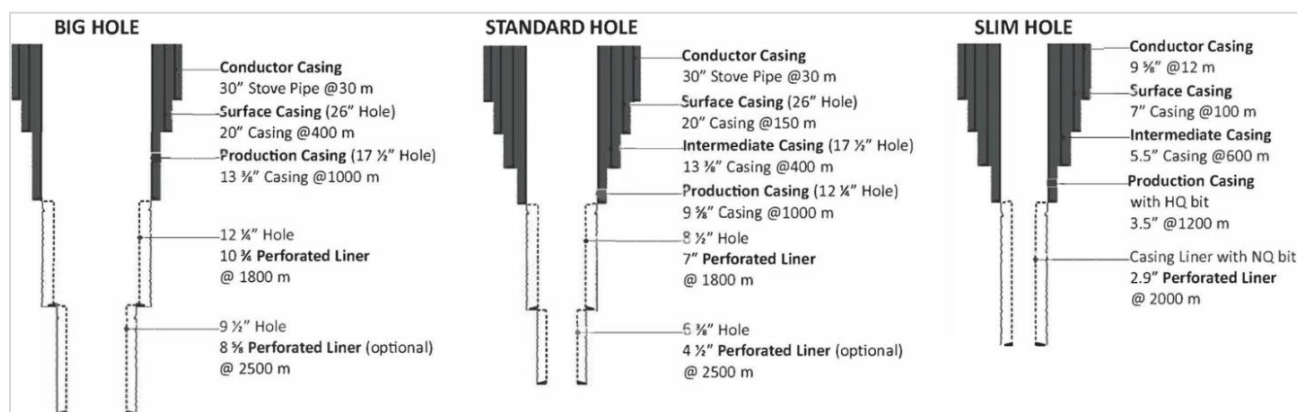

Figure 2. Common well configuration for big, standard, and slim hole (Purba et al., 2019).

2.2. Drilling Equipment

In contrast with standard or big hole well, a slim hole can be drilled with different equipment: diamond coring and rotary (Table 2). Diamond coring uses high rotation per minute (rpm) and low weight on bit (WOB) to cut through rock and produce core, while on rotary drilling the recovered samples are just rock fragments or cutting (Finger, et al., 1999). Drilling using diamond coring is less affected of loss circulation zone compared to rotary drilling, while rotary drilling is normally having higher drilling rate.

Table 2. Comparison of typical rotary drilling rig and coring drill rig for slim hole application.

Comparison(s)	Rotary Drilling Rig	Coring Drilling Rig
Rig floor Crew	5 plus toolpusher	2 or 3 with or w/o toolpusher
Mud logger	Yes	No
Mud engineer	Yes	Sometimes
Company man	Yes	Sometimes
Drill site	400 ft by 250 ft Large pits (1,200 bbl) and sump	200 ft by 150 ft or smaller Small pits (25 bbl) and sumps
Rig size	150 ft high 40 or more truck loads 30 ft high base (large BOP, flowlines) Big mud pumps (600 GPM / 3,000 psi)	60 ft high 2 to 5 loads 11 ft high base (smaller stacks) Small pumps (45 GPM / 1,100 psi)

Slim hole drilling using coring rig is commonly used in mining industry, which can drill up to 1,000 m depth, although rigs that can core up to 2,000 m are also available and can be adapted to geothermal service. As coring rig is significantly smaller in size than conventional drilling rig in oil and gas or geothermal, coring rig has mobility advantage and require smaller well pads, infrastructure, and produce less environmental disturbance. This make slim hole coring rig suitable for geothermal exploration in Indonesia where the savings in infrastructure (roads, well pad) and transportation cost can be substantial.

Another factor that should be considered is the total number of loads during rig and other equipment mobilization. The slimhole drilling require a smaller number of loads compared to standard drilling as shown in Table 3.

Table 3: Number of loads of typical rig used for geothermal drilling

Type of well	Rig type	Estimated total number of loads
Slimhole	Surface coring rig / 450 HP rig	30-40
Standard (production casing 9-5/8")	750 HP-1000 HP	60-100
Big (production casing 13-3/8")	1500 HP-2000 HP	80-140

2.3. Drilling Fluid (mud)

The purpose of drilling fluid is to remove / lift cutting to the surface, keep the hole stable, and lubricate and cool the drill bit. Diamond coring rig usually uses circulation rate of around 10 gallons per minute (GPM), while rotary drilling requires hundreds of gallons per minute (Nielson and Garg, 2016). However, using hybrid drilling strategy (combining rotary and coring) may require more than 10 GPM at some hole section.

2.4. Drilling Tubular

Diamond coring uses drilling rod with flush joints instead of drill pipe with large tool joints. The rod sizes commonly used are as follow:

- P = 4.5" x 4"
- H = 3.5" x 3.063"

- $N = 2.75'' \times 2.375''$

The annular space between the hole and the drilling rod is small, ranging from 0.25'' to 0.5'', while the inner diameter is also flush and use an open-ended bit.

2.5. Typical Well Pad Area for Slimhole Drilling

Slimhole drilling require less well pad area compared to standard/big hole well, with the most common size is around 40x40 m (Mackenzie, et al., 2017). This is smaller than the typical standard size well of around 70x100 m (in some cases might even reach ~100x100 m), which may contribute in accelerate the drilling preparation time and less cost for land acquisition and pad construction (Purba, Adityatama, Hasyimi, & Chandra, 2018; Mackenzie, et al., 2017). Figure 3 shows the typical pad layout for slimhole drilling. Please note that the rig mast height may vary depends on rig type or manufacturer. The water pond size can also vary depends the water supply infrastructure, and a sump pit may also be required if the well is about to be flow tested, as in the exploration phase generally there is no reinjection well available.

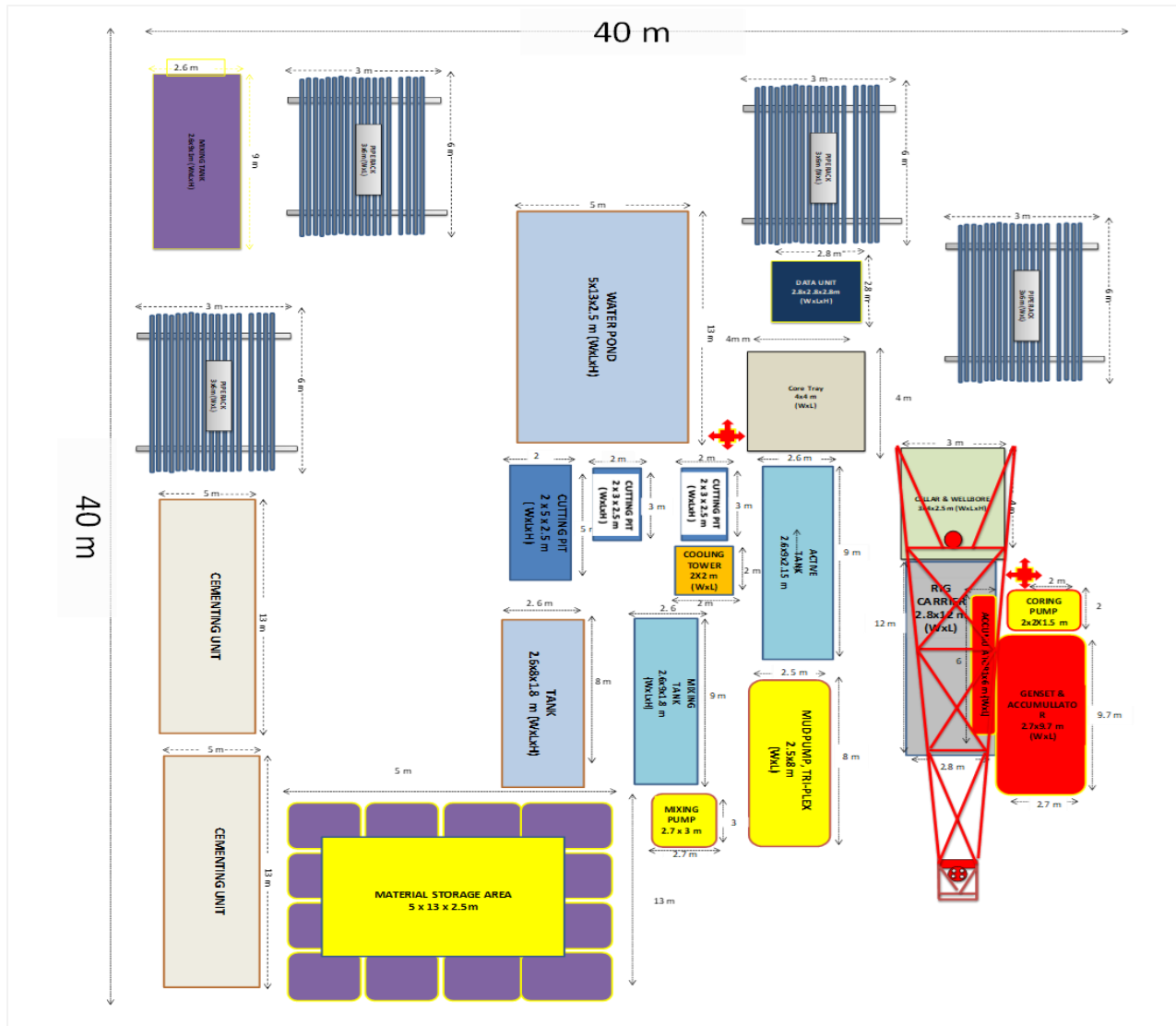

Figure 3. The typical pad layout for slimhole drilling activity.

2.6. Advantages and Drawbacks of Slimhole Drilling

Several studies in the past have compared slimhole with standard/big hole drilling in various aspects (Thorhallson & Gunnsteinnsson, 2012; Purba, Adityatama, Umam, & Muhammad, 2019; Thorhallson & Gunnsteinnsson, 2012; Mackenzie, et al., 2017) as shown in Table 4. In the absence of a standard in Indonesia regarding the definition of slimhole drilling, each geothermal company can design a slimhole well according to the needs of their respective projects. Various slimhole designs will certainly bring their own advantages and drawbacks. In this study, the discussion about slimhole drilling is put in the context of exploration phase where the uncertainty of geothermal resources is still high and the supporting infrastructures at the surface are still minimum.

Table 4. Comparison summary of slimhole with standard/bighole drilling (modified from Purba et al., 2019)

Area of Comparison	Big/Large hole	Standard/Regular hole	Slim hole	References
Typical Drilling depth	Total drilling depth may range from 1,500 - 3000 m	Total drilling depth may range from 1,500 - 3,000 m	Total drilling depth may range from 1,200 - 2330 m (2,330 meter reached by slimhole in Sarulla field, Indonesia)	Nielson and Garg, 2016; Atlas Copco, 2016; Þórhallsson, 2016; Delahunty et al., 2012; Þórhallsson, 2012; Finger et al., 1996; Finger et al., 1997; Finger and Jacobson, 2000; Gunderson et al., 2000; Mackenzie et al., 2017; Sunarso et al., 2018.
Rig capacity	May require rig with capacity of 1,000 - 2000 HP (depend on well total depth and inclination)	May require rig with capacity of 550 - 1,500 HP (depend on well total depth and inclination)	Could be drilled using rig with capacity less than 550 HP	Þórhallsson, 2016; Þórhallsson, 2012; various internal/unpublished drilling reports
Rig footprint/wellpad	Depend on the rig size, the wellpad may require area around 10,000 - 15,000 m ² (useable area)	Depend on the rig size, the wellpad may require area around 7,500 - 12,000 m ² (useable area)	Due to more compact and simple rig, commonly wellpad required much smaller, around 2,000 - 4,000 m ² (useable area)	Þórhallsson, 2016; White and Hole, 2015; Sunarso et al., 2018; Mackenzie et al., 2017; various internal/unpublished drilling reports
Drilling preparation time	Might require longer time to prepare access road, laydown area and wellpad due to bigger size, compare to smaller rig	Might require longer time to prepare access road, laydown area and wellpad due to bigger size, compare to smaller rig	Shorter preparation time compare to bigger rig due to compact size and less number of rig equipment	Þórhallsson, 2016; White and Hole, 2015; various internal/unpublished drilling reports
Rig mobilization time	Rig mobilization time took longer than smaller rig due to number and size of the loads (with the similar mobilization distance)	Rig mobilization time took longer than smaller rig due to number and size of the loads (with the similar mobilization distance)	Shorter mobilization time compare to bigger rig due to compact size and less number of rig equipment	Þórhallsson, 2016; various internal/unpublished drilling reports
Water supply requirement	Depend on the hole size, may ranging from 60-95 litre/second (maximum requirement usually occurred in the reservoir zone with total lost circulation / blind drilling situation)	Depend on the hole size, may ranging from 60-95 litre/second (maximum requirement usually occurred in the reservoir zone with total lost circulation / blind drilling situation)	Less water supply required, may ranging from 5-30 litre/second (water requirement in rotary mode is higher than coring)	Þórhallsson, 2016; White and Hole, 2015; Mackenzie et al., 2017; various internal/unpublished drilling reports
Casing and cementing materials	Casing required is around 200 tons Cement volume required is $\pm 84 \text{ m}^3$	Casing required is around 135 tons Cement volume required is $\pm 55 \text{ m}^3$	Casing required is around 80 tons Cement volume required is $\pm 26 \text{ m}^3$	Þórhallsson, 2016
Logging tool pass	Able to pass all kind of logging tool	Able to pass all kind of logging tool	Most logging tools are either 35 mm or 42-44 mm in diameter which still good for slimholes, except for CBL probe with 70 mm diameter.	Þórhallsson, 2016
Lithology definition	Using drilling cuttings as the media to determine lithology, alteration mineralogy and fracture characteristics. Note that during total loss circulation there will be no cutting return to surface.	Using drilling cuttings as the media to determine lithology, alteration mineralogy and fracture characteristics. Note that during total loss circulation there will be no cutting return to surface.	Using core sample as the media to determine lithology, alteration mineralogy and fracture characteristics (core sample give better definition than cuttings)	Finger and Jacobson, 2000; White, 2015
Directional drilling ability	Able to accommodate directional drilling technology to deviate the well	Able to accommodate directional drilling technology to deviate the well	Commonly drilled vertically. More difficult to be drilled directionally compare to big or standard well type	Þórhallsson, 2016; various internal/unpublished drilling reports
Discharge capability	Representative to possible actual discharge capacity. Might give greater output than standard well due to its large diameter casing	Representative to possible actual discharge capacity	Require further study to assess its discharge characteristic to actual production well size	Finger et al., 1996; Finger et al., 1997; Nielson and Garg, 2016; Þórhallsson, 2016; White, 2015
Production/ Injection/ Monitoring Capability	Able to serve as production or injection well when reservoir characteristic allows. May serve as monitoring well.	Able to serve as production or injection well when reservoir characteristic allows. May serve as monitoring well.	May be difficult to induce flow and it may be too low to serve later as production wells. May serve as monitoring well.	Nielson and Garg, 2016; Þórhallsson, 2012; White, 2015
Estimated drilling days	Ranging from 30 - 45 days (from spud to rig release with 2,000 meters total depth)	Ranging from 30 - 45 days (from spud to rig release with 2,000 meters total depth)	Ranging from 60 - 120 days (from spud to rig release with 2,000 meters total depth)	Finger et al., 1996; Finger et al., 1997; Þórhallsson, 2012; Delahunty et al., 2012; Sunarso et al., 2018; Mackenzie et al., 2017; various internal/unpublished drilling reports
Estimated total cost per meter (US\$/m)	US\$ 3,000 - 4,500 / meter (include rig and all drilling support cost)	US\$ 2,000 - 4,000 / meter (include rig and all drilling support cost)	US\$ 400 - 1,000 / meter (include rig and all drilling support cost)	Finger and Jacobson, 2000; Nielson and Garg, 2016; Atlas Copco, 2016; Delahunty et al., 2012; various internal/unpublished drilling reports

Based on Table 4, Mackenzie, et al. (2017) and dela Pena (2018), the authors believe that several advantages and disadvantages of slimhole drilling utilization for geothermal exploration project in Indonesia need to be discussed in more detail (Table 5).

Table 5. Identified advantages and disadvantages of slimhole drilling for geothermal in general.

Advantages	Disadvantages
Relatively lower cost alternative to confirm the geothermal resource, as it is proven to be able to drill deep enough to reach reservoir (can be up to 2,000 m)	Generally not used as production/reinjection well due to small wellbore diameter.
Less infrastructure (access road, well pad, etc.) is required, thus may speed up the total exploration duration.	Slower drilling rate.
Greater geologic detail obtained due to the full coring at reservoir.	Difficult to drill deviated/directional well.
With proper well design, might provide same measurement / testing information provided by standard/big hole well.	Limited logging tools due to smaller wellbore diameter at reservoir.
Lower cost of failure and can be used to de-risk future full size drilling.	

3. WORLDWIDE GEOTHERMAL SLIMHOLE DRILLING EXPERIENCE

Mackenzie, et al., (2017) has summarized slimhole drilling experiences from 45 geothermal projects in 14 countries (Figure 4). They found that 62% (28 fields) of the fields have slimhole well that have been flowed, while slimholes drilling in 73% (33 fields) of the fields have successfully intersected the target reservoir (Figure 5). Even though this summary does not reveal or clearly define the results of the overall exploration project, several points that could be drawn are:

1. The slimhole drilling results around the world shows that slimhole well are able to be drilled deep enough to penetrate the reservoir.
2. It is clear that more than half of the fields showing slimhole wells that flowed, thus keeping the possibilities open for conducting flow test to assess the productivity of the field.

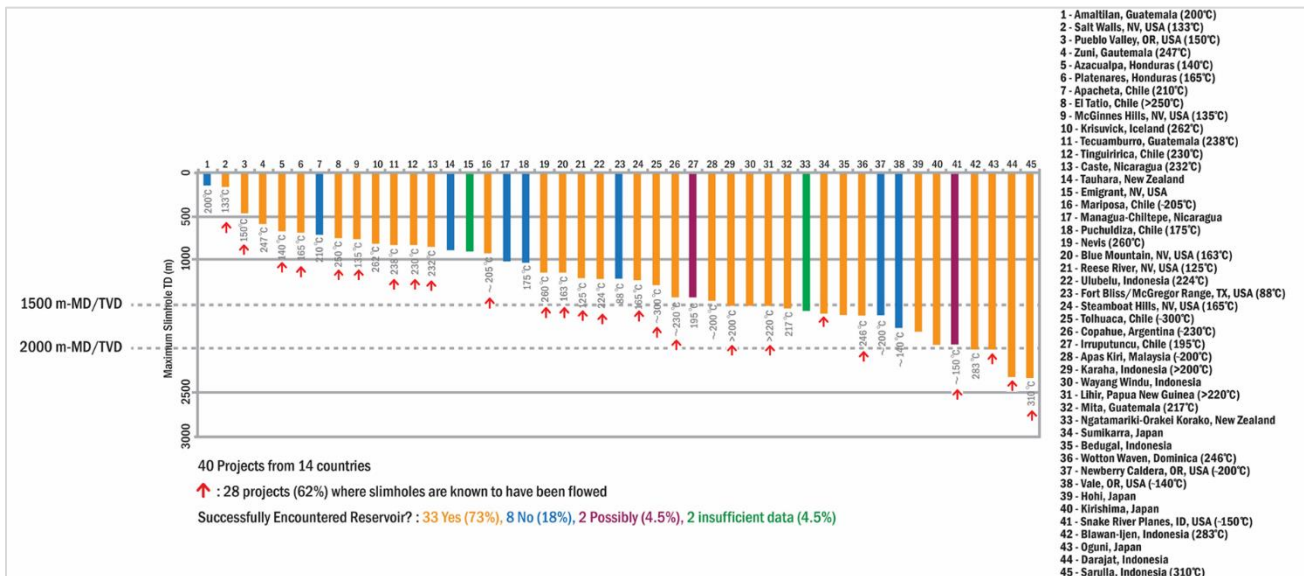

Figure 4. Geothermal fields from 14 countries which utilized slimhole drilling. The chart shows the maximum depth of slimhole well drilled, while the red arrow shows where the slimhole well has been flowed (Mackenzie, et al., 2017).

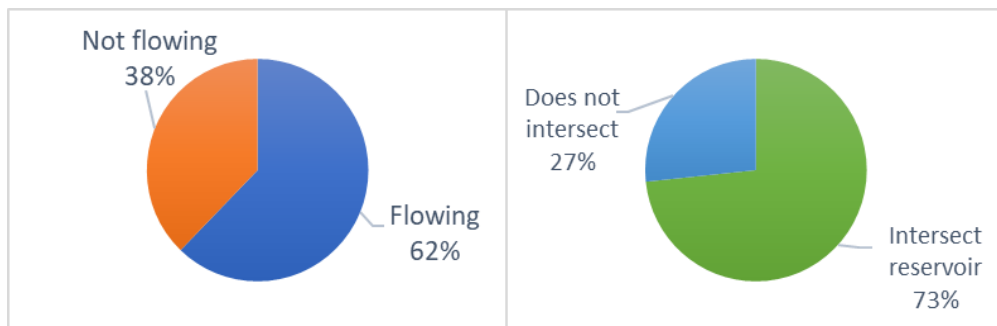

Figure 5. Exploration drilling result from 45 geothermal fields around the world.

4. CASE STUDY

As shown in Figure 4, there were a lot of geothermal slimhole drilling for exploration in the past in Indonesia (Mackenzie, et al., 2017). Yet, until recently the preference for geothermal developer in Indonesia was to use standard/big hole well for exploration. The argument was that the well can be used directly to produce/reinject the steam if they find the geothermal resource (Purba, Adityatama, Umam, & Muhammad, 2019), with the risk of having a relatively high cost of failure. Before geothermal slimhole drilling in East Java in 2016, the last slimhole operation was in 1998 (Sudarman & Hochstein, 2014; Hochstein & Sudarman, 2008).

In the recent years following the funding from the Government of Indonesia, The World Bank, and the Government of New Zealand to accelerate geothermal exploration, a slimhole drilling once again become a potential alternative for conducting geothermal exploration (Apriani, Randle, & Paripurna, 2018). However, with the lack of expertise and contractors for geothermal deep slimhole, drilling a deep slimhole poses a lot of risks and challenges that can nullify the advantages of using slimhole for exploration. Therefore, a recent geothermal slimhole drilling in East Java was used as a case study to highlight the current challenges of utilizing deep slimhole for geothermal exploration in Indonesia.

4.1. Slim Hole Drilling for Geothermal Exploration in East Java

In 2016, a geothermal company in Indonesia conducted 2 (two) slim hole drilling as a part of exploration activities. The slimhole option was chosen because there were limited surface manifestation at the area, making the well targeting to find area with high temperature, high permeability, and neutral fluid difficult (Daud, et al., 2017). Slim hole well offers significant decrease of risk at lower cost compared to standard hole by reducing the exploration upfront cost while still be able to accomplish resource estimation goal.

The Well-1 is located near the center of the Kendeng caldera where the possible hydrological upflow was inferred from the results of geophysical surveys. This well was programmed to penetrate and case off the interpreted thick clay cap and reach a maximum depth of 2,000 vertical depth, where hot, neutral chloride water hypothetically exist (Sunarso, 2020; Daud, et al., 2017).

The drilling objective of the well were as follow (Sunarso, 2020):

1. Obtain core data up to 2,000 m.
2. Obtain temperature data
3. Obtain reservoir fluid data, especially pH.

The drilling rig used was a full coring rig (KWL-1600) typically used for mineral exploration.

4.1.1. Drilling Program and Casing Plan

The drilling program and casing plan summary for the Well-1 is shown on Figure 6 below.

Well Profile	Casing Design	Bit & BHA Design	Mud Design	Coring Design	BOP Installed	Logging	Cementing
12 m CONDUCTOR	CONDUCTOR 9-5/8", 47ppf, R1			DRILLING OPEN HOLE	N/A		CEMENT 0 - 12 m
100 m SURFACE	SURFACE CASING 7", 23.3 PPF, API 5CT, K55 (0 - 100 M) CEMENT CLASS G 13.5 PPG	HQ Rod Bt Sub HQ Bit - Surface Bit Open Reaming DP 4-1/2" Bt Sub 8-1/2" PDC and/or Rock Bit	FRESH WATER 5%KCL-POLYMER MW: 8.7 Visc : 34 - 45 Ph : 9.5	CORING - FULL CORING HQ DRILLING OPEN HOLE 12 - 100 M	N/A		CEMENT CLASS G 13.5 PPG 0 - 100 m
600 m INTERMDT	INTERMDT CASING 5.5" ASTM A53, Sch40 Grade B (0 - 600 M) CEMENT CLASS G 13.5 PPG	ROD HQ (100 - 600 M) Bt Sub HQ Bit - Diamond Open Reaming ROD HQ (100 - 600 M) Bt Sub 6-1/8" Bit	WBM (0 - 150 m) Native Clay+LCM MW: 8.7-9.2 Visc : 40-45 Ph : 9 HTHP POLYMER Polyamine-anti Swel	CORING - FULL CORING HQ 100 - 600 M DRILLING OPEN HOLE 100 - 600 M	BOP Installed ANNULAR 7-1/16" Double Ram 7-1/16" 3000 PSI		CEMENT CLASS G 13.5 PPG 0 - 600 m Leak Off TEST - FIT
1200 m PROD CSG	Casing Hanger PROD CSG NWT type - 3.5" (0 - 1200 M) CEMENT CLASS G 13.5 PPG	ROD HQ (600 - 1200 M) HQ Stabilizer Bt Sub Bt HQ - Diamond Open Reaming ROD HQ (600 - 1200 M) Bt Sub 4.5" Bullnose Bit	WBM (0 - 550 m) Native Clay+LCM MW: 8.7-9.2 Visc : 40-45 Ph : 9 HTHP POLYMER Polyamine-anti Swel	CORING - FULL CORING HQ 600 - 1200 M	BOP Installed ANNULAR 7-1/16" Double Ram 7-1/16" 3000 PSI Master Valve 6"		CEMENT CLASS G 13.5 PPG 0 - 1200 m
2000 m NOT SCALE	+ Casing Hanger PERF. LINER 2.9" 1200 - 2000 m	ROD NQ (1200-2000 M) NQ Stabilizer Bt Sub Bt NQ - Diamond : - UMX BIT 7 SERIES - UMX BIT 8 SERIES - UMX BIT 10 SERIES	WBM (0 - 1500 m) %6 KCL MW: 8.8 - 9.2 Visc: 45-50 Native Clay+LCM H-Visc: 55-60 HTHP POLYMER Polyamine-anti Swel	CORING : FULL CORING NQ 1200 - 2000 M	BOP Installed ANNULAR 7-1/16" Double Ram 7-1/16" 3000 PSI Master Valve 6"	Termal Logging Pressure Logging SPINNER	

Figure 6. Drilling program for Well-1 (modified from Sunarso, 2020).

The 7" surface casing section was to be drilled using pilot core with the HQ size, and then followed by enlarging the hole using 8-1/2" bit. The next 5-1/2" intermediate casing section was to be drilled by the same HQ core bit, then enlarged by 6-1/8" bit. The next sections (3-1/2" HQ and 2-7/8" NQ) was planned to be straightly drilled using HQ and NQ core bit respectively. Note that the Well-1 planning involved hole enlarging activity in the larger hole section. The reason behind this and its consequence in the drilling performance will be discussed in the later section of this study.

4.1.2. Drilling Rig Specification

Well-1 was drilled using KWL-1600 rig with specification shown in the Table 6.

Table 6. General rig specification used in Well-1

Equipment	Specification
General specification	Rig with open hole and coring drilling capacity, complete with 440 HP engine @ 1800 rpm. Equipped with top drive.
Mast & capacity	Mast total length = 12.43 m Haul winch travel = 11 m Hoisting capacity = 34,100 lbs. (15.5 ton) Hoisting speed = 1.1 m/s
Top Drive	Head traverse length = 7.5 m Retract force @5000 psi = 40,700 lbs. (18.5 ton) Pull down force = 21,206 lb. (9.6 ton)
Wireline coring	Drum capacity capable to accommodate min 2200 m with 6 mm rope. Hoisting capacity min 3,307 lbs. (1.5 ton) Hoisting speed 4 m/s
Coring pump	Max 65 gpm (264 litre/minute) with working pressure of 1500 psi.
Triplex mud pump	440 HP mud pump. Minimum pressure range 1776-3300 psi with liner size of 3" – 4-1/2" Flow rate = 200-300 gpm

4.1.3. Well-1 Pad Layout

Rig KWL-1600 only require a wellpad with dimension 40 x 60 m². This wellpad area requirement is much smaller compared to standard-sized hole that may require up to 10,000 m² wellpad due to the more complex equipment and bigger rig size. The Well-1 pad layout is shown on the Figure 7.

Mixing tanks area occupied the most space in the well pad area at around 70 m², followed by water pond area at around 65 m². The bigger the well size, the bigger also the tank and water pond required. During exploration phase, a smaller well pad area might benefit the developer for several reasons:

- Faster preparation time (land acquisition process and wellpad construction).
- Less cost for land acquisition where the uncertainty is still high.
- The smaller-sized rig is also required less additional access road modification or construction compared to the bigger rig for standard-sized hole.

One thing that should be noted is that for the Well-1 drilling, the water source for drilling is located around 17 km from the well pad, and the water is transported via tank truck instead of using water transfer pipeline.

4.1.4. Drilling Result

The drilling progress with actual casing setting depth is shown on Figure 8. The actual casing setting depth did not deviate much from the original planning in Figure 6. However, the actual drilling days to reach 2,000 m depth deviates significantly from the initial plan, which took 169 days to complete the well, far exceeds the 62 days in the planning. Table 7 shows that from around 169 days of total drilling operation, the Non-Productive Time (NPT) comprises of 17% of the total operation, with unplanned time encompasses 19% of the total drilling time. It should be noted that there is no firm standard or definition to classify the drilling time distribution. Therefore, for this case study, this paper will use the following classification to define the drilling activity:

- **Productive Time (PT)**, comprised of coring and enlarging, run-in-hole casing, cementing, and wait-on-cement (WOC) time.
- **Unplanned Time**, comprised of stuck pipe, unplanned change of bit, dealing with Total Loss Circulation (by using cementing, inserting banana trunk / sawdust, and pull out due to problem in string or coring).
- **Non-Productive Time (NPT)**, comprised of rig equipment failure and repair, waiting time for program, personnel, or equipment.

Table 7 also shows that from the total drilling duration, the hole enlarging activity using rotary drilling on 7" casing section and 5.5" casing took similar time with the pilot coring hole. This seems counterintuitive with the common practice where rotary drilling is generally much faster than full coring. The reason of this seemingly low rate of drilling was due to the insufficient mud pump capacity for rotary drilling, and the lack of water when encountered a loss circulation zone.

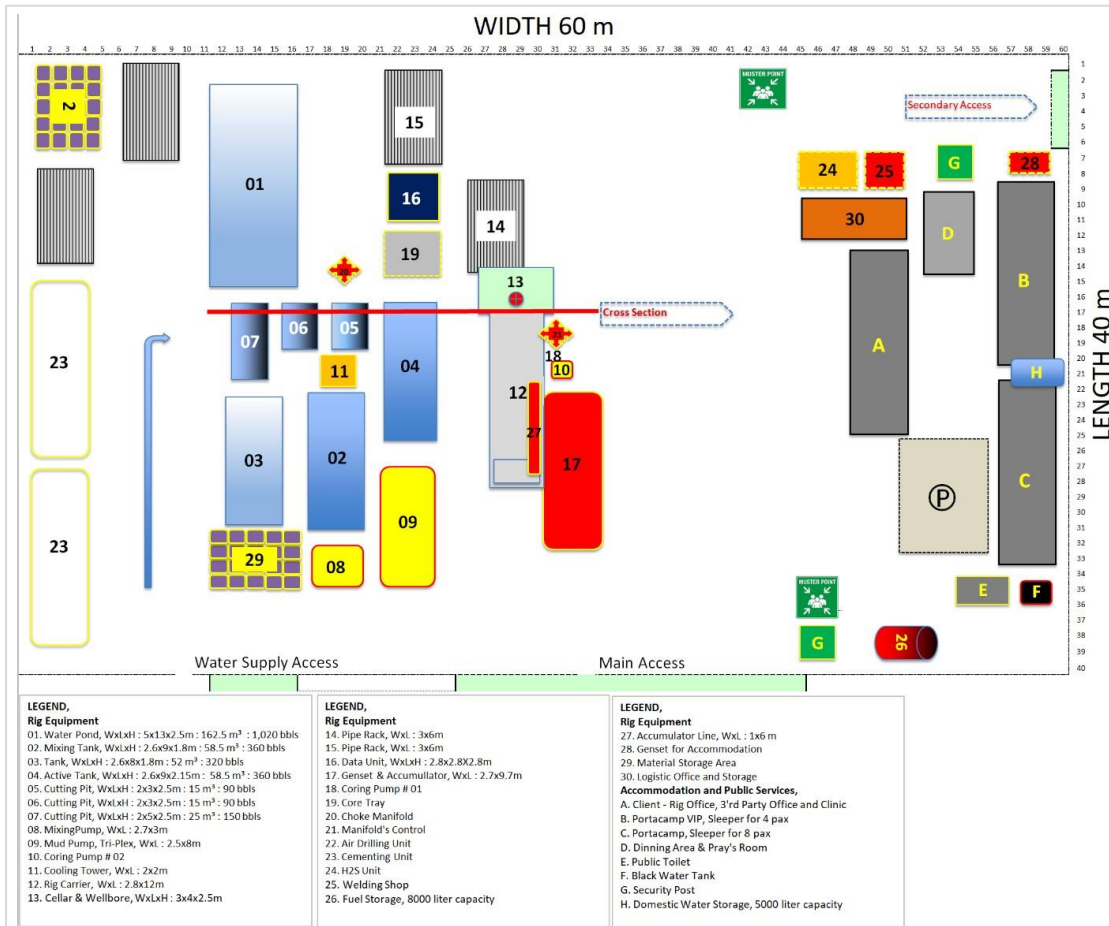

Figure 7. Well-1 pad layout (Sunarso, 2020)

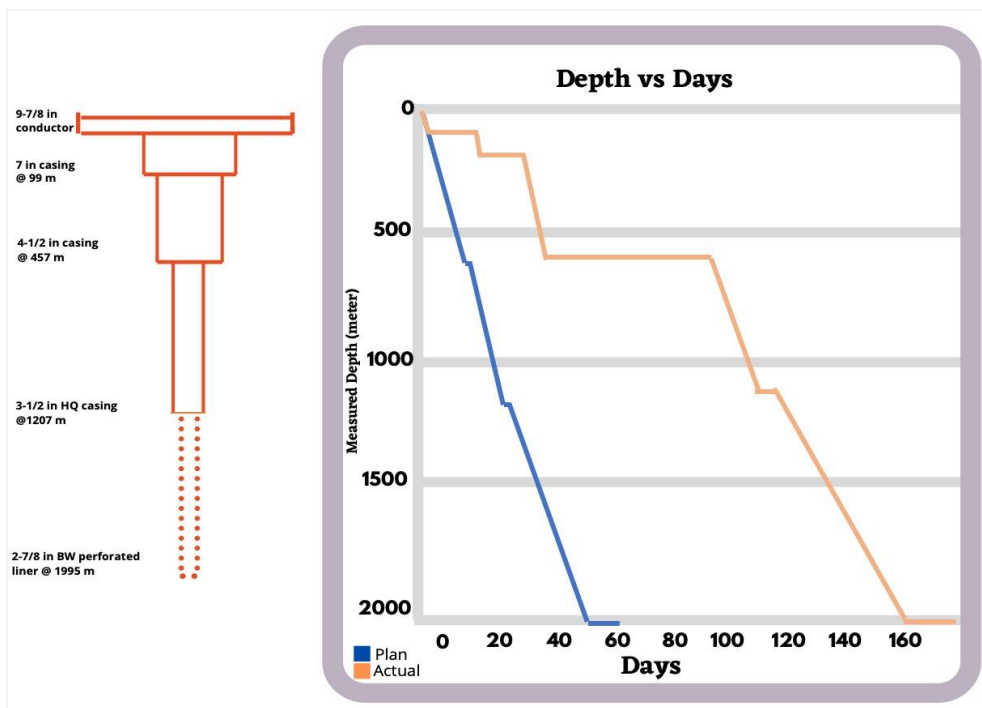
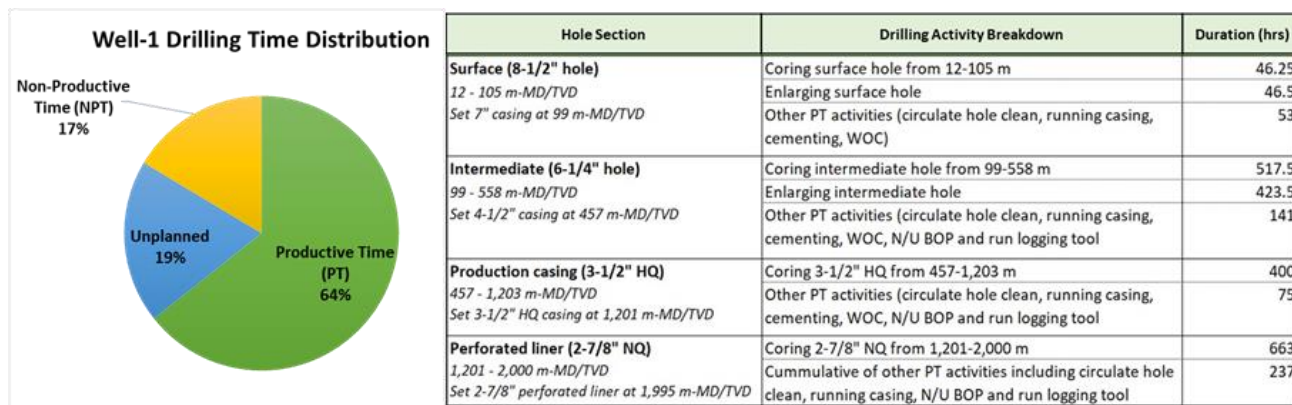

Figure 8. Time-depth curve of Well-1 drilling (modified from Sunarso, 2020).

Table 7. Operation breakdown of Well-1 drilling

4.2. Lessons Learned from Well-1 Slimhole Drilling

There were several difficulties faced by Well-1 drilling team during the operation as follow:

4.2.1. Improper Well Design and Drilling Program

Well-1 was planned to be drilled down up to 2,000 mMD TD using mainly HQ and NQ pipe, without any contingency. While the KWL-1600 is able to utilize larger PQ pipe and core bit (4.8" bit OD) up to 1,000 m, but this was not the case due to the contractors did not have the PQ rod. Enlarging hole from 3.75" HQ bit to 8-1/2" and 6-1/4" was proven to be difficult and time consuming. Drilling the larger section using rotary drilling was also not possible, as the rig was not equipped with large enough mud pump and proper swivel to transport the cuttings if the drilling was conducted by rotary drilling from the beginning.

4.2.2. Equipment Compatibility with the Drilling Rig

There are some standard geothermal-required rig components that are not necessarily available in slim hole drilling rig, for example the Blow Out Preventer (BOP). As the consequences, modification or addition of supporting substructures and loading arm is required to accommodate the BOP height, due to the coring mining rig such as KWL-1600 typically does not have enough height clearance. The BOP size and type is also crucial, as the BOP size should be able to accommodate all drill rod and BHA used. Some modifications are required to make mud (or gas) flow from wellbore to surface comply with current practice used in geothermal drilling, as it is not regulated in mining industry.

The drill rod/pipe length is also problematic, as slimhole drilling use length range 1 (R1, 18-22 feet) drill pipe (DP) and drill collar (DC) which is very uncommon in Indonesia (the most common is R3 range) due to rig mast limitation. This posed a problem during drilling operation, as DP and DC handling and make up during rotary drilling was not a straight-forward process and must be assisted by a crane. This was one of the reasons why the rotary drilling rate is very slow in Well-1 case.

4.2.3. Inadequate Water Supply

The water source for Well-1 drilling was located 17 km from the Well-1 pad and transported by tank truck. This was problematic during loss circulation in particular, as when the water on the pond was depleted, the drilling stopped and only be continued after the water replenished by the tank truck. This discontinuity of the water supply was critical, not only in term of schedule, but in term of well control to prevent steam kick/blowout.

4.2.4. Personnel

The difference in industry standard and regulation means that there is a high chance for the drilling rig crews for not having required certification. The difference in standard and practice also implies that the common and critical practice in geothermal drilling is not known by drilling rig crew, for example the blow out prevention procedure, hence requires additional training to familiarize the drilling rig crew with those procedure. On top of those certifications, geothermal-experience and equipment-handling skill is something need to be considered as the key element on selecting the crews.

5. SUMMARY

5.1. Slimhole Drilling Overview

- Worldwide experience has shown that the slimhole drilling is able to confirms the existence of geothermal resource with a fraction of the cost required for standard/big well.
- Smaller and relatively simpler equipment for slimhole drilling requires less infrastructure such as access road and wellpad. This can contribute in the reduction of both of the cost and time for exploration drilling preparation.
- Overall, slimhole drilling has a potential to accelerate and de-risk the geothermal exploration phase in Indonesia, especially in an area with low confidence level or in a remote area with minimum infrastructure.

5.2. Challenges of Slimhole Drilling for Geothermal Exploration in Indonesia

Prior to slimhole drilling in East Java on 2016, the last geothermal slimhole drilling operation was on 1998, more than 20 years ago. This makes a slimhole drilling in geothermal especially challenging due to the lack of experienced personnel and or contractors. Several challenges identified in this study are:

5.2.1. Clear subsurface requirement for a proper well design process

The rig specification required should follow the drilling objectives, which are mainly dictated by the subsurface requirement. The limited directional drilling capability of slimhole coring well and the limited logging tool options should be carefully considered and taken into account in the well design process. To address those issues, the current discussion in Indonesia is to use a bigger multipurpose rig such as Epiroc Predator 250 or Bauer Prakla R-100. However, those rigs are not currently available in Indonesia, which brings us to the next challenge. And even if those multipurpose rigs are available in Indonesia, it is uncertain whether they could provide an attractive commercial proposal to the geothermal developers when facing with small scale exploration projects (less than 5 slimhole wells).

5.2.2. Limited availability of ready-to-use slimhole rig in Indonesia.

The experience on Well-1 in East Java showed that there are a lot of modification required to make the available rig and equipment commonly used in mining industry to comply with the working environment of geothermal drilling, both from technical aspects and regulation. As stated in the Section 5.2.1, currently there is no multipurpose rig readily available in Indonesia, and there is a limited surface coring rig that has been modified to operate in geothermal drilling.

Several potential approach to address this issue are as follow:

- Use the readily available rig on the global market. This means that the rig should be imported or brought into Indonesia from overseas. However, it requires a lot of capital and without enough number of wells to be drilled, it might not be attractive for the rig contractors to invest.
- Modify the existing coring rig currently in Indonesia. This can be done with a well-defined subsurface objective and a careful drilling engineering and planning to identify all modifications required. However, similar to the first option above, as most of the coring rig contractors are operating in mining industry, without sufficient number of geothermal wells to be drilled, there is very little incentive for the contractors to invest in modifying their rig.

5.2.3. Lack of experienced personnel

As most of coring rig contractors are operating in mining industry and not familiar with geothermal drilling environment, it is crucial to have the project being supervised or run by personnel with adequate geothermal drilling knowledge and experience. A proper training and certification might be required to assess and prepare the personnel involved in geothermal slimhole drilling.

With only one slimhole drilling project in the last 20 years in Indonesia, the drilling engineering expertise and know-how for geothermal slimhole drilling is very rare. Therefore, it is highly important to extract all of the lessons learned acquired by the slimhole drilling campaign in East Java in 2016.

5.2.4. Further study to evaluate the flowtest result of slimhole well

Even though slimhole wells worldwide have shown that they can be flowed, but further research should be conducted on how to make the result relevant if converted to the standard production well size.

6. CONCLUSION AND PATH FORWARD

This paper has given a brief overview of slimhole drilling for geothermal exploration, both worldwide and in Indonesia. Slimhole drilling might become an option to confirm the existence of geothermal resource with a fraction of the price of standard drilling. However, there are several challenges such as limited rig availability, technical limitation of slimhole drilling, and lack of experienced personnel that should be carefully considered.

6.1. Path Forward

Further follow-up studies to this paper is required to thoroughly assess slimhole drilling for geothermal exploration in Indonesia:

6.1.1. Assessment on the potential subsurface objective that cannot be accommodated by slimhole well

Several subsurface objectives such as obtaining borehole imaging tools is currently cannot be satisfied by slimhole well due to logging tools size limitation. Further assessment is required on how to address this issue, whether by requesting smaller logging tools or by slightly changing the well size. The implication of such changes to the drilling rig and equipment required and estimated drilling cost should also be considered.

6.1.2. Market survey for rig availability and further engineering assessment for any modifications required

As there is no currently ready-to-use coring rig for geothermal or multipurpose rig in Indonesia, a market survey and assessment should be conducted. Any modifications required to enable the rig to operate safely in geothermal environment should also be carefully considered during the planning to evaluate its impact on the total drilling cost.

7. REFERENCES

- Apriani, D., Randle, J., & Paripurna, A. (2018). Government Drilling Program for Geothermal Exploration in Indonesia. *Proceedings 40th New Zealand Geothermal Workshop*. Taupo: New Zealand.
- Boart Longyear. (2020). GLOBAL PRODUCT CATALOGUE: CORING RODS AND CASING. Boart Longyear. Retrieved from http://app.boartlongyear.com/brochures/CoringRodsCasingCatalog_2020_797.pdf
- Darma, S. (2016). Indonesia: Vast geothermal potential, modest but growing exploitation. In R. DiPippo (Ed.), *Geothermal Power Generation: Developments and Innovation* (pp. 609-643). Woodhead Publishing.
- Daud, Y., Nuqramadha, W., Fahmi, F., Pratama, S., Rahman, K., & Subroto, W. (2017). Discovering “Hidden” Geothermal Reservoir in Blawan-Ijen Geothermal Area (Indonesia) Using 3-D Inversion of MT Data. *The 1st Geo Electromagnetic Workshop (Geo-EM)*. Bandung.
- dela Pena, E. (2018). Drilling Technology (Managing Risks) - Slimhole Option. *Course Material Postgraduate Certificate in Geothermal Energy Technology University of Auckland*. Auckland, New Zealand.
- Direktorat Panas Bumi. (2020). Pengembangan Panas Bumi Indonesia. *Presentasi Kementerian Energi dan Sumber Daya Mineral (ESDM) Direktorat Jenderal Energi Baru Terbarukan dan Konservasi Energi (EBTKE)*. Jakarta, Indonesia.
- Do, Q., Doan, T., Hoang, T., Nguyen, T., & Tran, T. (2019). Potential Application of Slimhole Drilling Technology to Geothermal Wells in Vietnam. In M. Randolph, D. Doan, A. Tang, M. Bui, & V. Dinh (Ed.), *Proceedings of the 1st Vietnam Symposium on Advances in Offshore Engineering* (pp. 239-244). Hanoi: Springer.
- Elders, W. (2007). Why coring should be part of any exploratory high-temperature drilling project, as illustrated by the case histories of the Salton Sea Scientific Drilling Project (SSSDP) and the planned Iceland Deep Drilling Project (IDDP): a plea for technology developm. *Engine Workshop 4*. Reykjavik, Iceland: University of California. Retrieved from http://engine.brgm.fr/web-offlines/conference-Drilling_cost_effectiveness_and_feasibility_of_high-temperature_drilling_-_Reykjavik_Iceland_Workshop4/other_contributions/18-slides-0-26_EldersTalk.pdf
- ESMAP. (2016). *Comparative Analysis of Approaches to Geothermal Resource Risk Mitigation: A Global Survey*. World Bank.
- Finger, J., Jacobson, R., Hickox, C., Combs, J., Polk, G., & Goranson, C. (1999). *SLIMHOLE HANDBOOK: Procedures and Recommendation for Slimhole Drilling and Testing in Geothermal Exploration*. California: Sandia National Laboratories.
- Hinchliffe, S. (2011). Deep Slimhole Drilling for Geothermal Exploration - Confirming Conceptual Models based on Geophysical Survey. *The Geothermal Communities Project E-learning Material*. Sinclair Knight Merz Ltd, Auckland. Retrieved January 16, 2020, from https://geothermalcommunities.eu/assets/elearning/2.22.Slimhole_drilling_-_Targeting_geophysics-public.pdf
- Hochstein, M., & Sudarman, S. (2008). History of geothermal exploration in Indonesia from 1970 to 2000. *Geothermics*, 220-266. doi:<https://doi.org/10.1016/j.geothermics.2008.01.001>.
- Mackenzie, K., Ussher, G., Libbey, R., Quinlivan, P., Dacanay, J., & Bogie, I. (2017). Use of Deep Slimhole Drilling for Geothermal Exploration. *Proceedings The 5th Indonesia International Geothermal Convention & Exhibition (IIGCE) 2017*. Jakarta.
- Nielson, D., & Garg, S. (2016). Slim Hole Reservoir Characterization for Risk Reduction. *PROCEEDINGS, 41st Workshop on Geothermal Reservoir Engineering*. Stanford: Stanford University.
- Poernomo, A., Satar, S., Effendi, P., Kusuma, A., Azimudin, T., & Sudarwo, S. (2015). An Overview of Indonesia Geothermal Development – Current Status and Its Challenges. *Proceedings World Geothermal Congress 2015*. Melbourne.
- Prasetyo, M. (2020). Understanding Geoscience Aspects in Geothermal Drilling. *Training Material: "Managing Geothermal Drilling Project in Indonesia"*. Depok, Indonesia: Universitas Indonesia / Pertamina Geothermal Energy.
- Purba, D., Adityatama, D., Hasyimi, S., & Chandra, V. (2018). Land Acquisition Process and Challenges in Geothermal Exploration Project in Indonesia. *6th Indonesia International Geothermal Convention & Exhibition*. Jakarta.
- Purba, D., Adityatama, D., Umam, M., & Muhammad, F. (2019). Key Considerations in Developing Strategy for Geothermal Exploration Drilling Project in Indonesia. *PROCEEDINGS, 44th Workshop on Geothermal Reservoir Engineering*. Stanford: Stanford University.
- Rott, I. (2019). Slim-Hole Coring and Production Well Drilling in Geothermal Applications. *Indonesia Geothermal Association Workshop & Group Discussion about New Technology Rig with Drilling Method Innovations applicable in the Geothermal Sector of Indonesia*. Jakarta, Indonesia: PRAKLA Bohrtechnik.
- Schlumberger. (2020). *Oilfield Glossary: Slim Hole Well*. Retrieved February 25, 2020, from Oilfield Glossary: https://www.glossary.oilfield.slb.com/en/Terms/slim_hole_well.aspx

- Sudarman, S., & Hochstein, M. (2014). History of Geothermal Exploration in Indonesia (1970-2010). *New Zealand Geothermal Workshop 2014*. Auckland.
- Sunarso. (2020). Ijen Slimhole Drilling. *Training Material: "6 Days Training Managing Geothermal Drilling Project in Indonesia"*. Depok, Indonesia: Universitas Indonesia / Medco Power.
- Thorhallson, S., & Gunnsteinsson, S. (2012). Slim Wells for Geothermal Exploration. *Short Course on Geothermal Development and Geothermal Wells*. Santa Tecla, El Salvador: UNU-GTP.
- Thorhallsson, S. (2016). Geothermal Well Designs - Large Holes vs Slimholes. *Training Material 5th ITB International Geothermal Workshop*. Bandung, Indonesia.