

## Production-Injection at the Costa Rica Geothermal Fields 1994 – 2018: Dr. Alfredo Mainieri Protti (formerly Miravalles) and Pailas

Federico Nietzen and Leonardo Solís  
P. O. Box 10032-1000, San José, Costa Rica  
fnietzen@ice.go.cr, lesoli@ice.go.cr

**Keywords:** Production, injection, Dr. Alfredo Mainieri Protti, Miravalles, Pailas, Costa Rica

### ABSTRACT

The electricity capacity (from the geothermal resource) installed in Costa Rica is approximately 215 MWe in 2018, increased to 270 MWe with the Pailas II Unit by 2019. There are four steam units installed in the Dr. Alfredo Mainieri Protti field (formerly Miravalles Geothermal Field): Unit 1 (55 MWe, although it can reach 60 MWe, 1994), Wellhead Unit (5 MWe, 1995), Unit 2 (55 MWe, although it can reach 60 MWe, 1998) and Unit 3 (29 MWe, 2000), and also a binary plant: Unit 5 (19 MWe, 2004). Pailas has a binary unit with a production of 42 MWe installed (2011). However, the commercial production of the second unit (Pailas II Unit, steam unit) begins in 2019, with a contribution of about 55 MWe. The Dr. Alfredo Mainieri Protti field has supplied the steam and brine needed to generate over twenty four years of exploitation (1994-2018), while Pailas field (Unit I) has approximately seven years of operation, with changes in the configuration of wells. The performance of the fields and changes in strategies, in terms of production-injection, are described in the following sections.

### 1. INTRODUCTION

The fuel crisis of the seventies, product of the embargo decreed by the Organization of Petroleum Producing Countries (OPEC), was a motivation for the country to look for alternatives energy sources, thus initiating the analysis of the use of geothermal energy. At that time, the Miravalles volcano area was chosen as the starting point. The first three wells were drilled in 1979, with satisfactory results. Between 1984 and 1986, another six wells were drilled, confirming the existence of an exploitable geothermal resource and initiating the feasibility study of the first geothermal plant. In 1994, the first geothermal plant in Costa Rica was inaugurated. All this led by the pioneer and emblematic figure of the Dr. Alfredo Mainieri Protti, to whom Costa Rican geothermal history will always be linked.

Exploitation of geothermal energy began in Costa Rica in 1994 with the installation of a power plant of 55 MWe in the Miravalles zone (Figure 1). By 2003, the installed capacity increased to about 166 MWe with the integration of new units, and it has kept so until nowadays. Furthermore, a new geothermal field was developed in Pailas zone in 2011 (Figure 1). The production of Pailas field began with the installation of a binary plant of 35 MWe (42 MWe gross). By the moment, there are two geothermal fields in exploitation phase, Dr. Alfredo Mainieri Protti and Pailas I. Pailas II development will start the commercial exploitation phase in 2019, with a contribution of 55 MW. Some prospective areas are planned to be researched soon according to the plan for Costa Rica's geothermal expansion (Table 1).

**Table 1. Geothermoelectric capacity installable in Costa Rica (in MWe) (Cataldi and Mainieri, 1995)**

Area	Capacity that can be fed by the reserves (MWe)			Priority
	Single Flash	Dual Flash	Average	
Miravalles	164	213	189	I
Rincón de la Vieja (Las Pailas)	137	177	157	
Irazú - Turrialba	101	130	116	II
Tenorio	97	123	110	
Platanar	97	122	110	
Poás	90	116	103	
Barva	85	109	97	III
Fortuna	61	77	69	
Orosi - Cacao	33	41	37	
Seven other areas*	---	---	---	IV
<b>Total</b>	<b>865</b>	<b>1108</b>	<b>987</b>	

\*: Caño Negro, Liberia, S. Jorge, Tilarán, Puerto Viejo, San José and Tigra

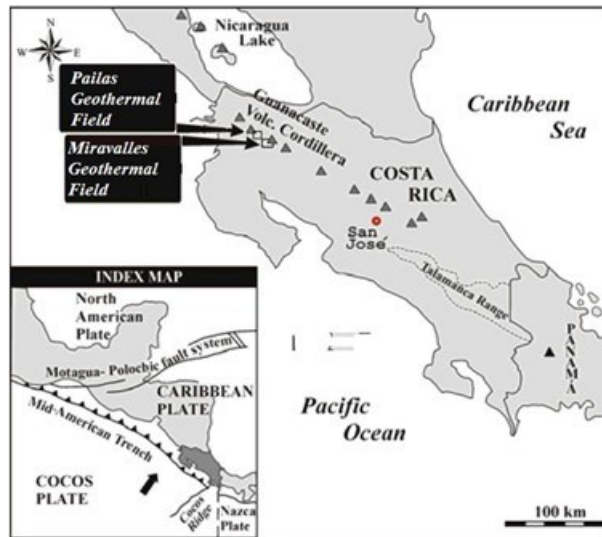

**Figure 1:** Location map showing Costa Rica and two Geothermal Fields: Dr. Alfredo Mainieri Protti (Miravalles) and Pailas.

In Dr. Alfredo Mainieri Protti, the current capacity installed is around of 165 MWe (Table 2), thus remaining for an extended period of time. The generating behavior annually is shown in Figure 2. There have been changes in the mass ratios, pressure drops in the system, cooled fronts, among others. Wells have been closed and new ones have been opened and integrated, in order to maintain the productive capacity of the field. On the other hand, Pailas I has a different context than the Dr. Alfredo Mainieri Protti. The commercial development began from May, 2011 with 35 MWe (42 MWe gross) (Table 2). The energy produced annually is displayed in Figure 3. Several wells were drilled with directional technology, giving good results.

The number of wells for both geothermal fields is shown in Table 3.

**Table 2.** Installed capacity, net power and gross power in Dr. Alfredo Mainieri Protti (Miravalles) and Pailas I Geothermal Fields

<i>Unit</i>	<i>Power according to plate (MWe)</i>	<i>Net Power (MWe)</i>	<i>Gross Power (MWe)</i>	<i>Type</i>	<i>Start-up date</i>	<i>Final date</i>	<i>Belongs to</i>
Unit 1 (Dr.Alfredo Mainieri Protti 1)	55.1	55	60	SF	March, 1994		ICE
WHU-1	5.0	5	5	BP	January, 1995 December 2006	July, 2006	ICE
WHU-2	5.0	5	5	BP	September, 1996	August, 1998	CFE
WHU-3	5.0	5	5	BP	February, 1997	January, 1999	CFE
Unit 2 (Dr.Alfredo Mainieri Protti 2)	55.1	55	60	SF	August, 1998		ICE
Unit 3 (Dr.Alfredo Mainieri Protti 3)	29.5	26	29	SF	February, 2000 March, 2015	February, 2015	GG ICE
Unit 5 (Dr.Alfredo Mainieri Protti 5)	21.0	15	19	ORC	November, 2003		ICE
Unit 1 (Pailas I)	51.8	35	42	ORC	May, 2011		ICE
<b>Total</b>	<b>212.5</b>	<b>191</b>	<b>215</b>				

SF = Single flash; BP = Backpressure; GG = Geoenergía de Guanacaste Ltda., in a BOT system (Build-operate-transfer); ORC = Organic Rankine Cycle. It is a binary plant; ICE = Instituto Costarricense de Electricidad; CFE = Comisión Federal de Electricidad (México); WHU = Wellhead Unit. The WHU-1 changed the position during 2006 to other zone

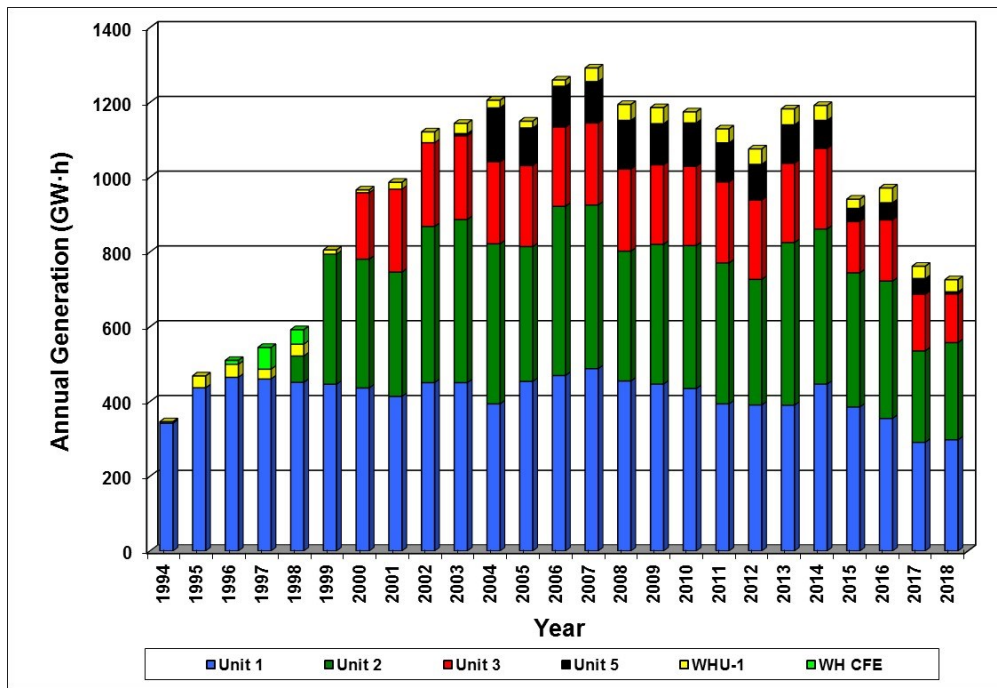

Figure 2: Energy production at Dr. Alfredo Mainieri Protti Geothermal Field (1994-2018).

Table 3. Quantity and type of wells in the Dr. Alfredo Mainieri Protti and Pailas I Geothermal Fields

Well Type	Number of wells according Geothermal Field*	
	Dr.Alfredo Mainieri Protti	Pailas I
	Producers	32
Injectors	9	8
Observers	13	5
No usable	3	2
<b>Total</b>	<b>57</b>	<b>21</b>

\* Area: 21 km<sup>2</sup> Dr.Alfredo Mainieri Protti, 10 km<sup>2</sup> Pailas

In Pailas I was implemented the concept of "square" pads (small quadrant), which contains two, three or four wells with directional drilling. This optimizes the resources since it reduces costs of surface pipe connection; land used, and allows the underground access to not permissible sites as national parks.

The installed unit is a mixed binary plant, with two modules. This unit operates with steam and brine. It has only one separation station, which provides approximately 85 kg/s of steam and 400 kg/s of liquid.

Despite the success accomplished with the small pads and the directional drilling, some negative effects in the evolution of the field have been monitored and described. Torres (2014) indicates that even with the short time of operation, some changes in wells have been displayed; studies displayed the arrival of injection in few days. In that matter, two wells have been affected directly; however, another well was drilled and joined in 2013, which gave support to the production.

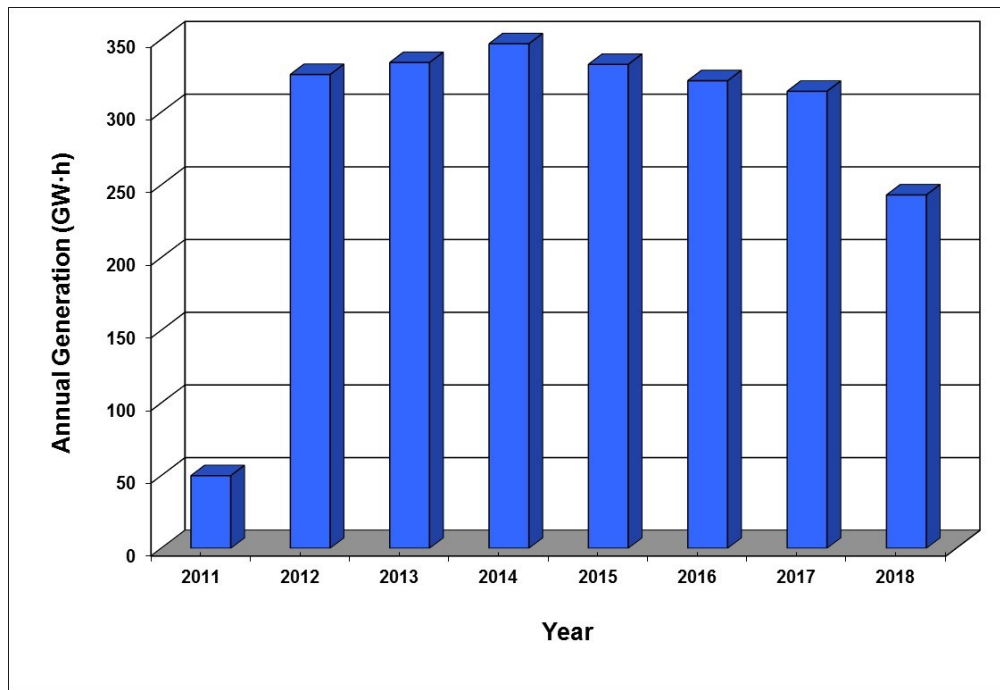

**Figure 3: Energy production in Pailas I Geothermal Field (2011-2018). The field produces from May 2011; however, the generation accounting begins in November 2011 in the plant (production phase).**

## 2. DR. ALFREDO MAINIERI PROTTI GEOTHERMAL FIELD

### 2.1 Production

The biphasic fluids from several wells (between two and five) are sent to separation stations. There are seven main separation stations and four minor stations (one at the wellhead unit, WHU-1, the others at the acid wells).

The separation stations are also called satellites, and each one is capable of separating a maximum of 60 kg/s of steam. The satellites supply the steam and the brine needed by the generating units.

A general description of the production behavior of each station is presented in the following sections. While there has been a decrease in total masses (and brine) in recent years, the vapor rate remained relatively stable until 2014 due to the increased enthalpy of the system. However, after 2014, a decrease in steam (as well as the total mass) was observed as time passed, which has affected the generation of energy.

Some wells have been closed due to the field evolution. Nevertheless, new wells have been opened in order to mitigate the effect of the field abatement.

Figure 4 (G Sistema. 2018, modified) shows the distribution of wells and Units at Dr. Alfredo Mainieri Protti Geothermal Field.

#### 2.1.1 Separation Station 1

This station begins production with the integration of the Generating Unit 1, the beginning of geothermal exploitation (March 1994). Originally steam was sent to the Generating Unit 1, however, the steam was changed to the Generating Unit 2 in November 2002 by the high gas content (non-condensable gases NCG). Generating Unit 2 had a higher extraction capacity than Generating Unit 1.

The production history of the Separation Station 1 is variable (Figure 5). The station has a period of high and sustained production from March 1994 to June 1998 (integrated wells PGM-01, PGM-05, PGM-10, PGM-11 and PGM-31). The production starts to decline by the change the PGM-05 well to the Separation Station 4, due to the integration of the Generating Unit 2 (March 1998). The flow in the Separation Station 1 declines once again in February 2000 with the commissioning of the Generating Unit 3 and the change the PGM-11 well to the Separation Station 7. Subsequent to March 2000, the Separation Station 1 has had variations in flow, due to field evolution and integration-withdrawal wells (e.g. PGM-65 - September 2001 to nowadays - PGM-63 - April 2002 to August 2013 and from September 2010 to nowadays - PGM-68 - February 2013 to nowadays - PGM-70 - February 2017 to nowadays - the PGM-01 was closed - March 2003 -).

Wells that currently feed the Separation Station 1 are the PGM-10, PGM-31, PGM-63, PGM-65, PGM-68 and PGM-70. Sometimes the PGM-05 well feeds this Station, but most of the time goes to the Separation Station 4. The Separation Station 1 yields 45 kg/s of steam and 96 kg/s of brine, with a percentage of gases of 1.6% (w/w).

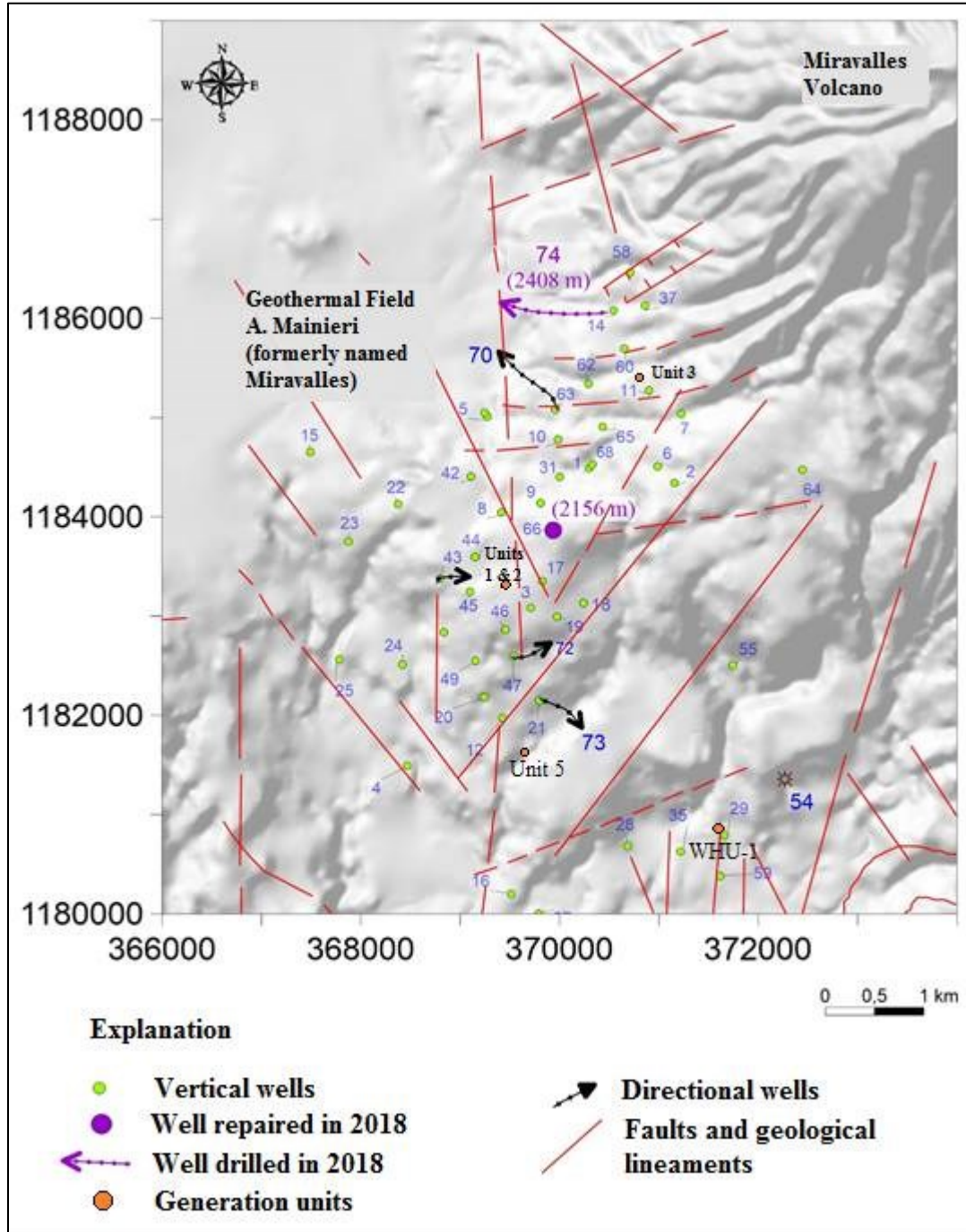

Figure 4: Distribution of wells and Units at Dr.Alfredo Mainieri Protti Geothermal Field. (G Sistema. 2018, modified).

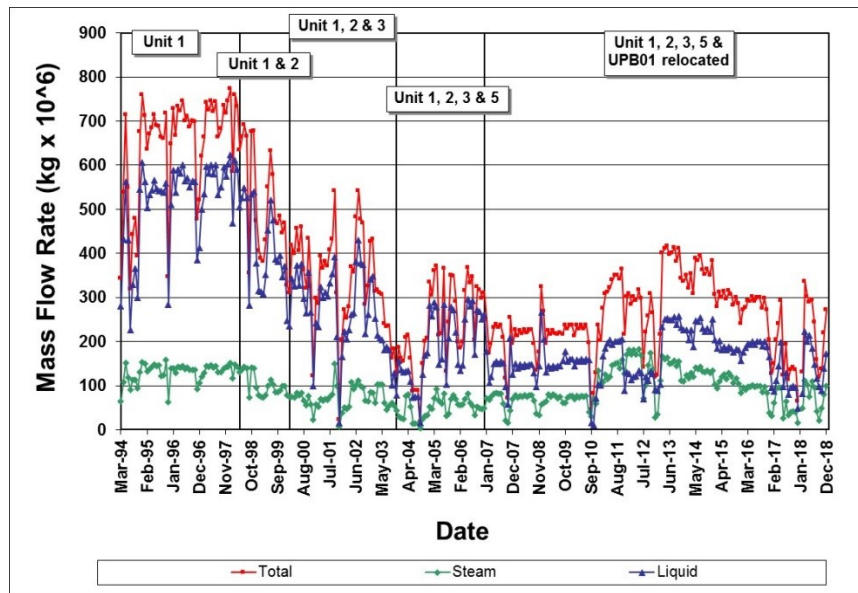

Figure 5: Mass flow rates at Separation Station 1.

2.1.2 Separation Station 2

As the Separation Stations 1 and 3, the Separation Station 2 begins production with the integration of the Generating Unit 1 (March 1994).

Slow decay is observable in production from March 1994 to May 1998 (Figure 6), when the Generating Unit 2 is integrated. The Station was fed by the PGM-03, PGM-17 and PGM-46 wells. In May 1998, the PGM-46 well is changed to the Separation Station 6, then the Station 2 lowered production. In 2000, PGM-19 acid well started production giving support to the Separation Station 2; however, the well was withdrawn in March 2011 due to production problems. The last well integrated until 2018, was the PGM-18 in Jun 2016.

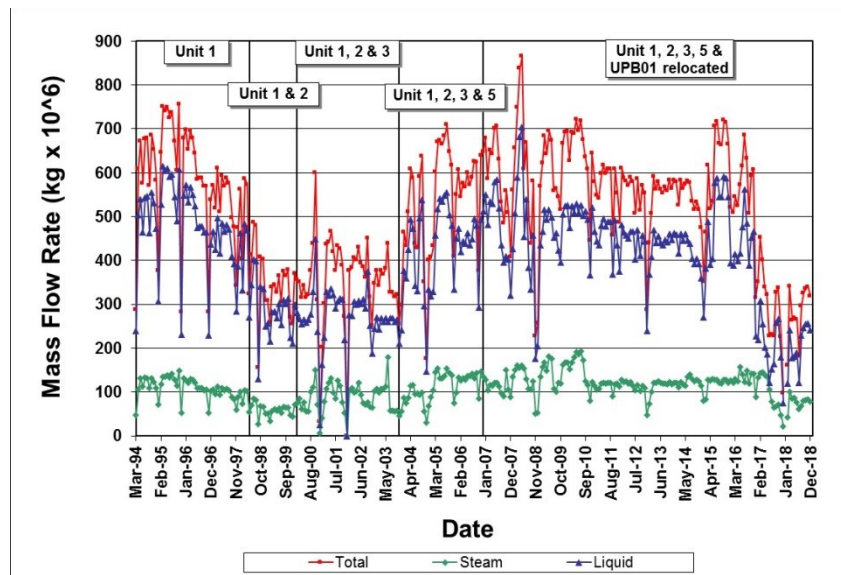

Figure 6: Mass flow rates at Separation Station 2.

The Separation Station 2 is now powered by the wells PGM-03, PGM-17, PGM-18, PGM-19 and PGM-66. Sometimes the well PGM-46 has been integrated; however, this well remains exclusively in the Separation Station 6 now. Separation Station 2 provides 35 kg / s of steam and 100 kg / s of brine, gases with a percentage of 1.1% (w/w). In February 2017 there was a decline in the flow of the station,

around 60 kg / s of steam to the current value; due to exploitation policies (reserve of wells PGM-03 and PGM-66, restriction of wells PGM-17 and PGM-19).

2.1.3 Separation Station 3

Separation Station 3 is fed by wells PGM-20, PGM-21 and more recently, PGM-73 (October 2016). The PGM-12 well was withdrawn since June 2016 due to stabilization problems (head pressure drop).

Under current conditions, it separates 44 kg/s of steam and 250 kg/s of brine, with a gases percentage of the 1.3 % (w/w). Figure 7 shows that the steam supply from this station increased from March 1994 to March 1998, when Unit 2 came online. From March 1998 to March 2000 the steam supply decreased slightly as a result of commissioning Unit 2 (Separation Station 6); mainly because its proximity to the production wells that supply the steam for Separation Station 3. With the new production wells that feed Station 6, this sector of the reservoir re-equilibrates to supply the geothermal flow to Separation Stations 3 and 6. The steam supply at Separation Station 3 has decreased slightly from March 2000 to September 2016, where the new well PGM-73 is integrated a month later, giving support to the system.

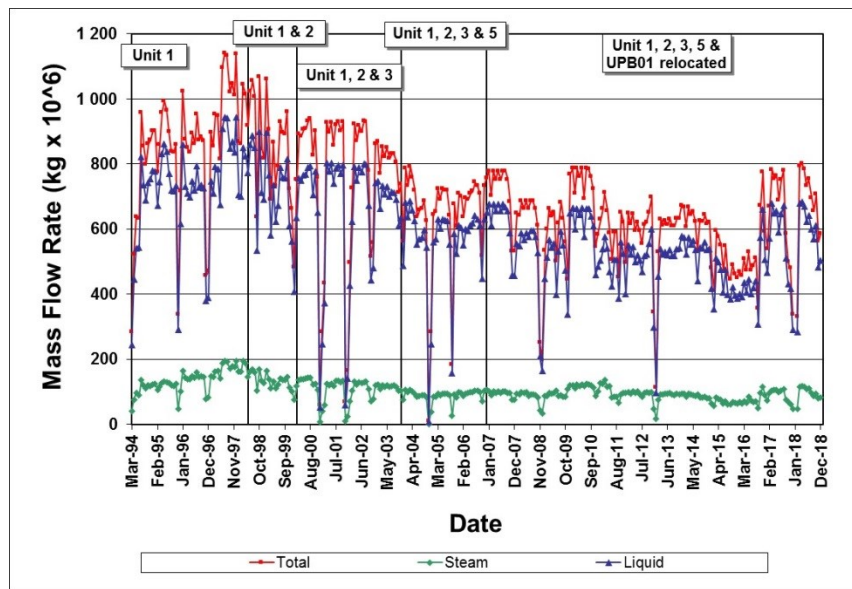

Figure 7: Mass flow rates at Separation Station 3.

2.1.4 Separation Station 4

The Separation Station 4 began operating with the commissioning of Unit 2 in March 1998 (as can be seen in Figure 8). The steam supply increased from March 1998 until August 2001. From October 2001 to October 2010 the steam supply was kept more or less constant depending on the requirements of the generating units. However, from November 2010 until December 2011, Units 1 and 2 remain at low load (45 MW), so the flow is restricted in the station. After this period, the production is decreased mainly by effect of the PGM-08 well; the brine flow has decreased slightly by enthalpy increasing during this period.

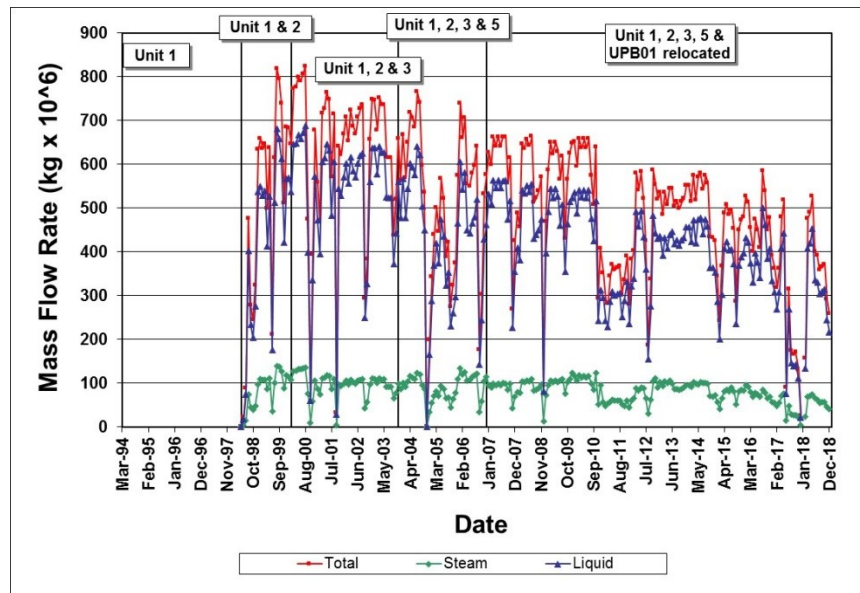

Figure 8: Mass flow rates at Separation Station 4.

Separation Station 4 is fed by wells PGM-05, PGM-08, and PGM-42. Under present conditions, it separates 27 kg/s of steam and 160 kg/s of brine, with a gases percentage of the 0.4 % (w/w). The flow from well PGM-05 can also be separated at Separation Station 1. Separation Station 4 separated the geothermal fluid for Unit 2 from March 1994 until October 2002. Since then, the steam from Separation Station 4 has been sent to Unit 1, because Unit 1 has a lower capacity to handle non-condensable gases.

2.1.5 Separation Station 5

Figure 9 shows that, like Separation Stations 4 and 6, this station began operation with the commissioning of Unit 2 in March 1998. The steam supply slightly increased from March 1998 to June 2004, kept constant from June 2004 to December 2006 and decreased slightly until December 2018. However, the brine flow (and total flow) strongly decreased from August 2003 to December 2018 by enthalpy increasing of field.

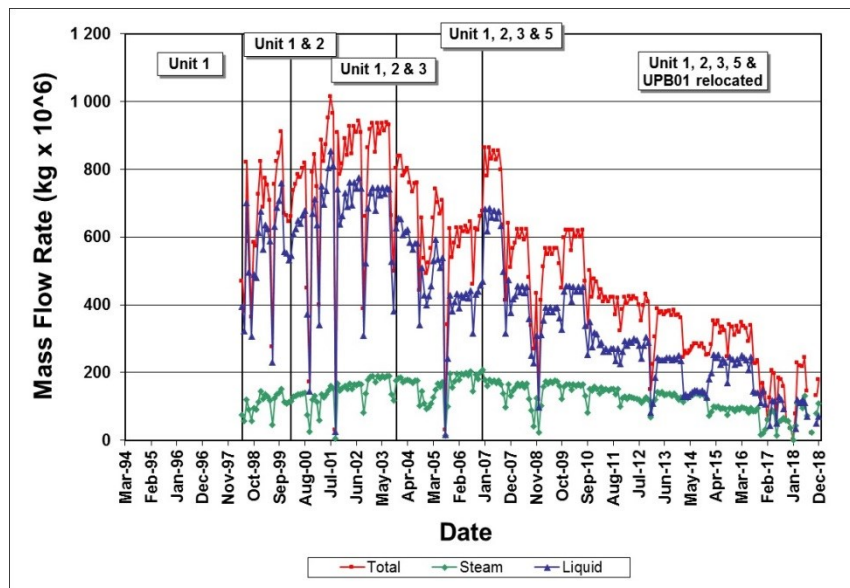

Figure 9: Mass flow rates at Separation Station 5.

Separation Station 5 is fed by two wells, PGM-44, and PGM-45. It is not possible to keep the maximum production of the well PGM-44; the wellhead pressure (maximum discharge) is lower than pressure system. The well PGM-43 was withdrawn in March 2011 according to production problems. Under current conditions, the Separation Station 5 separates 54 kg/s of steam and 42 kg/s of brine, with a gases percentage of the 2.0 % (w/w).

### 2.1.6 Separation Station 6

Figure 10 shows the behavior of production with respect to time, of the Separation Station 6. This station began its operation with the commissioning of Unit 2 in March 1998, same as the Separation Stations 4 and 5.

It began operation with wells PGM-46, PGM-47 and PGM-49; all wells changed over time. The well PGM-46 had deepened (June 2001 - November 2001) after it began to slowly decrease its production rate. The result was satisfactory, a new production zone was found. In January 2005, the well PGM-47 was withdrawn from production because the wellhead pressure was not high enough to connect it to the gathering system; the effect was minimum in the curves. In the last period, the well PGM-49 kept reduced until it finally closed in December 2010. Then the Separation Station 6 was fed by a single well. Therefore, it was decided to seal the initial zone of the well PGM-47, to deepen it and to find new zones, with favorable results; different geochemical and production characteristics was obtained, then its name was changed to PGM-72 and it was integrated in May 2012.

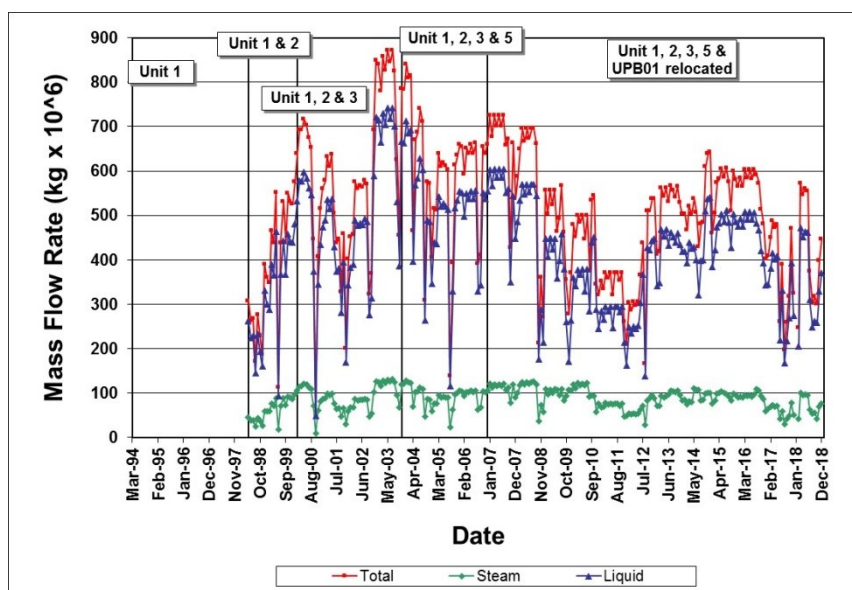

**Figure 10: Mass flow rates at Separation Station 6.**

Separation Station 6 is fed by wells PGM-46, PGM-67 (October 2014) and PGM-72. In the last two years, the PGM-49 well has been tried to integrate without success (low well pressure). Under the present conditions, it separates 37 kg/s of steam and 180 kg/s of brine, with a gases percentage of the 1.0 % (w/w).

### 2.1.7 Separation Station 7

The Separation Station 7 began operation in March 2000 with the commissioning of Unit 3 (BOT), and its steam rate remained constant from March 2000 to June 2000 (Figure 11). After this period, steam production increased because well PGM-62 was connected to the separation station. Steam production from this station increased slightly from July 2000 to August 2004 and decreased strongly from December 2004 to August 2006. Well PGM-62 has been closed since May 2006 because of the high non-condensable gas content of its steam, but well PGM-02 was connected in the same month to supply the steam lost from PGM-62. Later, the well 62 is again integrated to production (October 2012); in the same month, the well PGM-14 was withdrawn from production because the wellhead pressure was not high enough to connect it to the gathering system.

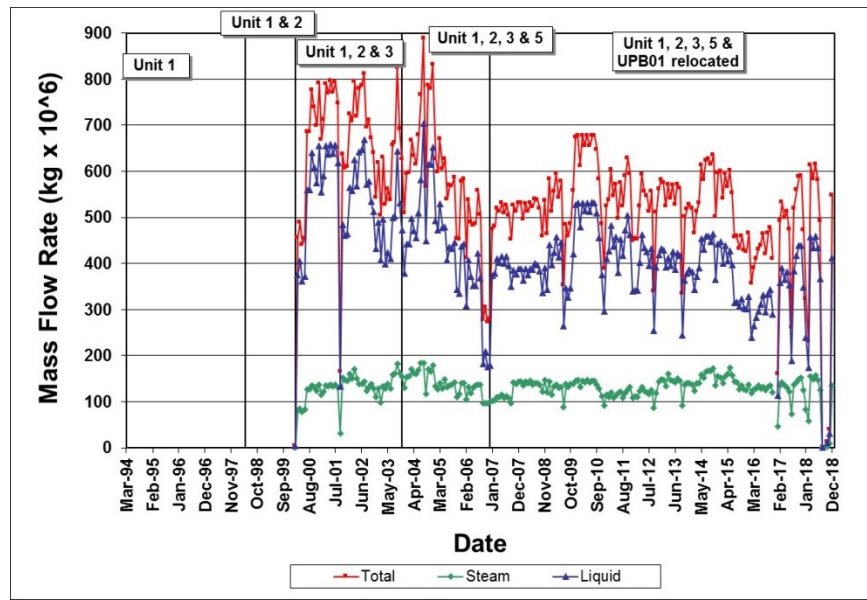

Figure 11: Mass flow rates at Separation Station 7.

In 2015, Unit 3 (related to Separation Station 7) is transferred to ICE, after 15 years operating under the BOT modality. However, the behavior of some wells remained unstable, such as well 14. This well is integrated and withdrawn for periods. The well PGM-60 was withdrawn for mechanical cleaning in June 2016 and it was integrated again in January 2017 with good results. In the same month, the PGM-37 was also integrated as system support. However, this well is not stable, due to pressure and power problems.

There was a negative effect on the production of this station (and Unit 3) due to the damage caused by Hurricane Otto on the surface infrastructure. These systems were out from November 2016 to January 2017.

Separation Station 7 is fed by wells PGM-02, PGM-07, PGM-11, PGM-14, PGM-37, PGM-60 and PGM-62. Under current conditions it separates 56 kg/s of steam and 170 kg/s of brine, with a gases percentage of the 1.7 % (w/w).

### 2.1.8 Wellhead Unit 2 at well PGM-45

As indicated in Table 2, two wellhead units from the Comisión Federal de Electricidad (México) were in operation while Unit 2 was under construction. Wellhead Unit 2 was fed by well PGM-45 from September 1996 to April 1998. Figure 12 shows that the steam production rate increased slightly while the unit was generating.

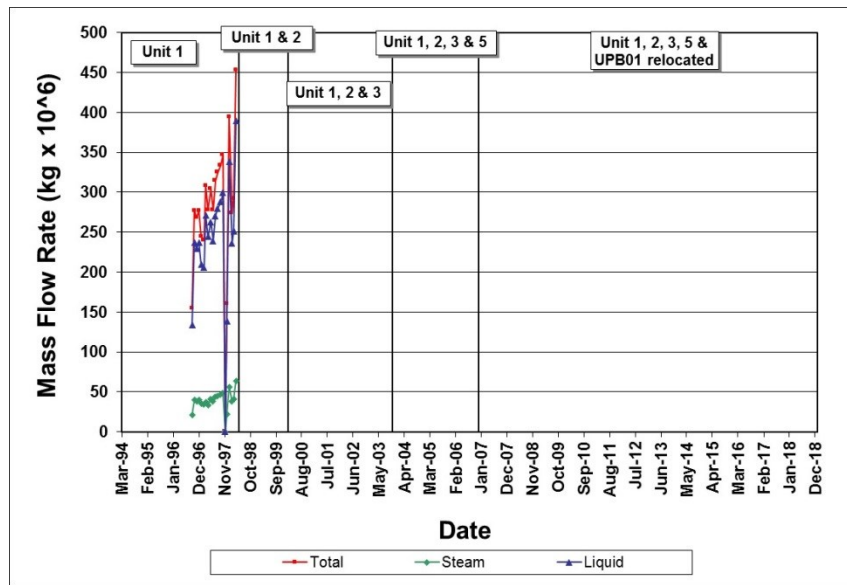

Figure 12: Mass flow rates at Wellhead Unit 2.

2.1.9 Wellhead Unit 3 at well PGM-29

Wellhead Unit 3 was the other wellhead unit from the Comisión Federal de Electricidad (México). This unit was fed by well PGM-29 from January 1997 to April 1998. Figure 13 indicates that the steam rate was kept almost constant while the unit was operating.

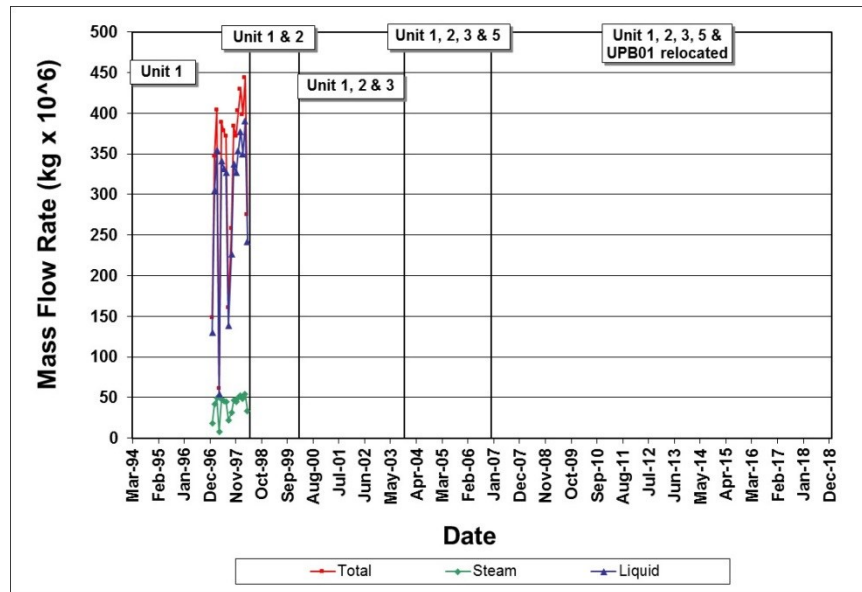

Figure 13: Mass flow rates at Wellhead Unit 3.

2.1.10 Wellhead Unit 1 at well PGM-29

The Wellhead Unit 1 (WHU1) was located in two different zones of Dr. Alfredo Mainieri Protti field. The first one was the central zone (from 1995 to 2006) which it was fed by the steam pipe of the Separation Station 1. The WHU1 contributed with 5 MW during this period, although production was variable through the year, as well as the Unit 1 maintenance (must be retired due it was connected to line that fed the Unit). However, when viewing another area with geothermal potential and find that the use of spare resource (steam)

began to decrease, it was decided to move the WHU1 to the second zone. The second zone (zone of well PGM-29) has a different context.

Moving the WHU1 to the area of well PGM-29 represented a significant improvement from different points of view. Not only mitigated the exploitation in the main production, where it was originally located; but also Units 1 and 2 optimized the use of this resource in its turbines previously used by the WHU1 (efficiency in these units is almost twice of the WHU1). In terms of electricity generation, there is an increase of the energy delivered by the WHU1 in its new location; as it is not being directly affected by proposed mitigation policies in other areas of the field or maintenance periods for the other units, the WHU1 can generate most of the time during the year (Nietzen, 2009). As an example, the WHU1 operated about 50% of the time in the central area, after relocating, it operates approximately 90%, 5 MW. However, this percentage decreased significantly in 2015 (50%, for maintenance reasons) and 2018 (13%, due to energy production at the national level from other sources, such as hydroelectric power).

In December 2006, the WHU1 began production in the southeastern part of the field (Figure 14.). Since then, the steam rate is relatively constant. There are periods of low productivity due to maintenances (one of them is from January to June 2015, and the longest from July to November 2010) and production policies (prioritization of other sources) as in 2018.

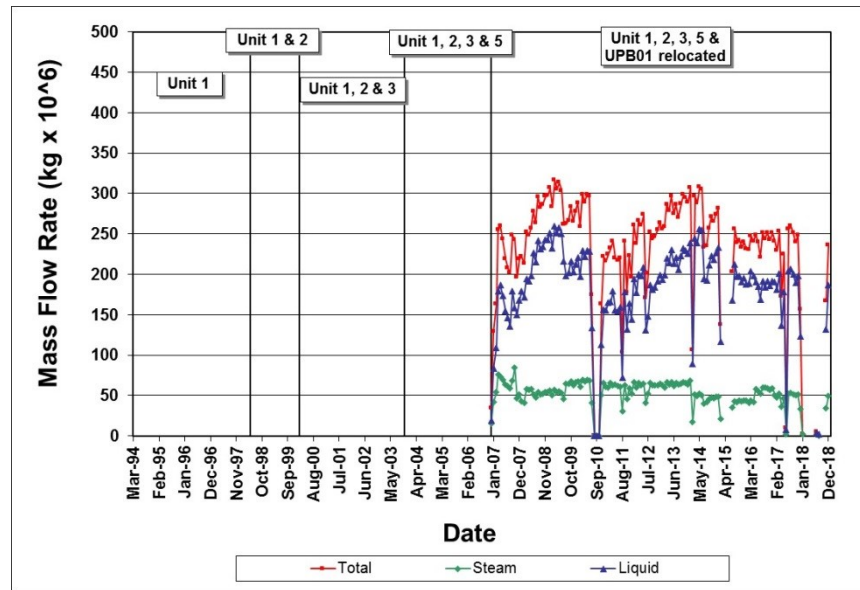

Figure 14: Mass flow rates at Wellhead Unit 1.

### 2.1.11 Field-Wide Production

Figure 15 shows the mass rate extraction from the Dr. Alfredo Mainieri Protti geothermal field since production began. The steam extraction rate increased gradually from May 1994 (380 000 tons/month) until August 2000 (820 000 tons/month). Since April 2000, steam production has increased from 745 000 to 844 000 tons/month, with the exception of maintenance periods. The production rate has decreased every year during September-December, mainly as a consequence of maintenance work on Units 1, 2 and 3. Liquid mass and total mass extraction have behaved in basically the same way: there was an increase from April 1994 (1.4 million tons of liquid per month) to May 1995 (2 million tons/month); they then fluctuated within a range of 1.7 to 2.5 million tons/month until April 1998. Thereafter, the total mass extraction increased from 2.7 to 4.9 million tons/month and the liquid mass increased from 2.3 to 4.1 million tons/month. This last increment is the result of the start-up of Units 2 and 3. From March 2001 to June 2004, total mass extraction stabilized at around 4.5 million tons/month and liquid mass extraction stabilized at around 3.5 million tons/month, and then slowly decreased through December 2014 (enthalpy increasing during this period). During 2009 and 2014, the total generation has decreased by about 13 MW, mainly because of the current gas extraction capacity of Units 1, 2 and 3, and a decrease of the total discharge rate of some of the production wells, which has affected the steam as well as the brine supply to the generation units. After this period, production continued to decline until the end of the study period, 2018. Some of the main causes are: exploitation policies in reducing extraction rates, prolonged periods of use of other sources of energy, natural decline of the field.

The behavior of the extraction curves coincides quite well with the increases in generation over these years as the different new units were commissioned.

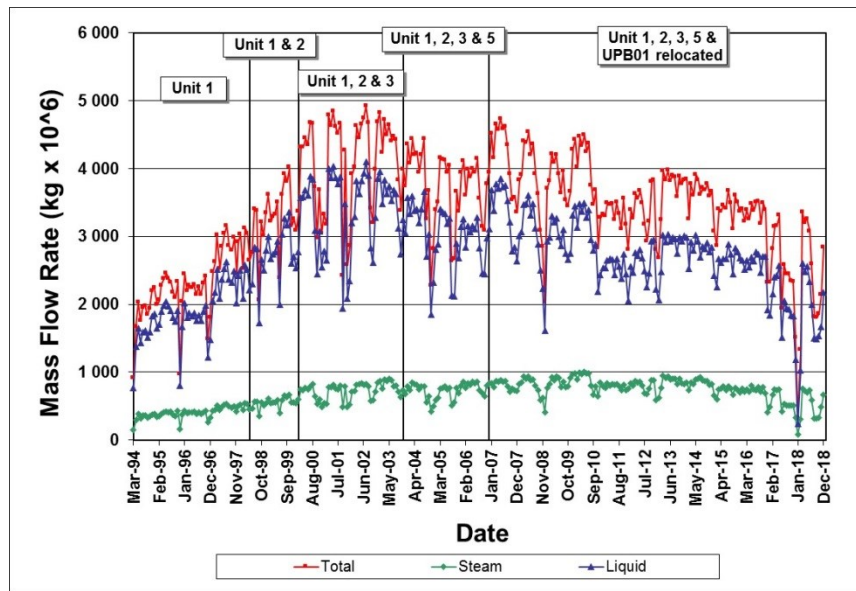

Figure 15: Mass flow rates at Dr. Alfredo Mainieri Protti Geothermal Field.

Figure 16 shows the cumulative production of liquid, steam and total masses from the geothermal field. All of these masses increased linearly from March 1994 until May 1998. When Units 2 and 3 began operation the slope of the curves became steeper, but the increases were still nearly linear over those periods (from April 1998 to March 2000 and from April 2000 to December 2016). In the last years of the graph, a change in the trend is observed, which indicates a masses reduction. By December 2018, the accumulated production was approximately 199.8 million tons of steam, 796.7 million tons of liquid and 996.5 million tons of total mass.

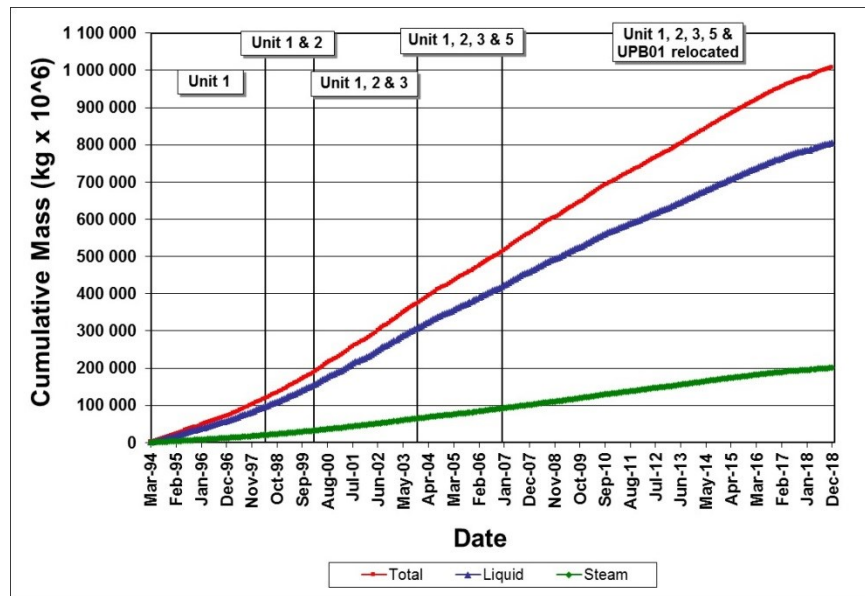

Figure 16: Cumulative mass extraction at the Dr. Alfredo Mainieri Protti Geothermal Field.

## 2.2 Injection

Injection at the Dr. Alfredo Mainieri Protti geothermal field has been divided into 12 periods. These periods as well as their initial and final dates are indicated in Table 4.

There are three sectors of the Dr. Alfredo Mainieri Protti geothermal field that have been used for hot-water injection (these are designated eastern, western and southern), as well as one cold injection sector, located in the southern part of the field. These sectors are described in the following sections.

**Table 4. Injection Periods**

<i>Period</i>	<i>Initial Date</i>	<i>Final Date</i>
	<b>March 1994</b>	<b>April 1998</b>
1	Commissioning of Unit 1. Injection line: 2 Wells: PGM-02, PGM-22, PGM-24.	Injection of liquid coming from Satellite 3 was changed from injection line 2 to injection line 3, due to the commissioning of Unit 2. Injection lines: 1, 2 and 3. Wells: PGM-22 and PGM-24.
	<b>May 1998</b>	<b>November 1998</b>
2	Injection of liquid from Satellite 3 was changed from injection line 2 to injection line 3, due to the commissioning of Unit 2. Injection lines: 1, 2 and 3. Wells: PGM-22 and PGM-24	The flow from PGM-05 had been separated at Satellite 1, but it was changed to Satellite 4. The flow from PGM-46 had been separated at Satellite 2, but it was changed to Satellite 6.
	<b>December 1998</b>	<b>February 2000</b>
3	Wells PGM-05 and PGM-46 were changed from Unit 1 to Unit 2.	Commissioning of Unit 3. Satellite 7 sends its liquid to injection line 1.
	<b>March 2000</b>	<b>November 2002</b>
4	Commissioning of Unit 3. Satellite 7 sends its liquid to injection line 1.	Increase in the contribution from Satellites 4 and 5 to the Western Injection Sector, wells PGM-22 and PGM-24.
	<b>December 2002</b>	<b>November 2003</b>
5	Increase in the contribution from Satellites 4 and 5 to the western injection sector, wells PGM-22 and PGM-24.	Commissioning of Unit 5
	<b>December 2003</b>	<b>July 2005</b>
6	Commissioning of Unit 5	Injection begins in well PGM-63
	<b>August 2005</b>	<b>December 2006</b>
7	Injection in well PGM-63 until August 2006	Production begins in well PGM-29
	<b>January 2007</b>	<b>September 2010</b>
8	Production in well PGM-29	Injection ends in well PGM-63
	<b>October 2010</b>	<b>December 2016</b>
9	Injection ends in well PGM-63	Reduction of production due to excess of other types of energy (hydroelectric plants)
	<b>January 2017</b>	<b>October 2017</b>
10	Reduction of production due to excess of other types of energy (hydroelectric plants)	Second reduction of production due to excess of other types of energy (hydroelectric power plants).
	<b>November 2017</b>	<b>February 2018</b>
11	Second reduction of production due to excess of other types of energy (hydroelectric power plants).	Second reduction of production due to excess of other types of energy (hydroelectric power plants).
	<b>March 2018</b>	<b>December 2018</b>
12	Second reduction of production due to excess of other types of energy (hydroelectric power plants).	Last data analyzed

### 2.2.1 Eastern Injection Sector

From 1994 to 2000, well PGM-11 sent its two-phase flow to an additional separation station called the “Plazoleta” (Pad). The steam was sent to Separation Station 1 and the brine to well PGM-02, located in the eastern sector of the field.

The Plazoleta separation station was very important when Unit 1 came online, because it allowed the steam coming from well PGM-11 to be used for generation of Unit 1. During injection Period 1, the injection rate remained more or less constant at about 120 000 tons per month (Figure 17). Injection in this sector began to decrease in Period 2, for several reasons: valve repairs, changes in deliverability

curves, and several activities in the wells such as changes of the capillary tubing (thus reducing the flow). Injection in well PGM-02 ended in December 1998, when there was no longer a need to supply more steam from well PGM-11 to Unit 1. Instead, PGM-02 was tested as a potential production well.

In Period 4, well PGM-02 was used for injection twice (in January and September 2001), in order to dispose of liquid from PGM-11 while Separation Station 7 was undergoing maintenance.

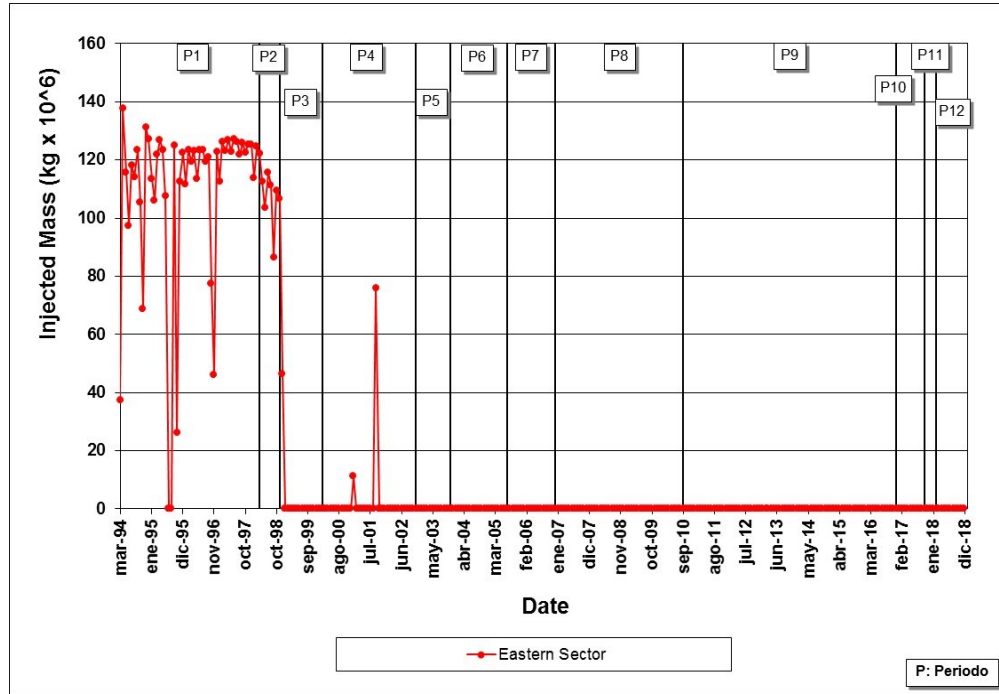
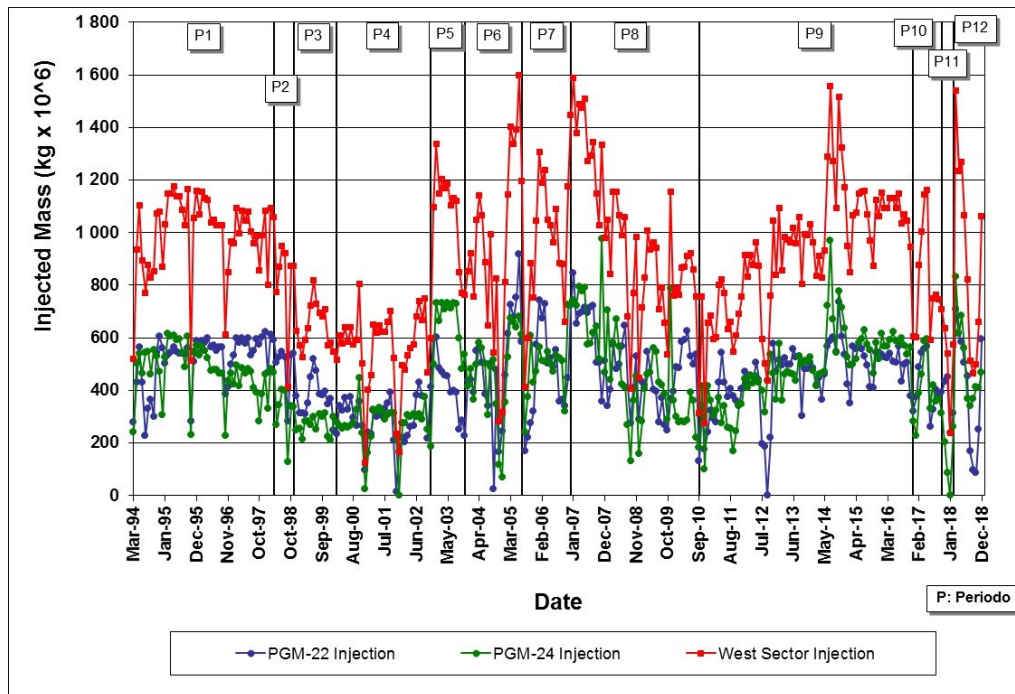

Figure 17: Eastern injection sector at the Dr. Alfredo Mainieri Protti Geothermal Field.

2.2.2 Western Injection Sector

The wells that contribute to injection in the western sector are PGM-22 (Separation Station 1) and PGM-24 (Separation Station 2). This injection sector has been utilized since the first plant was commissioned. Injection in the western sector was kept constant during Period 1 (1 100 000 tons per month, Figure 18). During Period 2, production from well PGM-05 was partially diverted to Separation Station 4, and totally diverted in Period 3 to Separation Station 4, decreasing the injection rate in this sector. Then, due to well PGM-05, the injection rate decreased further and was kept constant at 600 000 tons per month during Period 4.



**Figure 18: Western injection sector at the Dr. Alfredo Mainieri Protti Geothermal Field.**

During Period 5 there was an increment in the brine injected in the western sector because part of the liquid coming from Separation Stations 1 and 4 was diverted to wells PGM-22 and PGM-24, as recommended by ICE’s consultant, GeothermEx, Inc. in order to provide better support for the pressure decline in the reservoir. Unfortunately, wells PGM-01, PGM-10 and PGM-63 lost their productivity (Moya and Yock, 2004), and injection during Period 5 decreased from 1 300 000 tons per month to about 770 000 tons/month at the end of Period 5. During Periods 6 and 7, the total injection increased from 770 000 tons/month to an average of 1 000 000 tons/month, with some variation; high and low data are observed (eg. 1 500 000 and 280 000 tons/month). During Period 8, the total injection in this sector decreased from 1 500 000 tons/month to 900 000 tons/month by September 2010, slowly increasing to 1 300 000 during the period 9. There was variability in the periods 10, 11 and 12, going from about 800 000 tons/month to almost 1 600 000 tons/month.

### 2.2.3 Southern Injection Sector

Injection in the southern sector is distributed over three injection pipelines called collectors 1, 2 and 3. The mass behavior of each collector is shown in Figure 19. The brine rate injected through these collectors has depended on the operating conditions of the field. In Figure 19, the red curve (total injection in the southern sector) corresponds to the sum of the injection of the three collectors, and shows that injection rate was fairly constant from July 1994 until September 1996, then increased during the rest of Period 1 and during Periods 2 and 3, and the beginning of period 4 until August 2000, when annual maintenance took place on the generating units. Leaving aside the annual maintenance periods of the plants, injection was kept constant around 3 250 000 tons per month during Period 4.

At the beginning of Period 5, part of the fluid injected in the southern sector was moved to the western sector (following the advice of GeothermEx as mentioned above). As a consequence of this decision, injection in the southern sector decreased and remained constant at about 2 500 000 tons per month during Period 5 and half of Period 6 (August 2004).

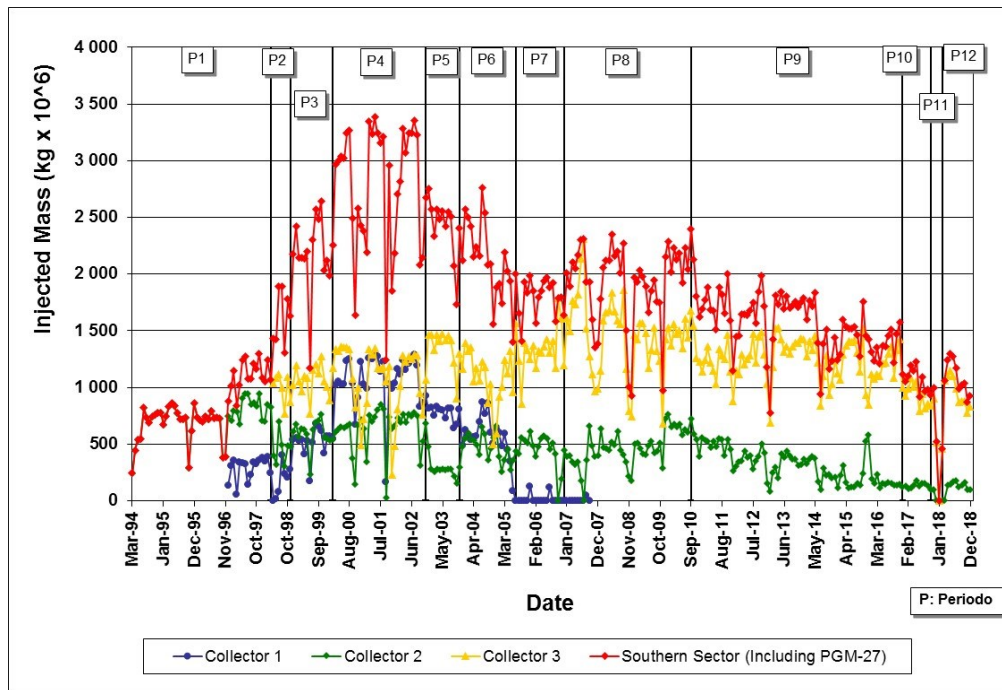
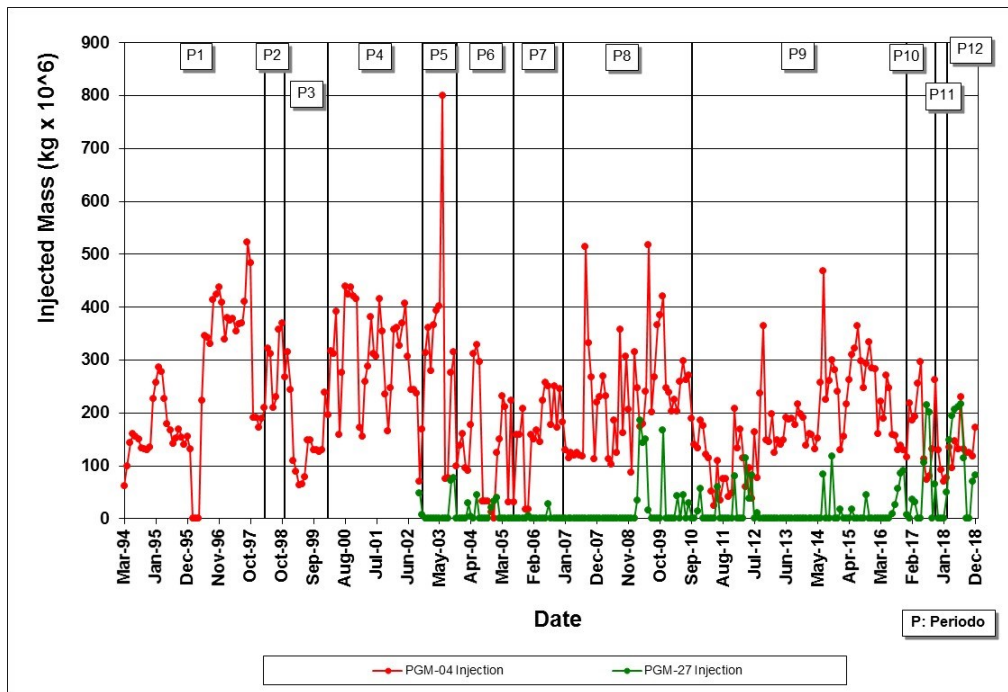

**Figure 19: Southern injection sector at the Dr. Alfredo Mainieri Protti Geothermal Field.**

From August 2004 to December 2006 (Periods 6 and 7) the injection rate has decreased slightly until 1 800 000 tons per month. From January 2007 to December 2014 the injection rate in the southern sector has fluctuated with changes in the operating conditions in the field; however, it has decreased slightly (the field mass decreases itself with time, and it increases the enthalpy). This condition has an effect on the generation of the binary Unit 5. At end of period 8, the injected flow is around of 1 900 000 tons per month, but in the periods 9, 10, 11 and 12, the injection decreases until reaching approximate values of 1 000 000 tons per month.

2.2.4 Cold Injection, Southwestern Sector

The condensed vapor from the generating units, the separated brines from the acidic wells (PGM-02, PGM-07 and PGM-19), commissioning and withdrawals productive systems, and the separated brine from deliverability tests (which is done periodically on the production wells) are all injected into the reservoir using cold injection system. This system consists of concrete pipelines running from each production well to five different ponds. There are concrete pipelines between the ponds, to carry brine from higher-elevation ponds to the lower ones. From the lowest elevation pond, the liquid is sent to PGM-04, the cold-injection well. Figure 20 shows the amount of separated brine that has been injected in this well between March 1994 and December 2018. The injection rates depend on the operating conditions of the field, and therefore have varied substantially.



**Figure 20: Cold injection, southern sector at the Dr. Alfredo Mainieri Protti Geothermal Field.**

In October 2002, a new cold injection line was constructed in order to have a spare and additional cold injection well (PGM-27), and also to improve the capacity of this system. As can be seen in Figure 19, the injection rate in PGM-27 (green curve) has been very low because this well has recently been added to the cold injection system and is used only as a back-up cold injection well. Recently, the brine of acid wells is not separated (exception PGM-19). The brine is used in hot injection and production of the binary Unit 5. Yet, injected brine flow of well PGM-04 was low (around 180 000 tons per month) but increased due to the integration of the well PGM-19 in the last months (around 260000 tons per month). However, there is an increase in the flow in the well PGM-27 in recent periods. With this, it seeks to reduce the contribution to the well PGM-04.

### 2.2.5 Field-Wide Injection

Figure 21 shows the overall history of injection at the Dr. Alfredo Mainieri Protti geothermal field. The total injection increased from 1 500 000 tons/month (beginning of Period 1) to 3 500 000 tons/month (beginning of Period 4), and was kept fairly constant (3 750 000 tons/month) until the beginning of Period 5, when it started to decrease, reaching 3 250 000 tons/month by November 2003. This decrease is mainly the result of a loss in production from the wells supplying Separation Station 1 (PGM-01, PGM-10, PGM-63). Beginning Period 6 until October 2010, the field-wide injection has been fluctuating depending on the operating conditions. However, it has decreased slightly.

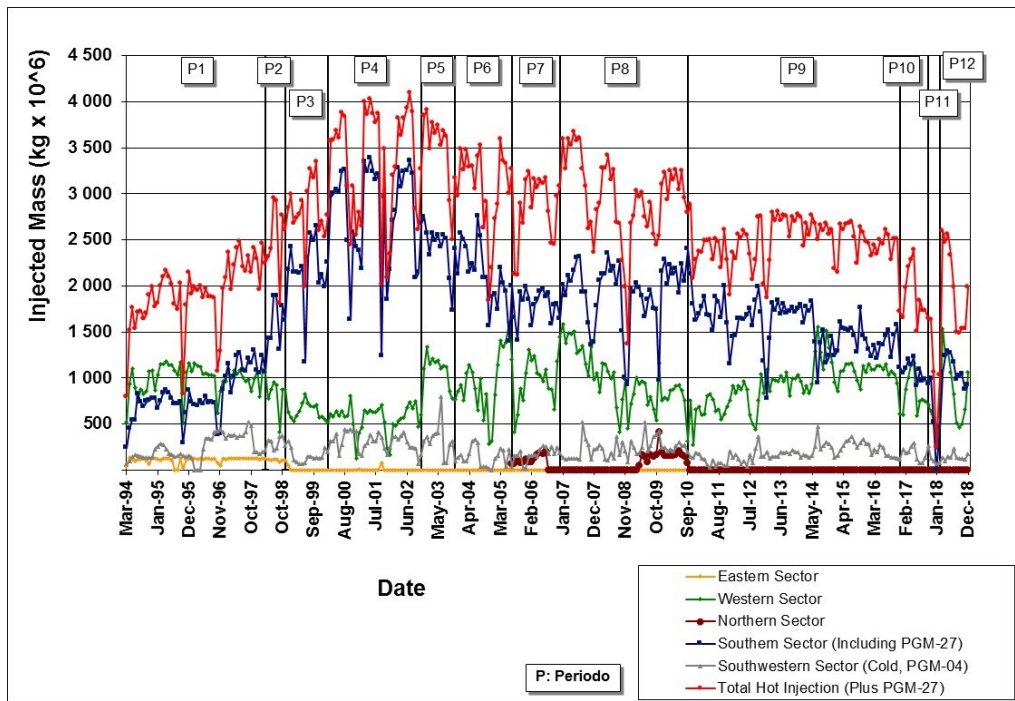

Figure 21: Field-Wide Injection Sector at the Dr. Alfredo Mainieri Protti Geothermal Field.

2.2.6 Cumulative Injection by Well

The cumulative injection per well can be seen in Figure 22. The majority of the brine produced at the Dr. Alfredo Mainieri Protti geothermal field has been injected in the western (PGM-22, PGM-24) and southern (PGM-04, PGM-16, PGM- 26 and PGM-56) sectors of the field. The effect on the reservoir pressure due to extraction and injection is addressed in the next section.

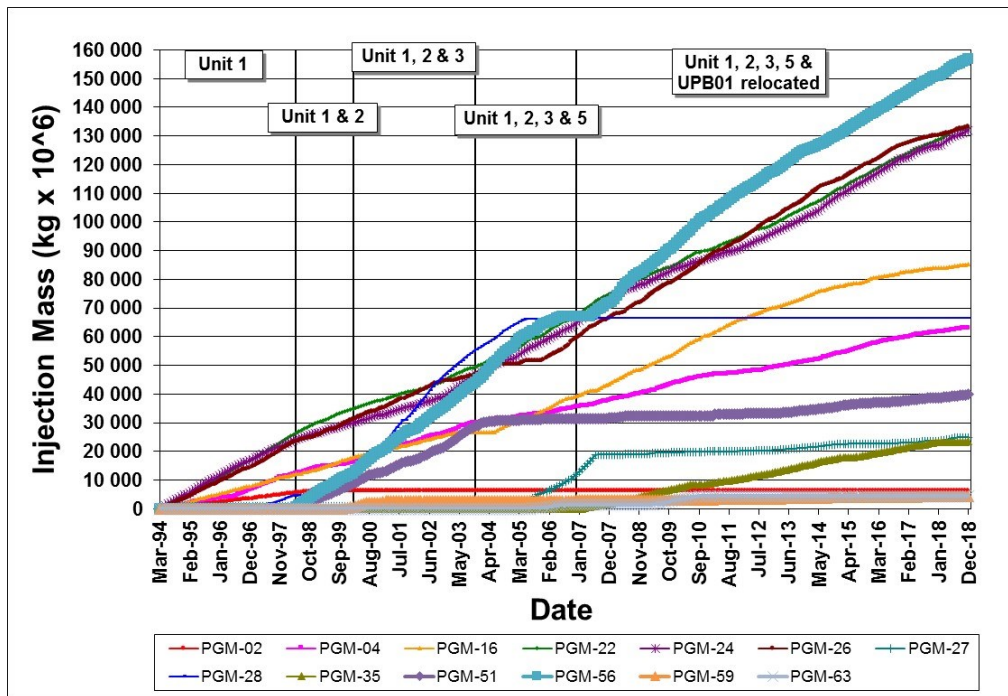

Figure 22: Cumulative Injection by Well at the Dr. Alfredo Mainieri Protti Geothermal Field.

**2.3 Some related remarks with Monitoring and Action Plans**

The Dr. Alfredo Mainieri Protti Geothermal Field is in a complex context. Studies have shown pressure drops, changes of geochemistry, temperature variations in wells, among others (Castro et 2013). At the same time, there are increases in the content of gases in the steam, which have affected the performance of generating units.

Figure 23 shows some examples of changes in the geochemistry and content of gases of some typical cases, with the respective reported decreases in temperatures. The green curve corresponds to chlorides (secondary axis), and the blue curve corresponds to the contents of gases (main hub). PGM-08, PGM-11 y PGM-31 wells have a tendency to increase of chlorides, which could be influenced by injection; nevertheless, only the well PGM-08 has a slight increase in the content of gases; the other two wells tend to decrease.

In the case of the wells PGM-12, PGM-20 and PGM-44, the chlorides decreased (no influence of hot injection). In addition, an increase in gas content was seen. However, for the wells under analysis in that period, there were decreases in temperatures.

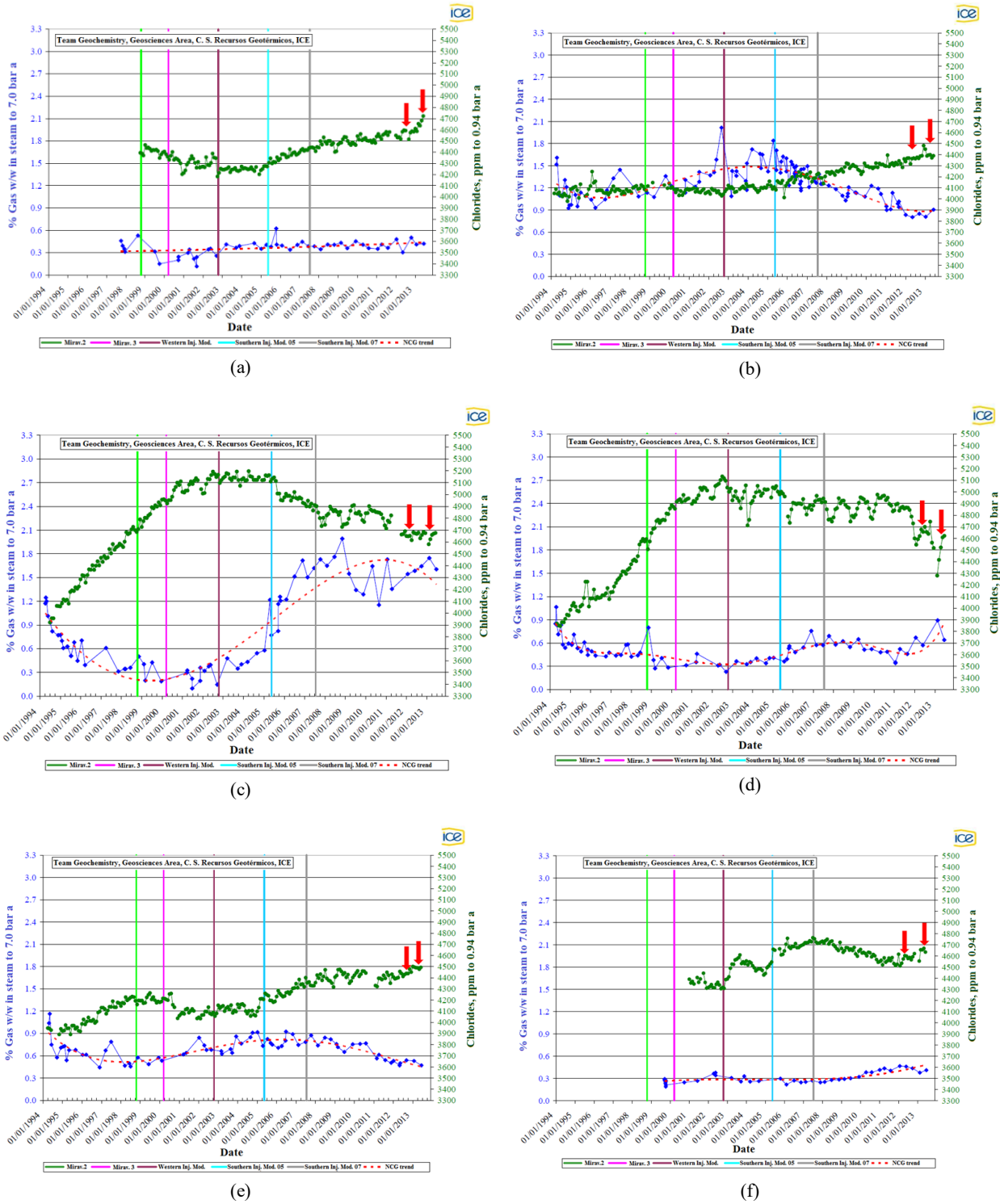

Figure 23: Evolution of non-condensable gases (NCG) and chlorides at some wells of Miravalles Geothermal Field (Chavarría and Torres, 2013): a) PGM-08 (-6 °C), b) PGM-11 (-7.5 °C), c) PGM-12 (-6 °C), d) PGM-20 (-9.2 °C), e) PGM-31 (-6.5 °C), f) PGM-44 (-7.2 °C).

Fluids of hot injection have been sent to other areas in order to compensate adverse effects. These changes are been monitored continuously in order to verify decreases in the rate of decay of thermal and pressure. In addition, it proceeds with load reduction policies in rainy seasons, in units 1, 2 and 5, to reduce the exploitation of the areas most affected.

Until the year 2000, the seismicity of the geothermal field was low, less than 25 earthquakes a year. However, from the year 2001, the seismicity has been increasing year after year, and increased considerably from the year 2005. The year 2010 was the most active of the geothermal field, and the increase in seismicity coincided with a decrease in the total mass injected from August 2010. The 2011 was characterized by a decline in activity, although it was the second most active year. The number of earthquakes decreased from 2012 to 2018, exception 2016 (well-drilling activities could affect). Figure 24 shows the number of earthquakes recorded per year since 1994 to 2018 and Figure 25 shows a map of the Complete Bouguer of the Dr.Alfredo Mainieri Protti geothermal field with microseismicity recorded from 1994 to 2015.

There is a relationship between the increase of seismicity and the decrease in the total mass injected, especially after August 2010. Since August 2010, seismicity peaks occur practically in the same month for the following years. A possible explanation may be associated to periods of low load, as well as the maintenance periods. Since August 2010, seismicity peaks occur practically in the same month for the following years. A possible explanation may be associated to periods of low load, as well as the maintenance periods. When production is diminished during these periods, there is an increase in seismicity, possibly due to the thermal effect and hydro-fracturing that exerts the re-injected water and the same exploitation of the deposit. This complex relationship between injection and the seismicity affects the pressure of pore of the fractured environment and generates a volumetric exchange system, which leads to destabilize the field of efforts by a slight period of time. Once the normal production - injection activity is established, the balance is reached again when water is injected above 800 000 tons/month in the West and 1 500 000 Ton/month in the southern part of the field (Taylor, 2014).

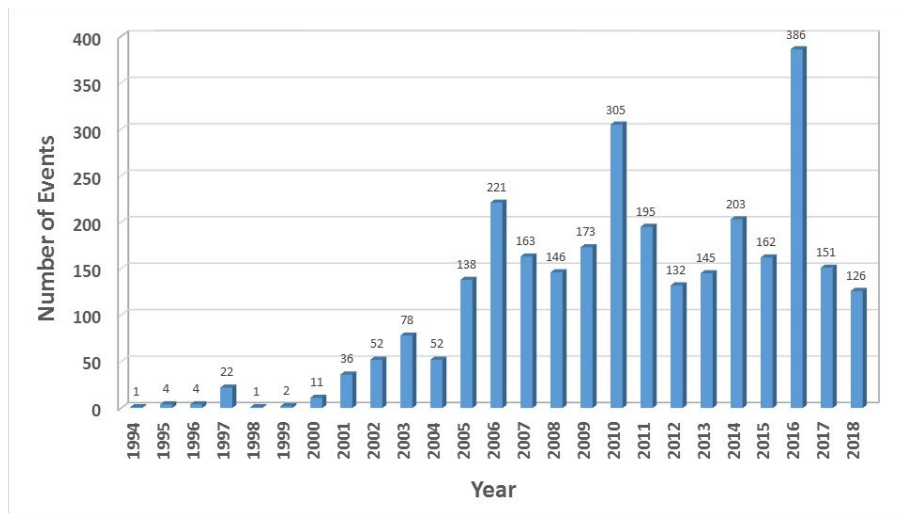

Figure 24: Annual Seismicity recorded at Dr. Alfredo Mainieri Protti Geothermal Field, between 1994 and 2018 (Bakkar and Taylor, 2019)

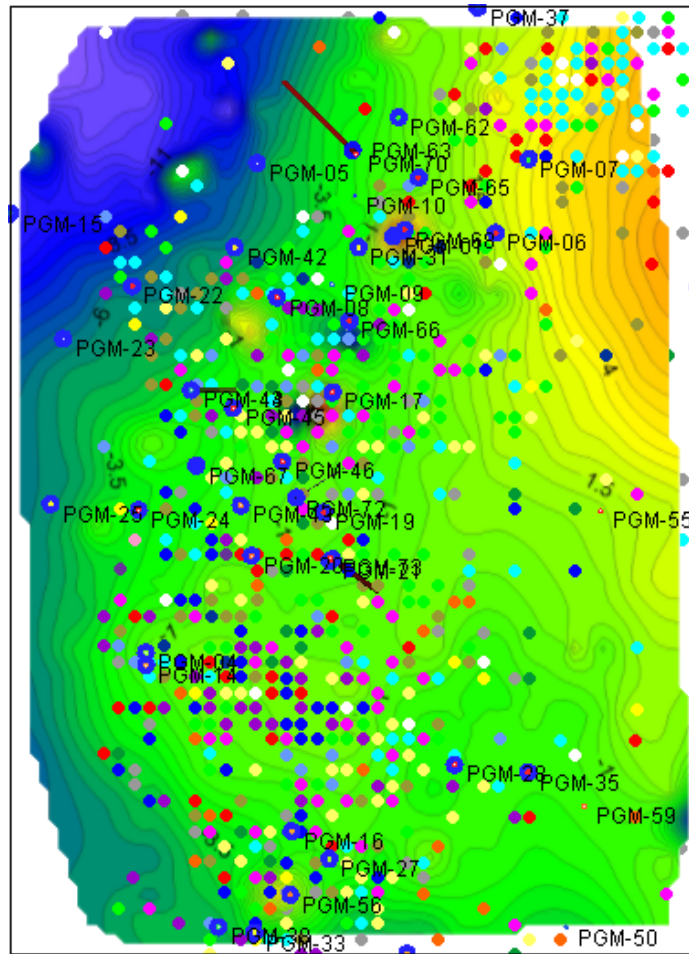
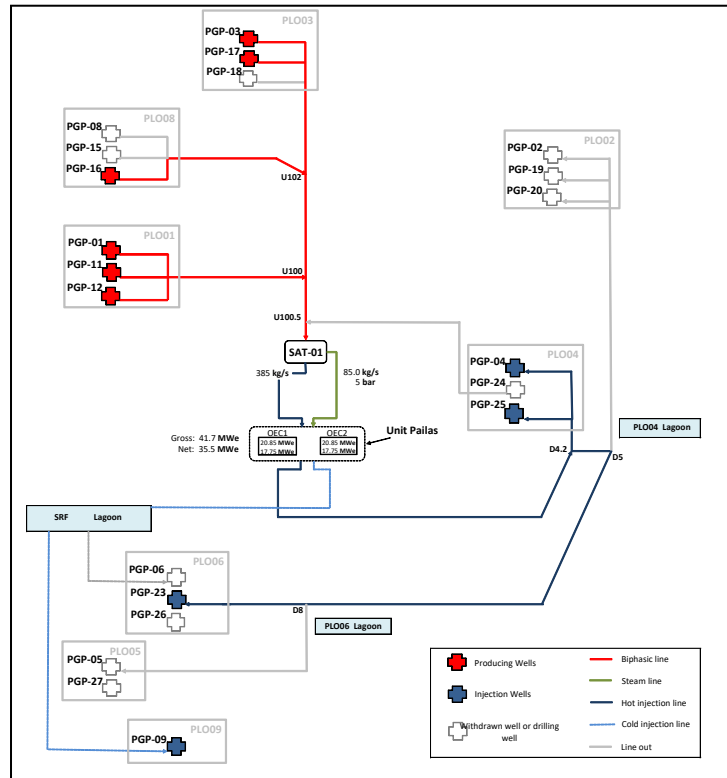

Figure 25: Complete Bouguer map of Dr.Alfredo Mainieri Protti Geothermal Field (blue for lower mgal values and orange for high mgal values) with recorded microseismicity between 1994 and 2014 reported by the OSIVAN-ICE. Color dots represent different years. (Solis, 2015)

### 3. PAILAS GEOTHERMAL FIELD

#### 3.1 Production

In the Pailas geothermal field (Pailas I) there is only a Separation Station, which can separate 90 kg/s of steam and 385 kg/s of brine. This station sends the fluid in its entirety to the Binary Unit. Currently, the station delivers about 85 kg/s of steam (content of gases of 0.08% w/w) and 384 kg/s of liquid, to generate 35 MWe (42 MWe gross). Figure 26 shows a diagram at Pailas Geothermal Field distribution, which details: wells (PGP), squares-pads (PLO), Separation Station, lagoons, Unit, lines and others.



**Figure 26: Diagram at Pailas Geothermal Field (Pailas I).**

In the beginning, the Separation Station was fed by Wells in the PLO-01 squares (PGP-01, PGP-11 and PGP-12 wells), PLO-03 (PGP-03 and PGP-17 wells) and PLO-08 (PGP-08 well). Several wells were made with technology of directional drilling; in order to locate more productive areas, reduce the surface facilities and access to limited surface areas (national parks or reserves). During the starting up, the well PGP-24 (square PLO-04) was integrated for three days; nevertheless, it was closed because there was enough resources in other wells. Eventually, the well PGP-11 was losing productivity, so it was withdrawn in July 2013, opening up sporadically in later months (e.g. October 2013, March and April 2014), to support production. The well PGP-24 was not possible to integrate; tests were carried out (in August 2011 to October 2011) where it verified pressures and low flows, not permissible for the integration into production. The injection in the wells PGP-04 and PGP-25 directly affected the productive capacity of the well PGP-24. The three wells are located in the same square PLO-04. As mitigation, it proceeded with the drilling, testing and integration of a new well, the PGP-16, located in the square PLO-08, and with the withdrawal of the well PGP-08 (October 2013). The PGP-16 gives the support needed in production.

However, other wells have declined in production, such as PGP-11, withdrawn in December 2014. Figure 27 shows the behavior of mass production at the time. Even though they have been removed wells and integrated others, the mass balance decreases over time, reducing the generation of the Pailas I unit. On average, there is a production of 180 000 tons/month of steam and 700 000 Ton/month of brine.

Currently, the separation station has wells located in the squares PLO-01 (wells PGP-01 and PGP-12), PLO-03 (wells PGP-03 and PGP-17) and PLO-08 (well PGP-16).

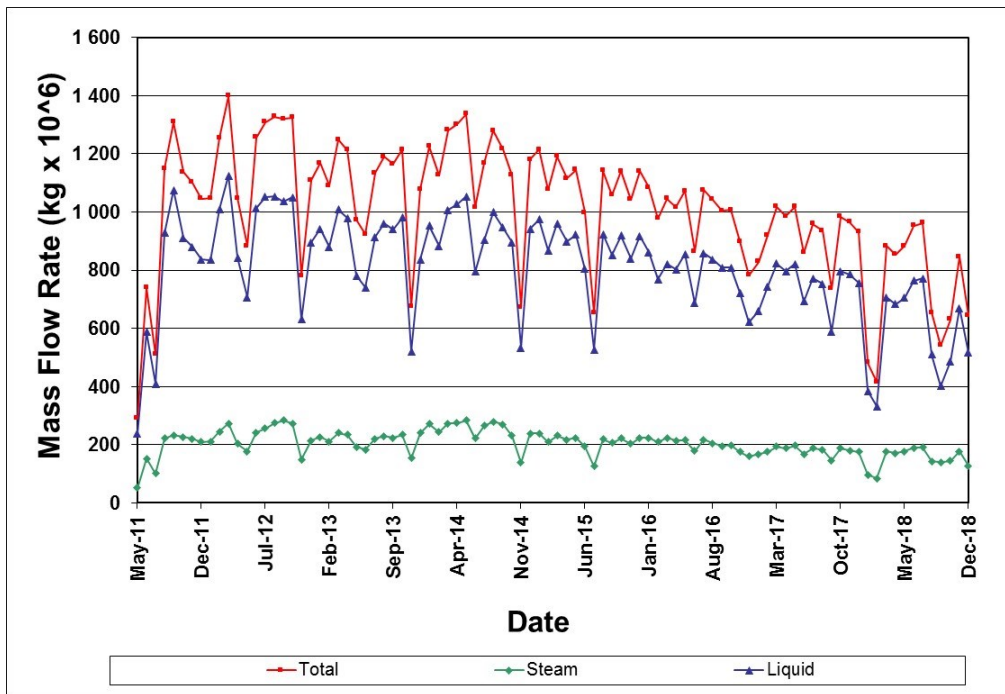

Figure 27: Mass flow rates in the Pailas Geothermal Field (Pailas I).

### 3.2 Injection

For the Pailas field (Pailas I), the disposal of liquids (condensate, brine, and others) is being analyzed in two groups, cold injection and hot injection. In cold injection, the condensed water and other liquids from the main catchment lagoon are sent to two injecting wells (generally, in the furthest well of the field, the PGP-09). Hot injection sends the brine separated from the separator into several injecting wells, two of them located in a same square (PGP-04 and PGP-25, in PLO-04), close to the productive area of the field, a third well located far from the productive area (PGP-23 in PLO-06), and two main wells, PGP-02 (injection from September 2017 to January 2018) and PGP-19 (injection from July 2015 to October 2017), both located in PLO-02.

#### 3.2.1 Cold Injection

The liquid from the main lagoon is injected in two injecting wells, the PGP-09 (in the furthest square of the field, PLO-09). The capacity of injection of each well is low, about 15 - 18 kg/s. Therefore, it is essential to keep a strict control on levels of the lagoon and potential sources of liquid.

As can be seen in Figure 28, this type of injection is in variable over time. Primarily initiated in the well PGP-06, followed by the well PGP-23, followed by the PGP-23 well (by the side of cold injection), located both on the same square (PLO-06); However, once enabled the well PGP-09 (farther from the field), it proceeds with the withdrawal of the wells PGP-06 and PGP-23 (the latter currently only operates in hot injection). Both wells PGP-06 as the PGP-09 operating simultaneously when levels are high in lagoons. There are other wells which have been used in cold injection; these wells were fed with water from lagoons during production tests of other wells.

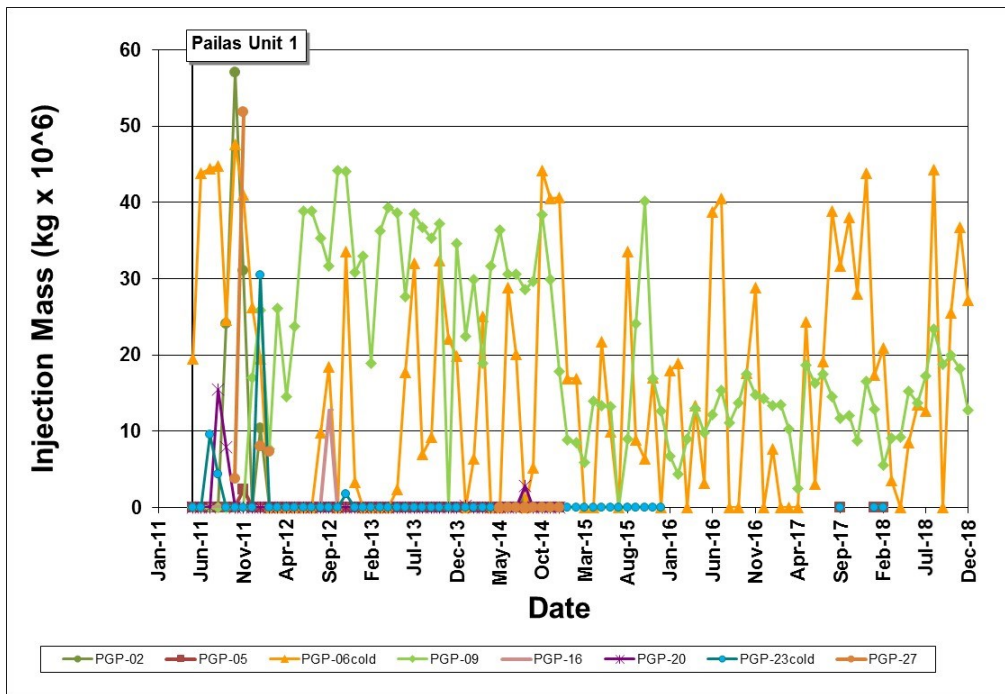

Figure 28: Cold injection at the Pailas Geothermal Field (Pailas I).

3.2.2 Hot Injection

The brine from the Separation Station Pailas I is sent to the hot injection. The brine, previous to be injected, transfers energy in the Pailas Binary Unit, reducing the temperature of injection. At the beginning, the fluids were sent directly to three re-injecting wells, PGP-04, the PGP-25 (both located in the same square in PLO-04) and PGP-23 (located in the PLO-06 square, far from the field). Hot injection in the well PGP-06 was for few days (September 2014). Subsequently, the injection was integrated into PLO-02, mainly in PGP-02 and PGP-19, reducing fluids in the other platforms.

Figure 29 shows the behavior of the hot injection, in the time. Since the beginning, the greater amount of water is injected into the square in PLO-04 (PGP-04 and PGP-25), about 375 000 Ton/month in each well; however, from May 2013 the relationship of injection changes increasing the fluids toward the well PGP-04 and declining slightly in the PGP-25. However, this phenomenon goes hand in hand with injection in the well PGP-23, which began to decrease from October 2012, from 275 000 to 65 000 Ton/month in the months near December 2014, stabilizing in 50 000 Ton/month later (near December 2018). Well PGP-23 is losing injection capacity over time. In November 2016, the injection was reduced in PGP-04 and increased in PGP-25, reversing the pattern. Months before, it proceeded with the injection in the PGP-19 (July 2015 - October 2017) and later in the PGP-02 (September 2017 - January 2018).

By the phenomena presented in the producing wells to inject in the area of the PLO-04, it displays using other wells for hot injection, as the PGP-02 and the PGP-19, both located in a square far away from the field (PLO-02). However, this injection must be done by pumping, because it is located at higher elevation than the Unit.

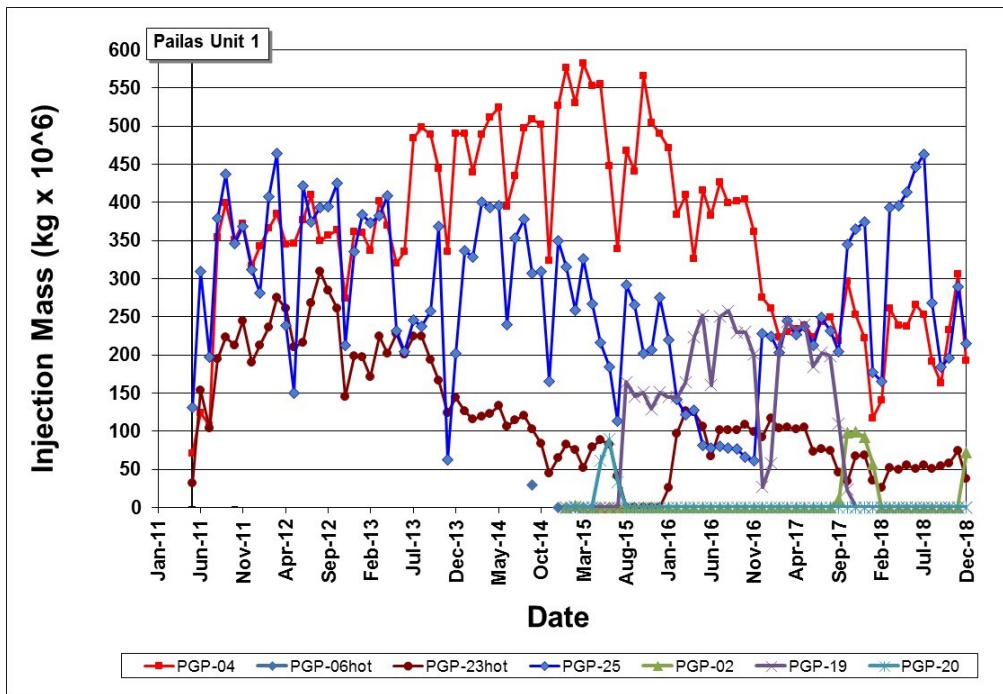

Figure 29: Hot injection at the Pailas Geothermal Field (Pailas I).

**3.3 Some related remarks with Monitoring and Action Plans**

As it has been mentioned in previous sections, there is a direct connection between the hot injected fluids and the production fluids in several wells, some to a greater degree than others, in time of arrival of fluids of injection and in quantities. Both pressure profiles of temperature, as well as also aspects of changes in the chemistry of the fluid, confirm effects of injection. According to studies of chemical tracers (Solis, 2012 and Torres, 2014), injection from the well PGP-25 well, had a direct impact on the PGP-24, and to a lesser extent in the PGP-11 (answers in short times, but in small quantities according to Torres, 2014).

A geophysical model has been developed by the Geophysical Geothermal Group (Solis, Herrera and Guevara, 2014) and later updated by Solis (2017). A general image of the model is presented in Figure 30. This model suggests direct connections from the main area of injection with the productive zone using magnetotelluric techniques that show anomalies possibly related to tectonic faults.

As actions to implement, is the location of injection in other areas, as in the square PLO-02 (PGP-02, PGP-19 and PGP-20). It would begin with a low amount of brine in order to go to evaluate the effect on the producing area and depending on the results, would increase the quantities. On the other hand, the definition of producing wells of replacement in areas away from the main area of production is displayed. A third option suggested by Solis (2017) might be analyzed, related to redistribute part of the reinjection fluids into various wells (in or near the production areas), at low rate at greater depths than nowadays production wells (eg at 3500m depth) were higher temperature and low permeability might contribute to supply more energetic fluids without NGC at the shallow production zones.

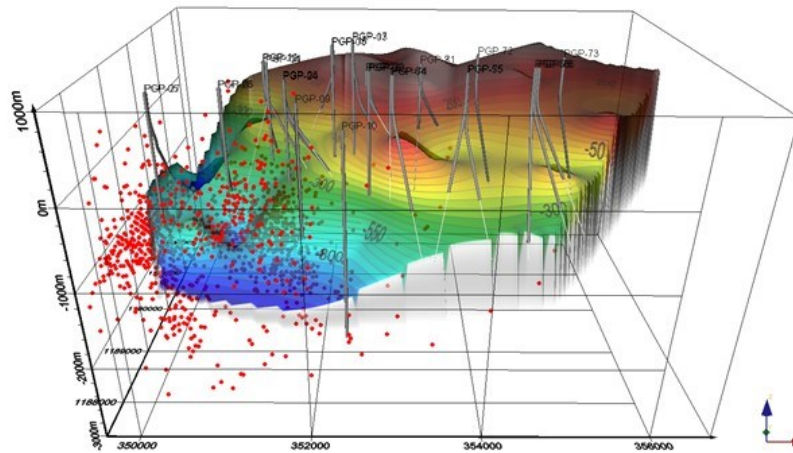

(a)

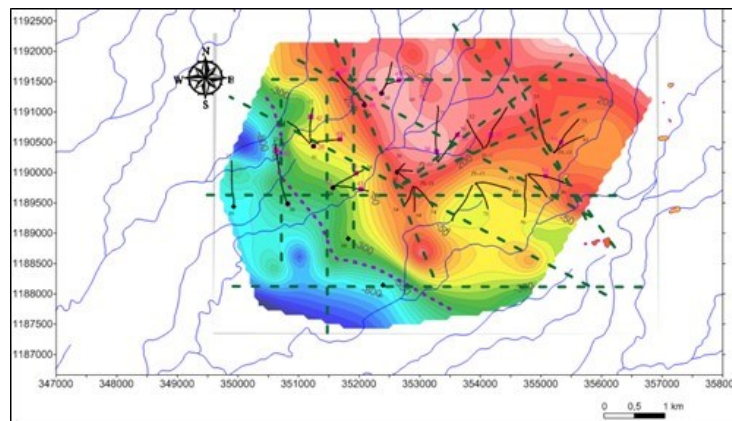

(b)

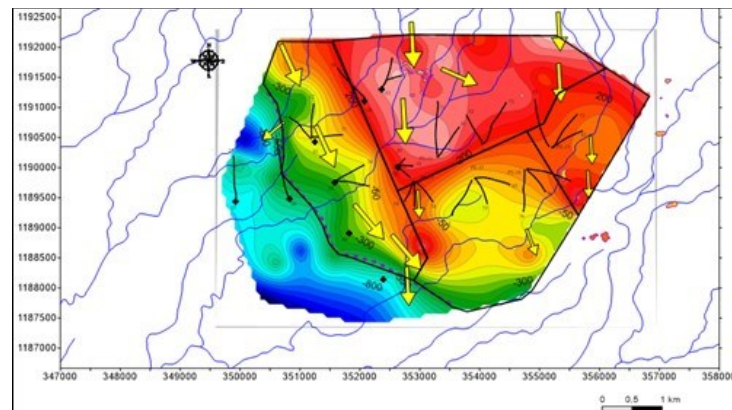

(c)

Figure 30: Model at the Pailas Geothermal Field. These images show: a) 3 D model of the MT cap rock and wells showing microseismicity clusters related to low permeability and fractures response, while testing wells at the west boundary of Las Pailas geothermal field, with great correspondence with the MT cap rock deepening. b) Map shows Pailas I and II geothermal areas, with some interpreted structures from MT and seismic data, as background the contour layer of the MT cap rock. c) The image shows the contour of the geophysical cap rock, some compartments are suggested based on the behavior of the cap rock and yellow arrows suggesting the natural flow direction according to MT and magnetometric analysis. West arrows have excellent correspondence with the results of the tracer tests carried out by Torres (2014) and the cooling of the PGP-11 and PGP-25.

#### 4. FINAL REMARKS

Dr. Alfredo Mainieri Protti Geothermal field maintains a relatively constant production over time, in order to preserve the generation capacity in the Units. Some wells have been closed by decay in productivity and new wells have been integrated into production. Changes are envisaged in the flow regimes (liquid flows decrease, steam flows increase, total mass decreases), as well as variations in pressure drops, thermal changes, changes in geochemistry, seismicity, among others. The field has been exploited for 25 years, with an increasing rate of extraction in the first 10 years, and stabilizing-declining in the last 15 years. The field has produced an approximate total mass of 996 519 866 Tons, between March 1994 and December 2018. Injection was about 796 707 850 Tons of hot brine (hot injection) and 67 320 282 Tons of cold water (cold injection) during this period.

In order to maintain the capacity of Dr. Alfredo Mainieri Protti Geothermal Field, have been identified operating policies to reduce the exploitation of the deposit during the rainy season, when the hydroelectric generation units can reach the maximum capacity. At the same time, fluids injected into other areas (such as the Western) have been reoriented in order to conserve the pressure in the system. Also wells have been drilled, looking for deeper production areas. Favorable results have been obtained.

The Pailas geothermal field (Pailas I) starts the production of fluids continuously in order to keep the generation of the binary plant 35 MWe (42 MWe gross), but now, the generation was reduced to 30 MWe (34 MWe gross) due to the decrease in production. However, short periods of low load, related to maintenance of plant are displayed. They have been extracted about 93 014 948 tons of total mass, and has been injected approximately 74 313 010 tons of brine (hot injection) and 3 505 155 tons of liquid fluid (cold injection), between May 2011 and December 2018. During this period, there have been changes in production and injection wells capacity. Connections between the productive zone and Reinjection area have been demonstrated through geoscientific studies which indicate they are in some cases direct. Replacement wells, as well as changes in other areas of injection among other possible strategies are being analyzed.

#### REFERENCES

- Bakkar, H. and Taylor, W.: Datos de Número de Eventos con respecto a los años, *Internal communication*, Guanacaste, Costa Rica, Jan (2019).
- Castro, S., Chavarría, L. González, C. and Torres, Y.: Perfiles D y E 2013 \_caida de temperatura\_ Jul-13, *Internal report*, Guanacaste, Costa Rica, (2013)
- Cataldi, R. and Mainieri, A.: Geothermal Ranking and Resource Assessment of Costa Rica. Dirección Planificación-Recursos Geotérmicos, *Report*, San José, Costa Rica (1995).
- CENCE: Gráficas Mensuales – Sistema Eléctrico Nacional, Octubre 2018, *Report*, Centro Nacional de Control de Energía, San José, Costa Rica (2018).
- Chavarría, L. and Torres, Y.: Gráficos Geoquímicos de Cloruros, GNC y SO<sub>4</sub> de Miravalles, Revisión de datos geoquímicos y termohidráulicos Miravalles : PGM-08, PGM-11, PGM-12; PGM-20, PGM-31 y PGM-44, *Internal report*, Guanacaste, Costa Rica, (2013).
- Foro: Alfredo Mainieri, padre de la Geotermia en Costa Rica, *forum*, La Nación, San José, Costa Rica (2013).
- G Sistema: Informe de desempeño de los procesos para la Revisión por la Dirección - Área de desarrollo y explotación de yacimientos geotérmicos, *Report*, Guanacaste, Costa Rica (2018).
- Mainieri, A. : Costa Rica country update report, *Proceedings*, World Geothermal Congress 2005, Antalya, Turkey, 24-29 April (2005).
- Nietzen, F. : Informe de Producción y Generación 2008, del Complejo Geotérmico Miravalles , *Internal report*, Guanacaste, Costa Rica, March (2009).
- Nietzen, F. and Solis, L.: Production-Injection at the Costa Rica Geothermal Fields: Miravalles and Pailas, *Proceedings*, World Geothermal Congress 2015, Melbourne, Australia, 19-25 April (2015).
- Solis, L.: Avance prueba de trazadores en Las Pailas 2012, *Internal report*, Guanacaste, Costa Rica, May (2012).
- Solis, L.: Geophysical Information Third Update CG Las Pailas y Unidad 2 Campo Geotérmico Las Pailas, *Internal report*, Guanacaste, Costa Rica, May (2017).
- Solis, L.: Factibilidad para determinar la viabilidad de construir un pozo geotérmico vertical profundo para el manejo de fluidos de reinyección. (2018). [https://www.researchgate.net/publication/329307472\\_FACTIBILIDAD\\_PARA\\_DETERMINAR\\_LA\\_VIABILIDAD\\_DE\\_CONSTRUIR\\_UN\\_POZO\\_GEOTERMICO\\_VERTICAL\\_PROFUNDO\\_PARA\\_EL\\_MANEJO\\_DE\\_FLUIDOS\\_DE\\_REINYECCION\\_2018](https://www.researchgate.net/publication/329307472_FACTIBILIDAD_PARA_DETERMINAR_LA_VIABILIDAD_DE_CONSTRUIR_UN_POZO_GEOTERMICO_VERTICAL_PROFUNDO_PARA_EL_MANEJO_DE_FLUIDOS_DE_REINYECCION_2018)
- Solis, L., Herrera, D. and Guevara, R.: Vistas del modelo conceptual del Campo Geotérmico Pailas, *Internal communication*, Guanacaste, Costa Rica, May (2014).

Nietzen and Solis

Taylor, W.: Sismicidad en los alrededores del Campo Geotérmico Miravalles en el 2013, *Internalreport*, Guanacaste, Costa Rica, May (2014).

Torres, Y.: Avance prueba de trazadores en Las Pailas 2014, *Internalreport*, Guanacaste, Costa Rica, May (2014).