

FRACTAL CHARACTERIZATION OF SUBSURFACE FRACTURE NETWORK FOR GEOTHERMAL ENERGY EXTRACTION SYSTEM

K. Watanabe and H. Takahashi

Research Institute for Fracture Technology
Faculty of Engineering, Tohoku University, Sendai 980, Japan

ABSTRACT

As a new modeling procedure of geothermal energy extraction systems, the authors present two dimensional and three dimensional modeling techniques of subsurface fracture network, based on fractal geometry. Fluid flow in fractured rock occurs primarily through a connected network of discrete fractures. The fracture network approach, therefore, seeks to model fluid flow and heat transfer through such rocks directly. Recent geophysical investigations have revealed that subsurface fracture networks can be described by "fractal geometry". In this paper, a modeling procedure of subsurface fracture network is proposed based on fractal geometry. Models of fracture networks are generated by distributing fractures randomly, following the fractal relation between fracture length r and the number of fractures N expressed with fractal dimension D as $N = C \cdot r^{-D}$, where C is a constant to signify the fracture density of the rock mass. This procedure makes it possible to characterize geothermal reservoirs by the parameters measured from field data, such as core sampling. In this characterization, the fractal dimension D and the fracture density parameter C of a geothermal reservoir are used as parameters to model the subsurface fracture network. Using this model, the transmissivities between boreholes are also obtained as a function of the fracture density parameter C , and a parameter study of system performances, such as heat extraction, is performed. The results show the dependence of thermal recovery of geothermal reservoir on fracture density parameter C .

INTRODUCTION

Recently, HDR (Hot Dry Rock) and HWR (Hot Wet Rock) have attracted considerable attention as new geothermal energy extraction systems. In order to evaluate the performance of these systems, it is necessary to establish a modeling procedure of fluid flow and heat exchange in fractured rock.

Traditionally, models of ground water flow have used parallel fractures, or a continuum approximation such as a "permeable zone". Such models are often

valid when a representative volume of rock can be defined that is much smaller than the region of interest. However, it has been becoming difficult to approximate the behavior of geothermal reservoirs by such models. In fractured rocks, ground water flow and solute transport occur predominantly through the connected network of discrete fractures. For the performance evaluation of such geothermal energy extraction systems, interest has grown in more direct models of water flow and heat exchange in fractured rock.

Recent geophysical investigations have confirmed that a subsurface fracture network can be described by fractal geometry. In the field of seismology several reports are available which have characterized subsurface fractures and fault systems based on fractal geometry. Hirata [1989] has investigated several fault systems in Japan, and characterized them by fractal geometry. In his paper, fractal geometry was considered as a useful tool to characterize the geometry of the fault line. The fractal dimensions of those fault systems were calculated by the so called "box-counting method". Furthermore, Meredith [1990] has noted that subsurface fractures could also be characterized by using a methodology in which the number of fractures was related to the fracture length.

In this paper, two and three dimensional modeling procedures of subsurface fracture network are proposed, based on the relationship between the fracture length and the number of fractures as reported by Meredith. The importance of the parameter is discussed to describe the fracture density of rock mass. This procedure is attractive, since this parameter can be measured from field data such as the core sample, and it is also possible to characterize subsurface fracture network by the same parameter.

For geothermal energy extraction systems, the transmissivity and changes in temperature of geothermal reservoir are important. So, based on this modeling procedure, the transmissivity are discussed in terms of probabilities. Finally, we present one of the results of changes in temperature at reservoir outlet as computed by our model, which suggests the strong dependence of temperature change on fracture density.

FRACTAL DISTRIBUTION OF FRACTURE LENGTH

Fractal geometry is a branch of mathematics that has lingered in the realms of theoretical geometry since the last century. Mandelbrot [1983] realized its great potential for characterizing and simulating the geometry of complex shapes, especially the shapes of nature. The shapes which can be explained by fractal geometry have two important properties. Firstly they have self-similarity. Secondly they are characterized by their fractal dimension.

In nature, there are several irregular shapes which can be explained by fractal geometry. The geometry of subsurface fractures is one of the typical example of such shapes. Hirata [1989] has shown that subsurface fractures such as fault systems can be explained by fractal geometry and he computed the fractal dimensions of several fault systems in Japan. Usually, the fractal dimensions of subsurface fractures or fault systems signify the spatial distribution of fractures. These kinds of fractal dimensions are calculated by the "box-counting method".

Meredith [1990] has reported the investigation of the relationship between the fracture length and the number of fractures. He used the data of several scale fault systems shown in Figure 1.

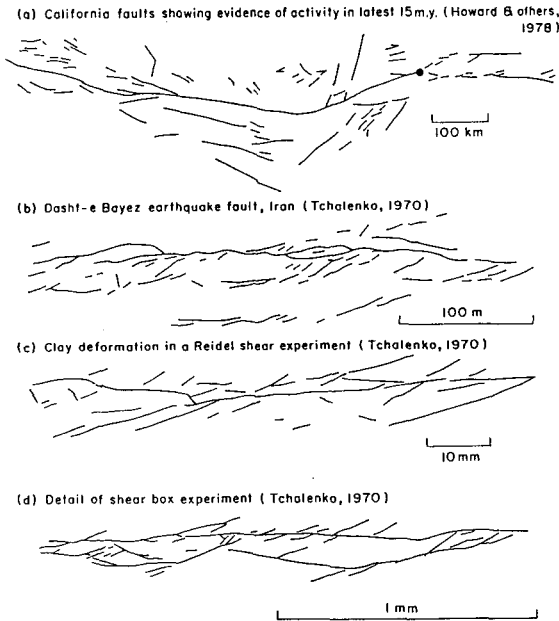

Figure 1 Geometry of fracture system over a range of scales, after Shaw & Gartner [1986].

Figure 2 shows the relationship between the normalized fracture length and the number of fractures. This

revealed that the relation between fracture length r (in his paper, fracture length is represented by the symbol L) and the number of fractures N whose lengths are equal to or larger than r can be expressed by the following fractal equation :

$$N = C \cdot r^{-D} \quad (1)$$

where C is a constant and D is the fractal dimension. The parameter C signifies the fracture density of rock mass. In this paper, C is defined as the fracture density parameter.

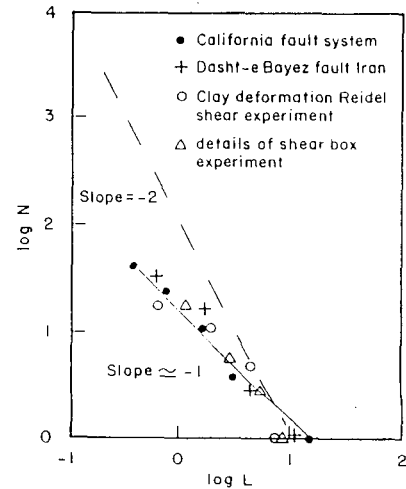

Figure 2 Normalized discrete frequency - length distribution of fracture shown in Figure 1, after Meredith [1990].

Meredith reported that the fractal dimensions were almost equal to 1 for all fault systems he investigated, Figure 1. The meaning of this fractal dimension D is different from that of the fractal dimension calculated by "box-counting method". The former is a measure of the geometry of fractures (branching geometry), while the latter is a measure of the spatial distribution of fractures.

Furthermore, Thomas et al [1989] have investigated the width (opening) distribution of fractures observed on core samples and boreholes. The result showed that the relationship between the fracture width w and the number of fractures whose widths are equal to or larger than w can be also explained by the same formula as Equation (1) and it can be represented by the following equation (although the importance of fracture width distribution is not included here) :

$$N' = C' \cdot w^{-D'} \quad (2)$$

In the modeling procedure proposed here, the models of fracture network are regarded as being composed of discrete fractures. These fractures are distributed to satisfy Equation (1).

TWO DIMENSIONAL NUMERICAL MODEL

1. Characteristic features of individual fractures

For the two dimensional model of subsurface fracture network, imagine the square area of edge length L between boreholes as shown in Figure 3. Within this area discrete fractures are distributed following the fractal relationship between the length and the number of fractures. In other words, the fracture network model is generated in this area by using fractures that satisfy Equation (1). In order to simplify the discussion, the area and the fractures are normalized by the length L as shown in Figure 3.

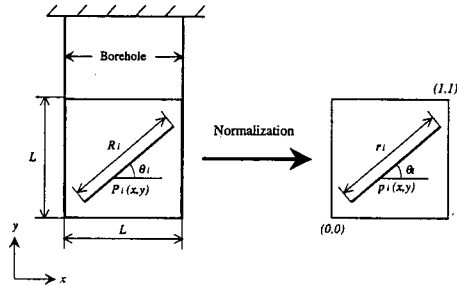

Figure 3 Concept of two dimensional fracture.

In this model, the total number of fractures is expressed by the symbol n , and i th ($i=1,2,\dots,n$) fracture is characterized by the following three parameters: (1) Middle point, p_i , (2) Angle from the horizon, θ_i , (3) Length, r_i . In this paper, these parameters are determined as follows.

(1) Middle point of the fracture, p_i

It is assumed that the fractures do not form a cluster around any point. So, x and y co-ordinates of the point p_i are determined by using random numbers lying between 0 to 1.

(2) Angle from the horizon, θ_i

The distribution of θ_i seems to be random, however field data sometimes shows that there exist preferred directions of fracture orientation. So, if it is possible to obtain the preferred direction, θ_i must be determined to have the same tendency as that of the field data. In this paper, two types of angle distribution are used as examples.

(3) Length of the fracture, r_i

Since the lengths of fractures are ruled by fractal geometry, r_i distribution must satisfy Equation (1). In order to satisfy Equation (1), r_i is determined by the following formula :

$$r_i = (C/i)^{1/D} \quad (3)$$

(4) Total number of fractures, n

Theoretically, if we need to consider very small fractures whose lengths approach 0, n would approach

infinity. However, very small fractures can not be observed, and is dependent upon the resolution of measuring instrument. In this paper, r_{min} is defined as the smallest length of fracture which can be observed. According to the data reported by Meredith [1990], r_{min} is between 0.04 and 0.11. So, we let the value of r_{min} as 0.04, and the smallest i which satisfies $r_i > r_{min}$ as the value of n .

2. Fractal Dimension : D

Although some fault systems have been investigated and their fractal dimensions calculated by the "box-counting method", the fractal dimensions required for Equation (1) are not available. The data from Meredith [1990] is the only published information from which we can obtain the fractal dimension D . Meredith [1990] has measured the relationship between the fracture length and the number of fractures at 4 different scale fault systems and shown that the fractal dimensions of all fault systems are almost equal to 1 as shown in Figure 2. In this present work, we adopt the same value of fractal dimension, i. e. $D=1$.

3. Examples of fracture network model

Figure 4 shows some sample patterns of fracture network model for 3 different values of the fracture density parameter C . Two types of fracture network model are shown. One model has a random distribution of fracture angle (Type 1), the other has two preferred directions (Type 2). Figure 4 illustrates the strong influence of the fracture density parameter C on fracture network patterns.

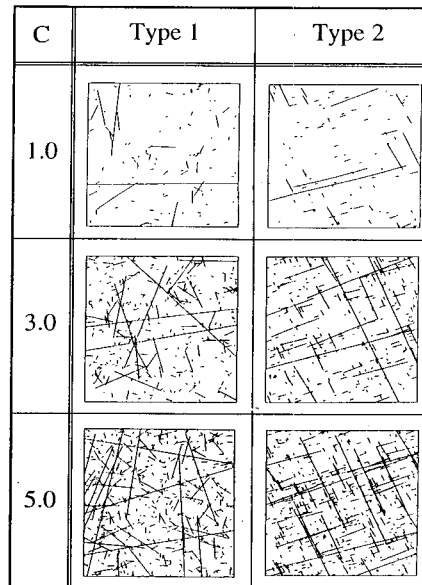

Figure 4 Some of fracture patterns generated numerically based on modeling procedure proposed here.

THREE DIMENSIONAL FRACTURE NETWORK MODEL

For the estimation of practical system performance such as transmissivity and thermal recovery, two dimensional geothermal reservoir model may not be accurate. It is necessary to extend two dimensional modeling procedure into a three dimensional one. However, there is no information about three dimensional shape of subsurface fractures. In this paper, we assume that the subsurface fractures are penny-shaped. Figure 5 shows the concept of three dimensional fracture network model. The network is formed by distributing penny-shaped fractures in the box randomly.

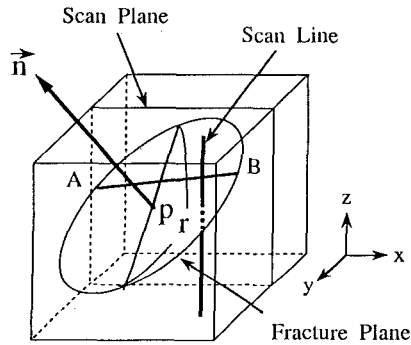

Figure 5 Concept of three dimensional fracture network model.

As in the two dimensional modeling procedure, each fracture is characterized by the following parameters :

- (1) Central point of the fracture : p
- (2) Normal of the fracture plane : \vec{n}
- (3) Diameter of the fracture : r

In this paper, these parameters are determined by following the same way as the two dimensional modeling procedure. Central point and normal of the fracture are determined by random numbers. Diameter of the fracture is calculated by Equation (3).

Figure 6 is a schematic figure of the three dimensional fracture network model.

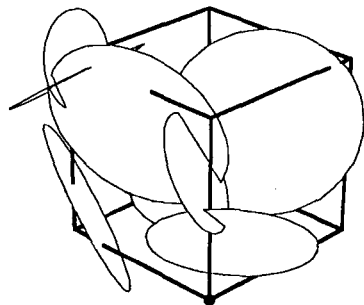

Figure 6 Schematic figure of three dimensional model.

RELATIONSHIP BETWEEN TWO DIMENSIONAL AND THREE DIMENSIONAL MODELS

Length distributions of fractures observed on two dimensional area are fractal. Therefore length distributions of fractures observed on any two dimensional section area of this model must be fractal. Scan planes are introduced to examine fracture pattern and length distribution as shown in Figure 5. Figure 7 shows one of the fracture patterns on a scan plane obtained from three dimensional fracture network model. Figure 8 shows length distributions of fractures on four scan planes randomly chosen from a model ($D=1.8$, $C=5.0$). It is possible to say that the three dimensional model which has fractal length distribution of fractures shows fractal characteristics on its two dimensional sectional areas. The relationship between the fractal dimensions of two dimensional fracture network model and that of the three dimensional model is obtained as shown in Figure 9.

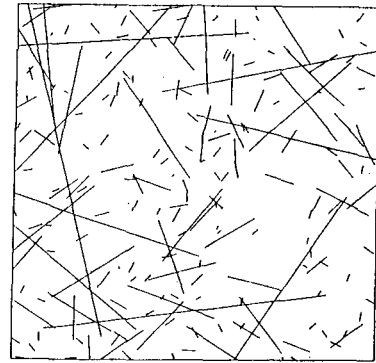

Figure 7 One of the fracture patterns on a scan plane.

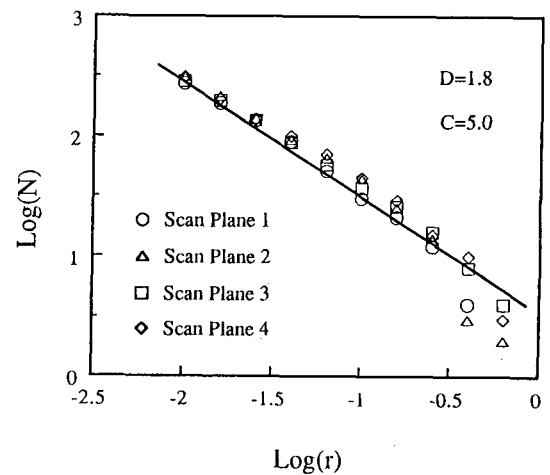

Figure 8 Length distribution of fracture on scan planes.

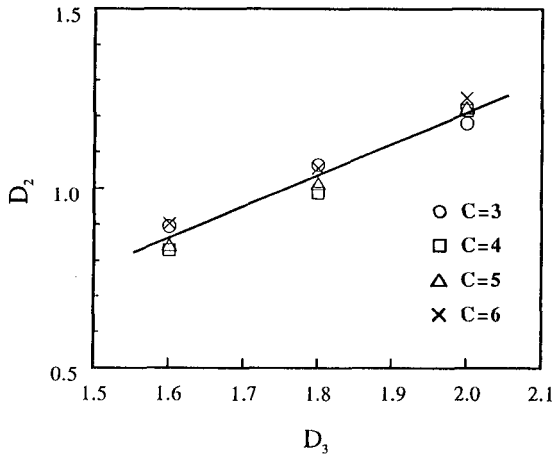

Figure 9 Relationship between fractal dimension of two dimensional model and that of three dimensional model.

ESTIMATION OF THE VALUE OF PARAMETER C

It is possible to measure the number of fractures which are observed on a core sample or borehole per unit length of depth. Considering a borehole as a scan-line of a subsurface fracture network as shown in Figure 5, it is possible to predict the number of fractures observed on core sample per unit length of depth m by the following equation :

$$m = \overline{\sin \theta_i} \cdot \left\{ \int_{r_{min}}^1 \pi \cdot \left(\frac{r}{2}\right)^2 \cdot \left(-\frac{dN(r)}{dr}\right) \cdot dr + C \right\} \quad (4)$$

where $\overline{\sin \theta_i}$ is the average of θ_i . From Equation (4), the fracture density parameter C can be calculated using the following equation :

$$C = \frac{4m}{\overline{\sin \theta_i} \cdot \left\{ 9\pi \cdot (1 - r_{min}^{0.2}) + 1 \right\}} \quad (5)$$

APPLICATIONS

Transmissivity

Transmissivities of fracture network are calculated by using the following equation :

$$k_x \cdot \frac{d^2 P}{dx^2} + k_y \cdot \frac{d^2 P}{dy^2} + k_z \cdot \frac{d^2 P}{dz^2} = 0 \quad (6)$$

where P and Q stand for pressure and quantity of water respectively. k_x , k_y and k_z represent rock mass permeability in each of the x , y , z directions, which are determined by the fractures.

Three types of water flow models used for the calculation are (Figure 10)

- (1) Plane - Plane flow
- (2) Plane - Borehole flow
- (3) Borehole - Borehole flow

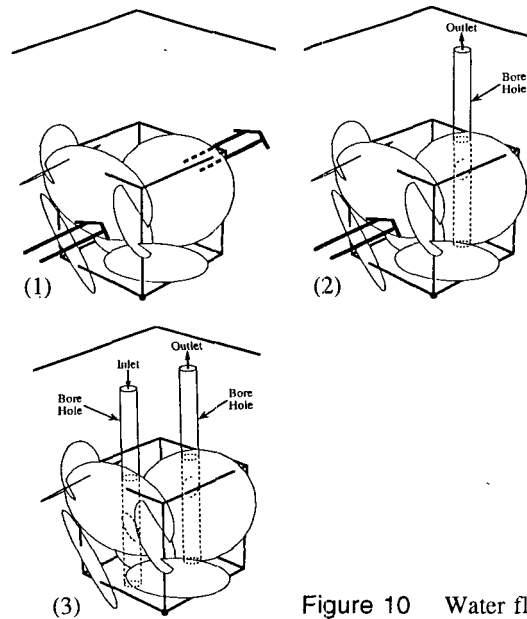

Figure 10 Water flow models.

Figure 11 shows one of the results of the calculation. For this calculation, 100m square reservoir is used and the assumption that the width of the fracture is proportional to its length is adopted.

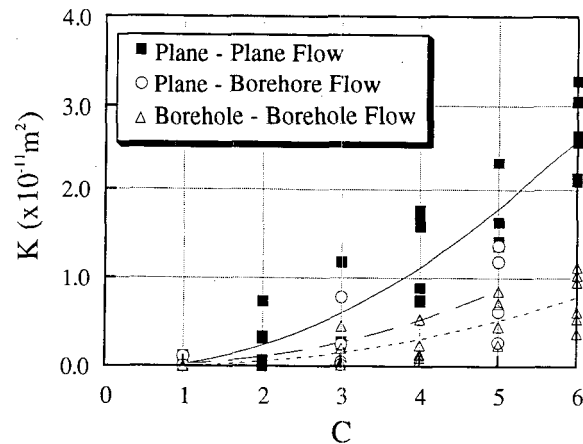

Figure 11 Relationship between parameter C and transmissivity.

Heat Extraction

The change in temperature at the outlet of the reservoir as the time passes is calculated. The model used for thermal calculation is shown in Figure 12.

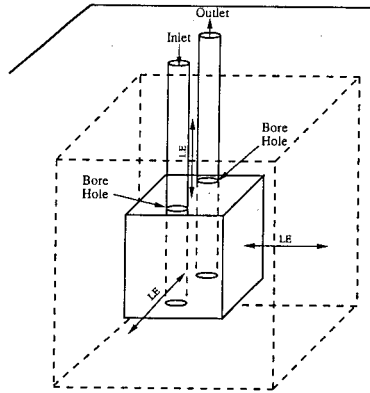

Figure 12 A model used for thermal calculation.

In Figure 12, dashed line expresses adiabatic boundary for thermal calculation and LE represent the distance to the boundary. Equation (7) is adopted for thermal calculation.

$$C_R \cdot \rho_R \cdot \frac{\partial T}{\partial t} + C_W \cdot \rho_W \cdot \left(v_x \cdot \frac{\partial T}{\partial x} + v_y \cdot \frac{\partial T}{\partial y} + v_z \cdot \frac{\partial T}{\partial z} \right) = \lambda \cdot \left(\frac{\partial^2 T}{\partial x^2} + \frac{\partial^2 T}{\partial y^2} + \frac{\partial^2 T}{\partial z^2} \right) \quad (7)$$

where T stands for the temperature of rock (equal to the temperature of water in this paper). λ is thermal diffusivity of rock. C_R and C_W represent specific heats of rock and water, ρ_R and ρ_W represent the densities of rock and water. v_x , v_y and v_z are flow velocities in each of directions.

Figure 13 shows the results of the calculation with following parameters :

- Size of reservoir : 100m cubic
- LE : 100m
- Initial temperature of rock mass : 300 °C
- Temperature of water at outlet : 200 °C

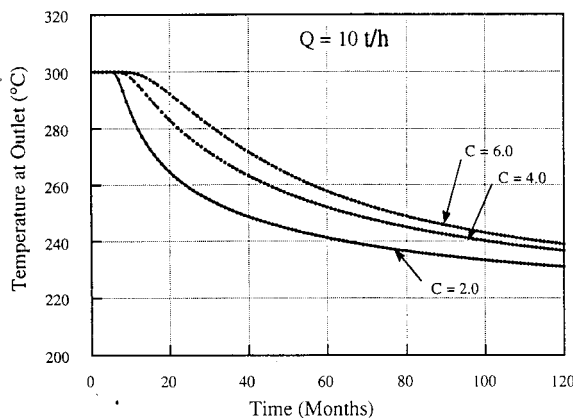

Figure 13 Changes in temperature at reservoir outlet.

In Figure 13 we plot the reservoir outlet temperature versus time by ranging the parameter C which represents the fracture density of rock mass. It can be clearly seen from the graph that there is a strong relationship between the outlet temperature and the fracture density.

CONCLUSION

A modeling procedure based on fractal geometry is quite effective for characterizing subsurface fracture networks. Borehole data have not been used in the past, although it is one of the few datas which contain subsurface information. For this modeling procedure, borehole data gives significant bases for the characterization of geothermal reservoir. Once the model of geothermal reservoir is established, it is possible to predict the transmissivity of fluid path and thermal recovery of geothermal reservoir.

Using the fracture network model proposed here, hydrological and thermal behavior, including long-term performance, of several types of geothermal reservoir can be simulated numerically. This modeling procedure should also make it possible to predict the effectiveness of hydraulically stimulated fractures, since hydraulical stimulation increases the density of fracture in geothermal reservoirs.

REFERENCES

- Gringarten, A. C., Witherspoon, P. A. and Ohnishi, Y., "Theory of Heat Extraction From Fractured Hot Dry Rock", Journal of Geophysical Research, Vol. 80, No. 8, 1120-1124, 1975.
- Harlow, F. H. and Pracht, W. E., "A Theoretical Study of Geothermal Energy Extraction", Journal of Geophysical Research, Vol. 77, No. 35, 7038-7048, 1972.
- Hirata, T., "Fractal dimension of fault system in Japan : Fractal structure in rock fracture geometry at various scales", Pure and Applied Geophysics, Vol. 131, 157-170, 1989.
- Mandelbrot, B. B., "The Fractal Geometry of Nature", Freeman, New York, 1983.
- Meredith, P. G., "Scattering Attenuation and the Fractal Geometry of Fracture System", Pure and Applied Geophysics, Vol. 133, 283-304, 1990.
- Shaw, H. R. and Gartner, A. E., "On the Graphical Interpretation of Palaeoseismic Data", U.S.G.S. Open File Report, 86-394, 1986.
- Thomas, A., Blin-Lacroix., "Stochastic modeling of fractured reservoir", Proceeding of International Hot Dry Rock Geothermal Energy Conference, Camborne School of Mines, 1989.