

## THE MUTNOVSKY GEOTHERMAL POWER PLANT CREATION EXPERIENCE

O. A. Povarov<sup>1</sup>, V. Y. Luzin<sup>2</sup>, G. V. Tomarov<sup>1</sup>, V. M. Morgun<sup>1</sup>, and A. Butovsky<sup>2</sup>

<sup>1</sup>Geotherm SC, Moscow, Russia; <sup>2</sup>Geotherm SC, Petropavlovsk-Kamchatsky, Russia

### ABSTRACT

*The energy development strategy of the Kamchatka Region lies in its entire conversion for use of geothermal resources. The Mutnovsky geothermal reservoir is well-studied and found adequate to ensure the operation of a geothermal power plant with more than 300MW total capacity.*

*The program of construction of the geothermal power plant series at the Mutnovsky steam-field is under active implementation by Geotherm SC. In 1999, a 12 (3x4)-MW Verchne-Mutnovsky geothermal power plant was put into operation, and in 2002, the 1<sup>st</sup> stage of the 50 (2x25)-MW Mutnovsky geothermal power plant was constructed.*

*It is planned to construct the 2<sup>nd</sup> stage of the Mutnovsky geothermal power plant with 100MW capacity and to start works on the creation of the 4<sup>th</sup> geothermal power unit with 4.0-MW capacity utilizing binary cycle at the Verchne-Mutnovsky geothermal power plant.*

### 1.0 INTRODUCTION

Russia possesses a unique reserve of geothermal heat in Kamchatka and Kuril Islands. They are adequate for generation of electric power and heat of more than 2000-MW<sub>e</sub> total capacity.

The first experience of obtaining electric power based on geothermal heat use was gained at the Paratunsky geothermal reservoir (Kamchatka) at Russia in 1967. Geothermal binary two-circuit pilot power plant of about 500-kW<sub>e</sub> capacity (Britvin et al., 2000) was created here for the first time in the world.

In 1967 the industrial production of electric power at the first Russian geothermal power

plant got under way at the Pauzhetsky reservoir (Kamchatka). The installed capacity of the 1<sup>st</sup> stage of the Pauzhetsky Geothermal Power Plant was equivalent to 5 MW<sub>e</sub>, and in 1982 it was brought to 11 MW<sub>e</sub>. Even nowadays the Pauzhetsky Geothermal Power Plant is a sustainable producer of one of the cheapest electric power in Kamchatka (Fig. 1).

In recent years the works on commercializing geothermal power technologies in Russia were liven up. Russian companies Geotherm SC, Nauka SC, and others in cooperation with RAO "EES of Russia" and by financial support of European Bank for Reconstruction and Development and the Savings Bank of the Russian Federation have organized a full-scale production of the equipment (turbo-generators, separators, and others), and implemented the program of developing geothermal power technologies:

- In 1993 the modular geothermal power plant of 700-kW<sub>e</sub> was put into operation in Kunashir island;
- Within 1992-1996 Kaluga Turbine Works SC manufactured 9 geothermal power units of 1.7-4.0-MW<sub>e</sub> capacity;
- In 1993 the first environmental friendly Verchne-Mutnovskaya Geothermal Power Plant (Kamchatka) of 12 (3x4)-MW<sub>e</sub> capacity was commissioned;
- In 2002 the construction of the 1<sup>st</sup> stage of 50 (2x25)-MW<sub>e</sub> Mutnovsky geothermal power plant was completed and its exploitation started.
- The construction of combined IV unit of the Verchne-Mutnovsky Geothermal Power plant with binary cycle of 6.5-MW<sub>e</sub> capacity is underway.



Figure 1. Pauzhetskaya geothermal power plant (11-MWe) operating since 1967.

- The preliminary activities on the creation of the 2<sup>nd</sup> stage of the Mutnovsky geothermal power plant of 100-MW<sub>e</sub> capacity are in progress.

Now in Kamchatka seven geothermal power units of 73-MW<sub>e</sub> total installed capacity are operational. By 2010 it is proposed to construct several geothermal power plants at the Mutnovsky reservoir thereby bringing their total capacity to 300-MW<sub>e</sub>.

## 2.0 THE 1<sup>ST</sup> ENVIRONMENTALLY FRIENDLY VERCHNE-MUTNOVSKY GEOTHERMAL POWER PLANT

The whole equipment of the pilot Verchne-Mutnovsky Geothermal Power plant was developed and manufactured by Russian scientific organizations and factories. SC Kaluga Turbine Works delivered turbo-generators, Podolsky Works SC – separators, and Chekhovsky Works SC of power reinforcement

supplied fittings (Britvin et al., 2001; Kiryukhin, 1996).

The concept in the creation of the Verchne-Mutnovsky Geothermal Power plant was developed given the severe climatic conditions and short summer construction season in Kamchatka:

- it used the unit-modular system of steam preparation delivered under complete factory readiness;
- main unit-modules (of turbo-generators, electrotechnical equipment, main control board, etc.) are delivered being fully assembled and completely tested (Fig. 2);
- technological scheme of Geothermal Power plant allows realizing an environmental friendly use of geothermal fluid (excluding any contact with environment) at the expense of applying air-condensers and re-injection system of the worked out working body.



Figure 2. First environmental friendly pilot Verkhne-Mutnovskaya geothermal power plant of 12 (3x4) MWe capacity.

Two-phase flow from the production wells by pipeworks enters the collector and then, after the two-stage separation system, the saturated steam comes to three power units of 4-MWe capacity each (Fig. 3). Steam pressure at the turbine inlet amounts to  $p_0=0.8$  MPa (at about  $170^{\circ}\text{C}$  temperature). Steam humidity degree is not higher than 0.05% that ensures low content of salts in the turbine steam. To increase the efficiency of geothermal fluid the hot brine is transported to the expander, working at nearly 0.4 MPa pressure. Steam is produced in expander and is used in ejectors to remove non-condensing gases from the condenser. Non-condensing gases are dissolved in absorber in the worked out geothermal fluid, which is further re-injected into the re-injection wells.

Control over three power units is implemented from the main control board module.

At 6-m height from the foundations of the turbo-generators 6 sections of air-condensers with electrical fans, designed and manufactured at

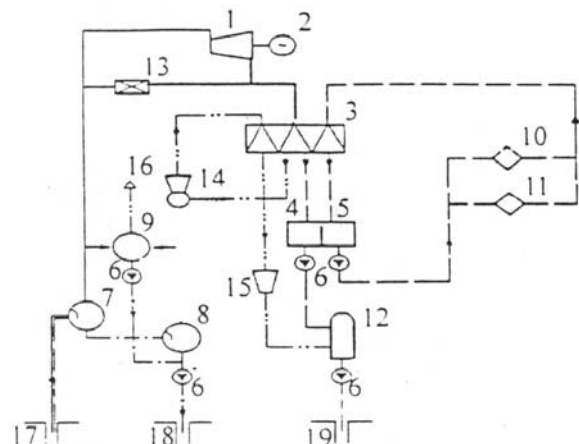

Figure 3. Principal heat scheme of the power unit. (1) turbine; (2) generator; (3) air condensing installation; (4) condensate tank; (5) cooling water vessel; (6) pump; (7) separator; (8) expander; (9) plant silencer; (10) oil cooler; (11) air cooler; (12) absorber; (13) throttle-humidifier installation; (14) ejector installation; (15) liquid-packed compressor; (16) exhaust pipe; (17) production well; (18) brine reinjection well; (19) condensate reinjection well.



Figure 4. The first Mutnovsky geothermal power plant of 50 MWe capacity.

Kaluga Turbine Works SC, are located. Every section of the air-condenser consists of 8 units with steel galvanized tubes, ribbed with aluminium ribbon.

The steam preparation unit (SPU) for the Verchne-Mutnovsky Geothermal Power plant was designed by Nauka SC together with NUZ Geo of Moscow Power Engineering Institute, ENIN, VNIAM, and SNIIEP, and was manufactured at the Podolsky Machine-Building Works SC and the module fully assembled at the factory.

Pumps of the worked out fluid re-injection system, fire-prevention, and auxiliary pumps, electrical control boards as well as the protection system of the Geothermal Power plant working path from corrosion and salt depositions are located in the pump SPU section. While exploiting, the protection system allows removal of the salt depositions in turbines and air condensers, and preventing corrosion during shutdowns.

The turbines for the Verchne-Mutnovsky Geothermal Power plant have several specific distinctions: regulation of the steam consumption at the inlet pipeline is attained with rotary flaps of "butter-fly" type, and the steam exhaust from the turbines occurs vertically upwards. The whole 10 stages of the turbines have external shroud rings to develop moisture separation system.

### 3.0 THE 1<sup>ST</sup> MUTNOVSKY GEOTHERMAL POWER PLANT

The successful completion of the Verchne-Mutnovsky Geothermal Power plant construction, high efficiency, and environmental

purity of geothermal power projects in Kamchatka attracted attention of foreign financial companies, and in 1998 the implementation of International Investment Project on the 1<sup>st</sup> stage of the (50-MW<sub>e</sub>) construction has begun using means of EBRD loan and Russian investors funds.

In November 2002 the 1<sup>st</sup> Mutnovsky Geothermal Power plant was put into operation (Fig. 4). It consists of:

- main building with turbine equipment;
- separator station with pump station;
- cooling-towers;
- combined auxiliary building;
- building with complex gas-insulated switch-gear (220kV);
- electric power delivery equipment;
- treatment facilities, and others.

The steam preparation system ensures geothermal steam supply to the Geothermal Power plant technological scheme with the steam rate around 320 t/hour at 0.7-MPa pressure. The above system of the Geothermal Power plant includes the 1<sup>st</sup> stage separators, silencers, and auxiliary equipment, enabling to obtain steam at the turbine inlet with the humidity degree lower than 0.05% (Britvin et al., 2001).

The conception of the 1<sup>st</sup> stage of Mutnovsky Geothermal Power plant is based on the automated remote regulation and technological process control (Fig. 4).

With the view of ensuring environmental purity, there is a provision of condensate and brine re-injection system back to geothermal reservoir, as well as the systems of H<sub>2</sub>S exhaust and snow-melting prevention.

#### 4.0 COMBINED IV POWER UNIT OF THE VERCHNE-MUTNOVSKY GEOTHERMAL POWER PLANT WITH BINARY CYCLE

Russian experience of the Paratunsky Geothermal Power plant with binary cycle creation and successful exploitation of the Verchne-Mutnovsky Geothermal Power plant since 1999 underlay the project on development of combined IV unit of the Verchne-Mutnovsky Geothermal Power plant with binary cycle, and Geotherm SC and Nauka SC with financial support of RAO "EES of Russia" have commenced its implementation.

Creation of the IV power unit with binary cycle will enable to increase the capacity, reliability, and effectiveness of the Geothermal Power plant on the whole.

Scientific and technical developments of Geotherm SC and Nauka SC for the purpose of creation of the IV combined Verchne-Mutnovsky Geothermal Power plant power unit with binary cycle identified an optimum heat scheme, technological modes, organic working body, and the main equipment structures.

The analysis indicates the following unused at the Verchne-Mutnovsky Geothermal Power plant components:

- exhaust geothermal fluid (hot water) of 140°C temperature;
- 170°C temperature unused geothermal fluid of No. 049 substandard well.

The creation of the 4<sup>th</sup> combined power unit with binary cycle will enable:

1. to increase considerably (more than for 10%) the effectiveness of geothermal fluid potential at the Verchne-Mutnovsky Geothermal Power plant with no additional drilling of wells while utilizing the heat of exhaust and substandard geothermal fluid.
2. to increase the Verchne-Mutnovsky Geothermal Power plant capacity per 6.5-MW<sub>e</sub> (more than per 50%).
3. to raise reliability, fail-safety, and security of the Verchne-Mutnovsky Geothermal Power plant operation under extreme conditions of winter (strong wind – over 40m/sec, hard frost of up to minus 25°C, snowdrifts to

10-m height) at the expense of applying non-freezing (up to minus 140°C) organic working body in the binary cycle of the 4<sup>th</sup> power unit.

4. To work through binary technologies, possessing of the unique viability in the North conditions, in order to their perspective implementation at the Mutnovsky Geothermal Power plant and the wide spreading in Russia and abroad.

Relatively low cost of the 4<sup>th</sup> power unit of the Verchne-Mutnovsky Geothermal Power plant and an opportunity of its construction in such short space of time as 22-28 months are provided with the following factors:

1. The 4<sup>th</sup> power unit completion is possible using domestically stock-produced equipment (up to 85%);
2. The main equipment (turbo-generators) is planned to be delivered at 100% factory readiness, being fully preliminarily tested under load at the factory;
3. Possibility of conducting accelerated construction-and-assembling operations within short summer periods (3-4 months) at the expense of today's well-developed Verchne-Mutnovsky Geothermal Power plant infrastructure available, and the experience of geothermal power plant building in these climatic conditions.
4. Deficiency of expensive sophisticated and long-term drilling and well constructing works.

Technological scheme of the 4<sup>th</sup> power unit of the Verchne-Mutnovsky Geothermal Power plant constitutes an aggregate of the 1<sup>st</sup> and 2<sup>nd</sup> circuit inseparably linked with each other.

The 1<sup>st</sup> circuit of the 4<sup>th</sup> power unit operates using geothermal fluid. Two-phase mixture from 049 well enters the separator and falls into steam (the Russian up-to-date separators enable to achieve steam with  $x=0.9995$ ) and brine. The steam operates in the turbine and moves to the condenser-evaporator. There in the beginning the steam is condensed, and then the steam condensate cools and directs into the re-injection well. Thus, the 1<sup>st</sup> circuit is environmentally friendly.

In the 4<sup>th</sup> circuit of the power unit of 2.5-MW<sub>e</sub> capacity, a low-boiling working fluid is used. Since the 2<sup>nd</sup> circuit is closed and leak-free, therefore it is environmentally friendly, as the whole 4<sup>th</sup> power unit. The 2<sup>nd</sup> circuit working body after the feed-pump comes into the condenser-evaporator, where it is firstly preheated and evaporated at the expense of the worked out steam heat after the 1<sup>st</sup> circuit turbine, and enters the super-heater. There the fluid is overheated owing to the brine heat and enters the 2<sup>nd</sup> circuit turbine. After the steam expanding in the turbine the worked out steam comes to the air-condensing installation, condenses, and enters the feed-pump inlet.

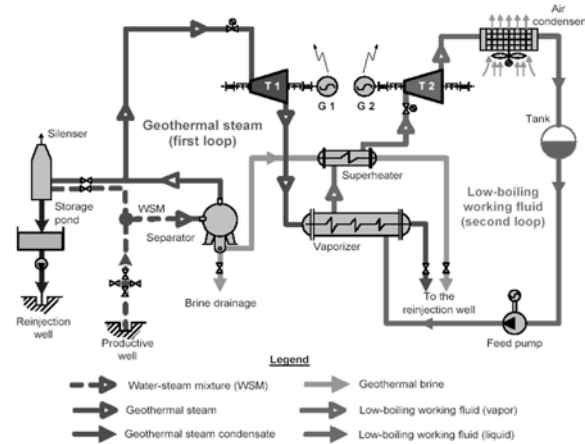

Figure 5. Heat scheme of 4<sup>th</sup> power unit.

The detailed heat scheme is presented at the Figure 5.

The layout and main elements of the 4<sup>th</sup> power unit are designed taken into account the climatic conditions of Kamchatka: strong snowdrifts, minus 30°C temperature in winter, and at last, the permanent wind, which speed varies from 5 to 40m/sec.

## 5.0 PERSPECTIVES OF THE GEOTHERMAL POWER COMPLEX DEVELOPMENT IN KAMCHATKA

Geothermal heat resources explored allow increasing considerably the total installed capacity of the power complex at the Mutnovsky reservoir during the nearest years (Povarov et al., 2001).

Now the Business-plan for the construction of the 2<sup>nd</sup> stage of the Mutnovsky Geothermal Power Plant of 100-MW<sub>e</sub> capacity is made using EBRD Grant and Geotherm SC funds. It is supposed to commission the object in 2007-2008.

The Mutnovsky reservoir geothermal fluid includes up to 50% of 180°C liquid phase, having sufficiently high potential, and can be effectively used in the power binary technologies. The program of the creation of series of geothermal power units, working on exhaust geothermal fluid (hot water) from the Verchne-Mutnovsky Geothermal Power plant and the 1<sup>st</sup> stage of the Mutnovsky Geothermal Power plant, is under active implementation by Geotherm SC and Nauka SC.

In 2004 it is planned to put into operation the 4<sup>th</sup> combined binary power unit of the Verchne-Mutnovsky Geothermal Power plant of 6.5-MW<sub>e</sub>. At the same time Geotherm SC keep working under the creation of four binary geothermal power units (of 4.0-MW<sub>e</sub> capacity each) to utilize the exhaust geothermal fluid of the 1<sup>st</sup> stage of the Mutnovsky Geothermal Power plant.

In all it is intended to bring the total installed capacity of the geothermal power complex at the Mutnovsky reservoir to 300-MW<sub>e</sub>.

## REFERENCES

- Britvin, O.V., Povarov, O.A., Klochkov, E.F., Tomarov, G.V., and Luzin, V.E. (2000). Mutnovsky geothermal power complex in Kamchatka. *Proceedings World Geothermal Congress 2000: pp. 3139-3144.*
- Britvin, O.V., Povarov, O.A., et al. (2001). The Mutnovsky geothermal power complex in Kamchatka. *Thermal Engineering, Vol.48, No.2, pp. 89-95.*
- Kiryukhin, A.V. (1996). Modelling studies: The Dachny geothermal reservoir, Kamchatka, Russia. *Geothermics, Vol.25, No.1, pp.63-90*
- Povarov, O.A., Nikolski, A.I., and Postnikov, A.I. (2001). Power plants at the Mutnovsky geothermal field (Kamchatka). *Transactions of the Geothermal Resources Council. Vol. 25, pp. 543-548.*