

RESERVOIR RESPONSE TO OPTIMISED REINJECTION SCHEME OF TONGONAN-1 PRODUCTION FIELD, LEYTE, PHILIPPINES

Farrell L. Siega, Roel S. Ahcastre, and Egmedio V. Parrilla Jr.

PNOC-Energy Development Corporation, Makati, Philippines

Abstract

Reinjection of the separated geothermal brine from Tongonan-1 production field to Mahiao and Sambaloran reinjection wells started as early as 1984. Changes in chemical and physical characteristics of most of the production wells in Lower Mahiao and Sanibalaran sectors indicate a major reinjection fluid breakthrough in these sectors. The reinjection fluid is believed to be dispersed through Mahiao East, Urangon and Sanibalaran faults.

Optimized utilization of reinjection wells 2R3D and 2R4D in Sanibalaran sector after successful acidizing of 2R4D in 1991 resulted to significant recovery of Sanibalaran production field from reinjection fluid breakthrough. Continued chemical and physical recovery of Sambaloran wells from reinjection fluid due to reduction of wastewater load at wells 2R3D and 2R4D induced pressure drawdown in this sector. This is manifested by the continuous increase in discharge enthalpy, concentration of CO₂ in the total discharge and reservoir chloride. The effects of drawdown are most notable in wells 212 and 213 in Sanibalaran sector.

1.0 INTRODUCTION

The Tongonan-1 production field (TIPF) consisting of Mahiao and Sambaloran sectors is situated in the central part of the Tongonan geothermal field (Fig. 1). Fifteen (15) production wells from both sectors are utilised to provide the steam requirements of the 112.5MWe Tongonan-1 power plant of the National Power Corporation (NPC) which has been in commercial operation since 1983.

The separated geothermal brine from the Mahiao and Sambaloran production sectors were disposed through hot injection since 1983 to wells 1R3 and 1R5D in Mahiao and 2R3D and 2R4D in Sambaloran, respectively. Wells 1R8D and 1R4DA were commissioned in 1990 and 1991, respectively to accommodate the increasing reinjection load due to high power demand. Several production wells adjacent to the Tongonan-1 reinjection sink (e.g. 101, 105D, 214 and 215) indicated reinjection fluid breakthrough in 1990. Based on the chemical changes in the well, the estimated reinjection fluid breakthrough in 1995 ranges from 30 to 58% in wells 101, 103, 105D, 209A, 213, 214 and 215 (Solaña and Macambac, 1996).

The results of tracer tests and structural studies conducted in the area indicated that flow of injected fluids towards the Mahiao and Sambaloran production sectors are dispersed through the Mahiao East, Sambaloran and Urangon faults (Alincastre, 1992). Permeability of reinjection wells 1R3, 1R4DA, 1R5D and 1R8D are also attributed to the interception of Urangon, Sambaloran and Mahiao East fault, a segment of the north-trending Mahiao graben. Wells 2R3D and 2R4D also intercepted the Urangon and Sambaloran faults.

Reinjection fluid breakthrough in well 212 was observed in 1995. The increasing mineralization in this production well situated farthest from the reinjection sink indicates that reinjection fluid dispersion in Sambaloran could already be extensive. To arrest further inflow of reinjection fluids, reinjection load at wells 2R3D and 2R4D were reduced with the excess waste brine diverted to Mahiao reinjection system through a redundant line.

This paper aims to present the response of the reservoir from optimized reinjection scheme based on the chemistry of the production wells. Fluid chemistry of the Tongonan-1 production wells were monitored and were primarily considered in the evaluation of the reservoir characteristics.

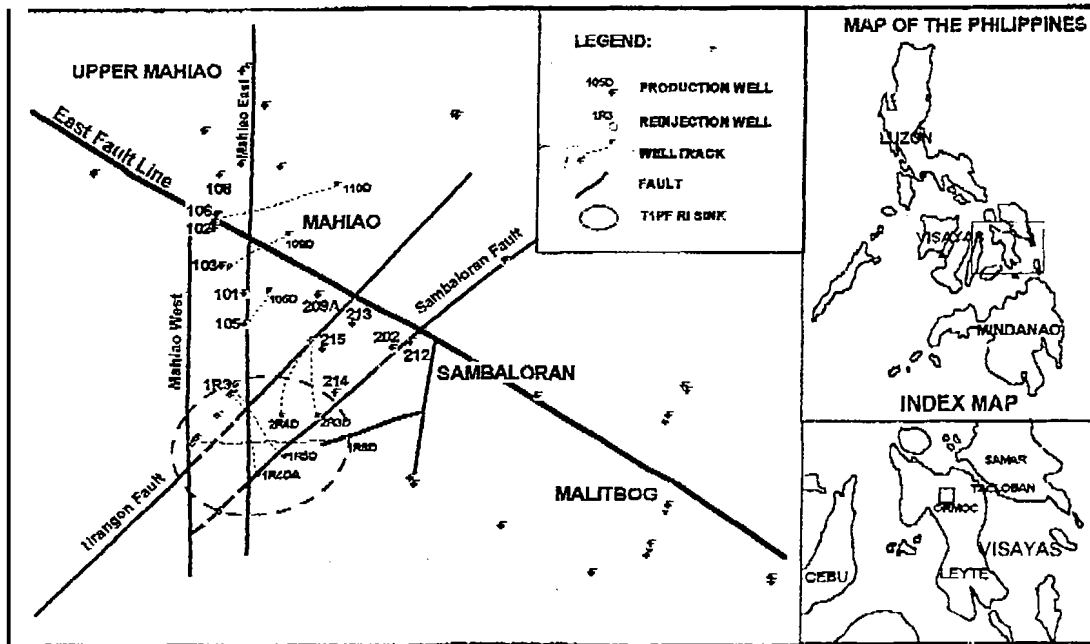

Figure 1. Location Map of Tongonan-1 production Field showing production, reinjection wells and major structures

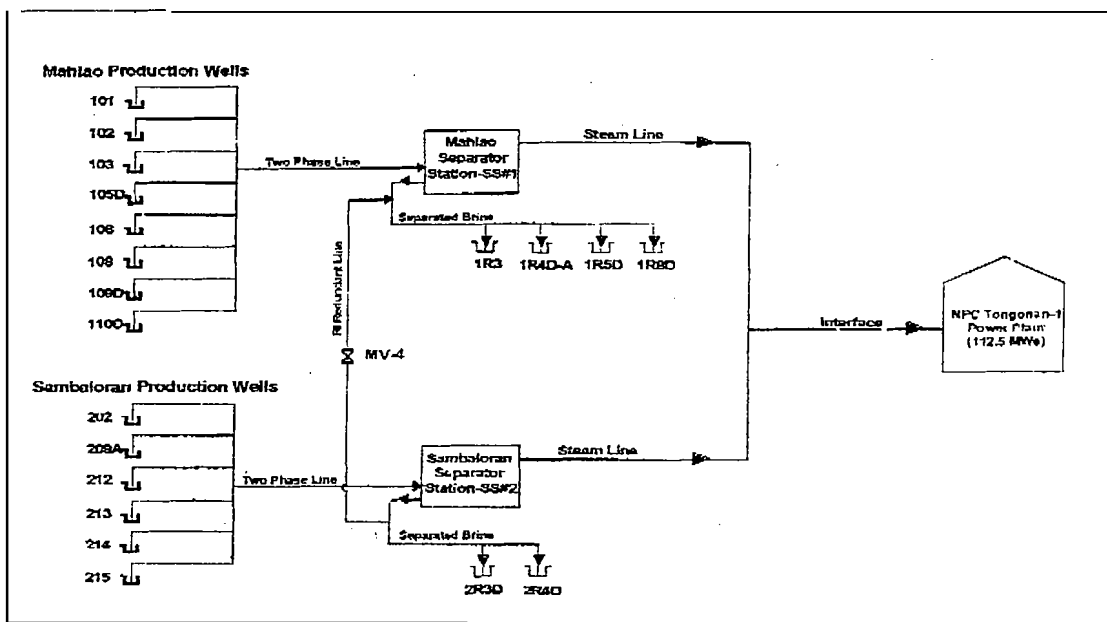

Figure 2. Schematic flow diagram of Tongonan-1 Production Field Fluid Collection and Disposal System (FCDS).

20 REINJECTION HISTORY

The injection of separated brine has been continuously implemented in Tongonan-1 production field since 1983 to attain zero disposal to the environment. The separated brine from Mahiao production wells at Separator Station #1 (SS1) is being disposed to reinjection wells 1R3, 1R4DA, 1R5D and 1R8D. In Sambaloran, the waste water from Separator Station #2 (SS2) is being injected to wells 2R3D and 2R4D. Figure 2 shows the process flow diagram of the TIPF Fluid Collection and Disposal System (FCDS).

Figure 3 shows the reinjection well utilization of Tongonan-1 production field. Initially, three reinjection wells, 1R5D, 2R3D and 2R4D in Mahiao and Sambaloran sectors were utilized to accept the separated brine load. Well 1R3 was put on-line in 1984 to augment the increasing reinjection load at Maluao sector. Due to increasing wellhead pressure, which causes the injected fluid to back flow, well 2R3D was cut-out in service in 1988. The declining injection capacity of well 2R4D and cut-out of well 2R3D has reduced the reinjection load at Sambaloran sector. The excess brine (-90 kg/s) then from this sector was diverted to Mahiao reinjection system through a redundant line.

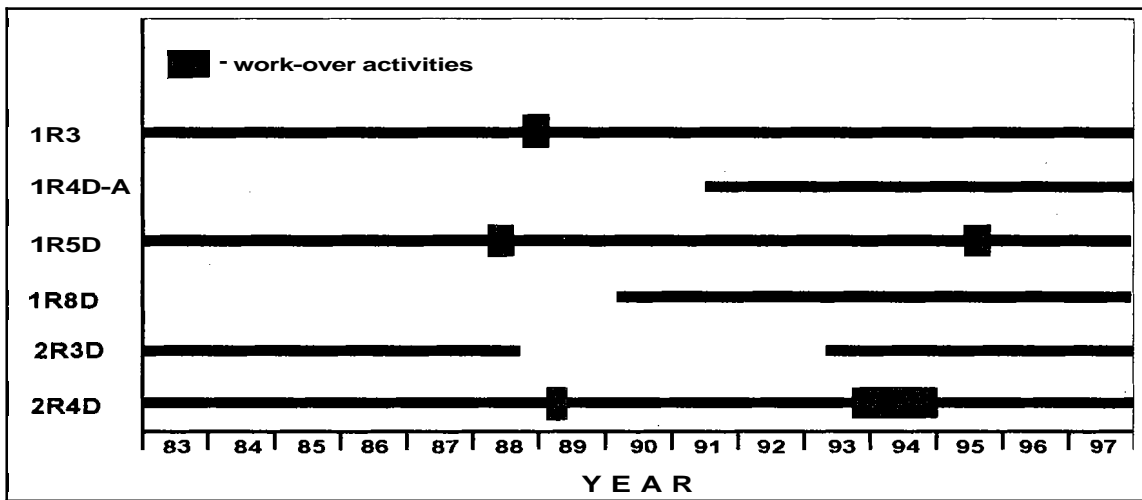

Figure 3. Reinjection wells utilization of Tongonan-1 Production Field.

The continued decline of reinjection well capacities of wells 1R3, 1R5D and 2R4D due to silica deposition and the corresponding increase of reinjection requirements prompted the drilling and utilization of wells 1R8D and 1R4D-A in 1990 and 1991, respectively. Subsequently, the reinjection load in Mahiao sector increased from the monthly average of about 120,000 tons in 1989 to 286,054 tons in 1990. Similarly, with the low enthalpy well utilization in Sambaloran sectors, the total mass injected increased from an average of 250,000 tons in 1989 to 320,000 tons in 1993. Well 2R3D was re-commissioned in 1993 after modification in the branchline configuration was completed to augment the increasing reinjection load and the declining capacity of well 2R4D in Sambaloran (Fig. 4).

Mechanical work-over was conducted in wells 1R3 and 1R5D in 1988, and in well 2R4D in 1990 to drill-out mineral deposits in the well bore. Due to continued decline in the capacity of wells 2R4D and 1R5D, work-over operation with subsequent acidising was successfully conducted in these wells between 1993 and 1995 to further flush out scales in the well bore and in the formation. After work-over and acidising, the injection capacity of wells 2R4D and 1R5D significantly increased to 198 and 90 kg/s from its pre-acidised capacity of 20 and 40 kg/s, respectively.

At present six (6) reinjection wells with a total capacity of 530 kg/s are being utilized to accommodate the required reinjection load of -250 kg/s for both sectors. The current low reinjection requirement at Tongonan-1 production field is attributed to the lower power load of the Tongonan-1 power plants due to turbine PMS and topping cycle activities at Mahiao sector.

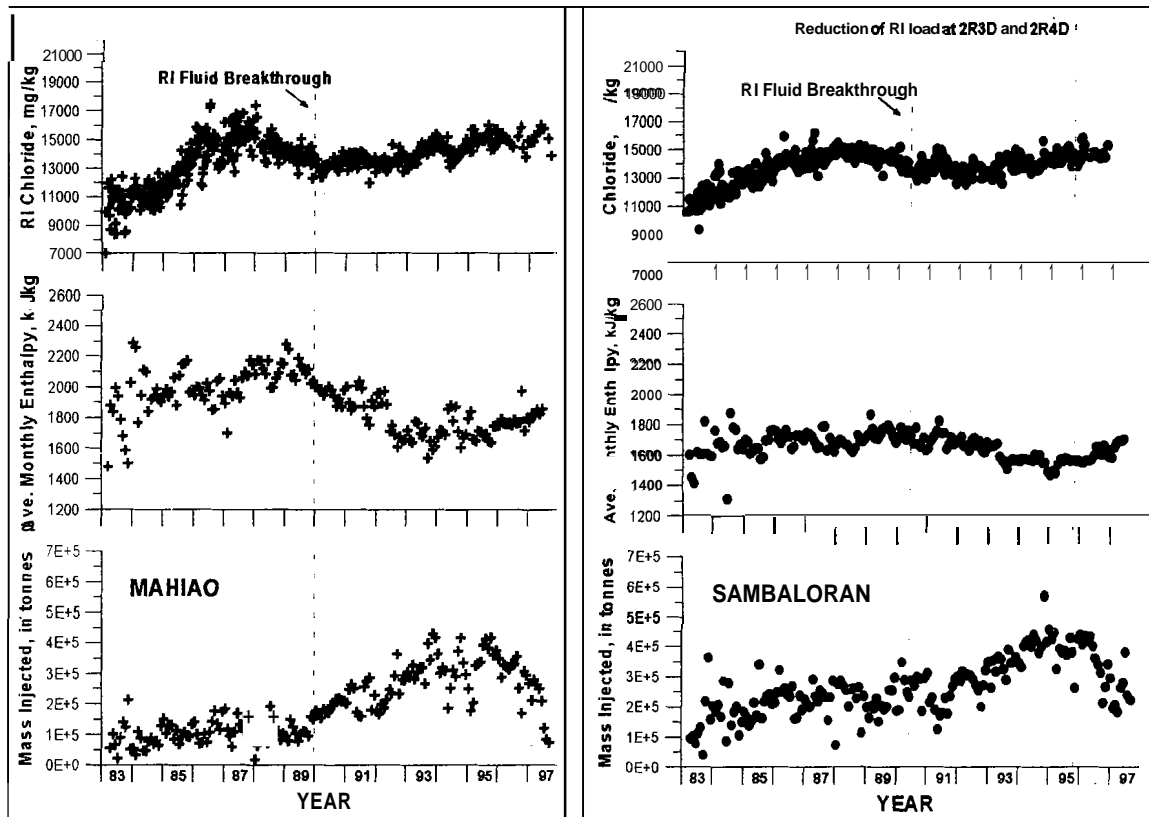

Figure 4. Plots of reinjection line chloride and average monthly field enthalpy with time for Mahiao and Sambaloran

3.0 REINJECTION FLUID BREAKTHROUGH

Variation of chemical parameters in some of the production wells in Mahao and Sambaloran production sectors are attributed to reinjection fluid breakthrough. Production wells adjacent to the Tongonan-1 production field reinjection sink were affected by reinjection fluid returns since 1989. Entry of highly saline ($>11,000$ mg/kg) and colder ($<180^{\circ}\text{C}$) reinjected fluid from the southwest is illustrated in Figure 5. Chloride enrichment from the southwest is primarily attributed to reinjection fluid breakthrough.

Moreover, plots of Cl_{id} and discharge enthalpy of T1PF wells in Figure 5. show the significant shift of most of the production wells towards the reinjection **mixing** line from their pre-exploitation state (Salonga, et al, 1996). Reinjection fluid breakthrough are manifested in wells 101, 103, 105D in Mahiao and wells 202, 212, 213, 214 and 215 in Sambaloran sector. Reinjection fluid enrichment of about 40 - 60% were observed in wells 101, 105D, 214 and 215 which are located at the periphery of the reinjection sink. Output of these wells significantly decline as a result of reinjection fluid breakthrough (Solafía and Macambac, 1995).

The mass of reinjected waters migrating towards the production wells of Mahiao and Sambaloran sectors is illustrated in the $\text{iso-}\delta^{18}\text{O}$ contour map in Figure 6. The apparent identification of contours representing isotopically enriched fluid from the southwest corresponds to the migrating fluids from the reinjection sink towards the production sector. $\text{Iso-}\delta^{18}\text{O}$ and Cl_{res} cross plots characterize the shift of most of the T1PF wells above the baseline regression line as a result of reinjection fluid **mixing** (Salonga and Siega, 1996). Similarly, peripheral wells 102 and 106 showed entry of reinjection fluid of about 27 to 29% at prolonged throttled discharge in late 1992 (Salonga, et al. 1996).

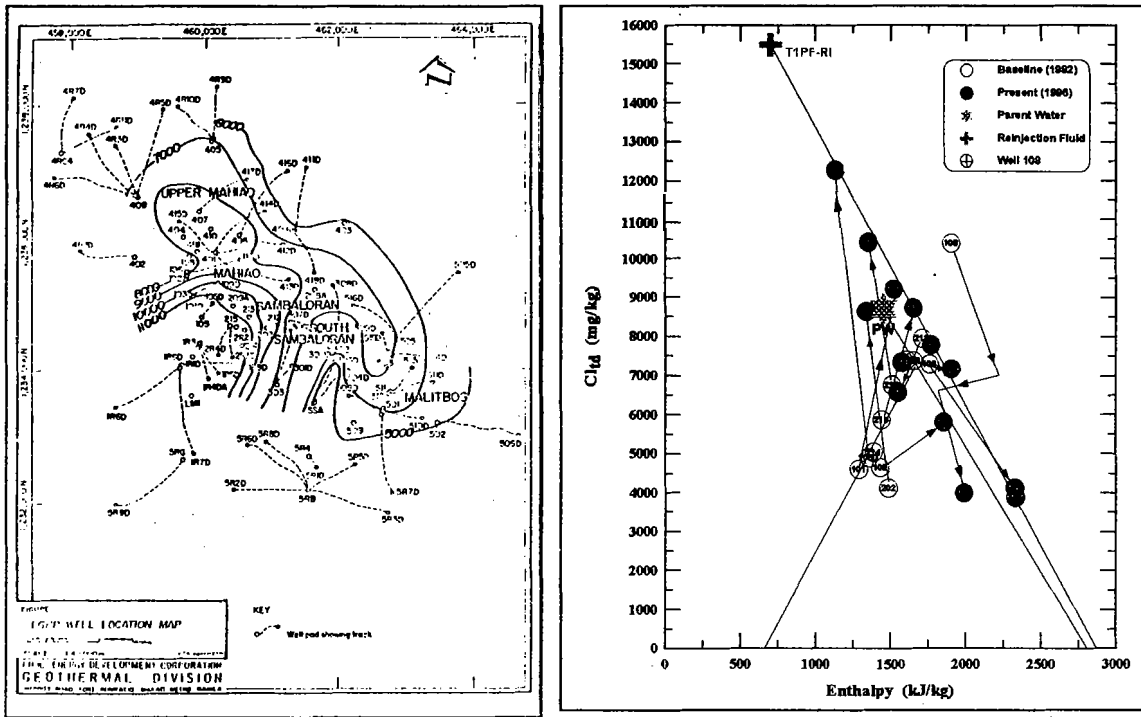

Figure 5. Iso- Cl_{res} contour map across Tongonan geothermal field and cross plot of Cl_{res} and discharge enthalpy of T1PF wells.

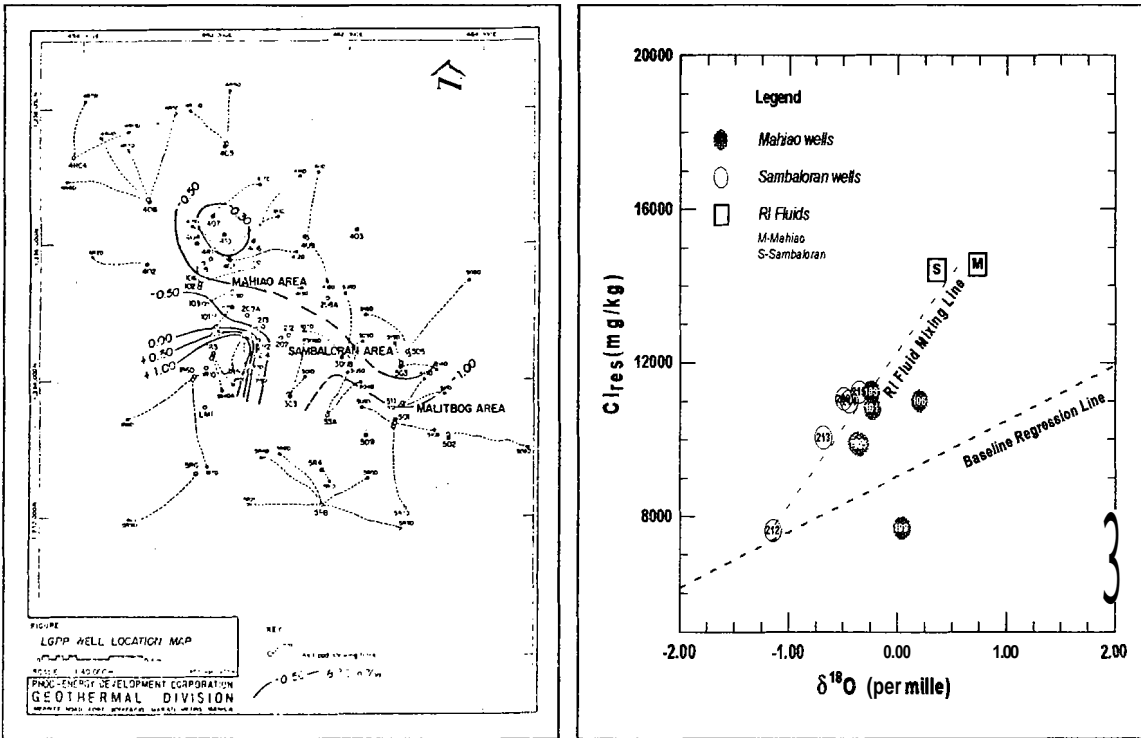

Figure 6. Iso- $\delta^{18}O$ contour map across Tongonan geothermal field and cross plot of $\delta^{18}O$ and Cl_{res} of T1PF wells.

4.0 OPTIMISED REINJECTION SCHEME

The increase of reinjection load during the cut-in of well 2R3D and 2R4D in 1993 and 1994, respectively resulted to reinjection fluid breakthrough in Sambaloran production sector. The influx of colder (<180°C) and highly saline reinjection fluid observed in well 212 indicates the extent of the reinjection fluid breakthrough in Sambaloran sector. The continued increasing mineralization with significant thermal decline in wells 212, 213, 214 and 215 is most likely the result of utilization of well 2R4D after acidising. Hence, reinjection strategy in Tongonan-1 production field specifically in wells 2R3D and 2R4D was revised on September 1995.

Reinjection load in wells 2R3D and 2R4D was reduced from 140 to an average of 90 kg/s with the excess waste brine diverted back to Mahiao reinjection system through the redundant line MV-4. Both wells 2R3D and 2R4D were utilized at an average injection rate of 45 kgl, way below their injection capacity of 98 and 1% kgl, respectively. This optimized reinjection scheme was implemented on September 1995.

5.0 RESPONSE OF PRODUCTION WELLS TO OPTIMISED REINJECTION SCHEME

The reduction of load in wells 2R3D and 2R4D as an optimised reinjection scheme in Tongonan-1 production field resulted to significant recovery from reinjection fluid breakthrough in some of the Sambaloran production wells. The initial response of the reservoir was observed as early as October 1995 in wells 212 and 213. The previously increasing Cl_{res} in well 212 and 213 appeared to have stabilized at -8,500 mg/kg and 9,700 mg/kg, respectively, from October 1995 to March 1996 (Fig. 7).

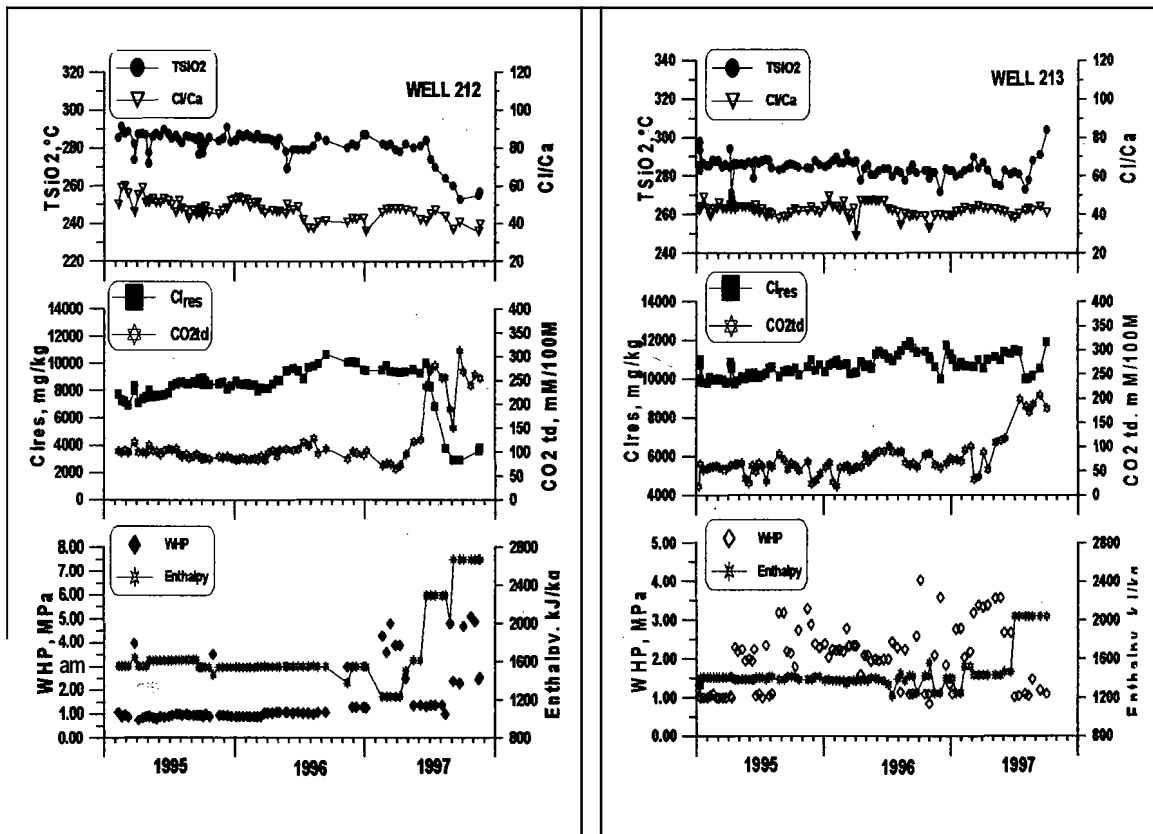

Figure 7. Cl_{res} , CO_{2td} , $T(SiO_2)$ and field enthalpy trends of wells 212 and 213 from 1995 to 1997 indicating the recovery from RI fluid returns and subsequent field-wide drawdown.

The continued limited reinjection fluid dispersal and subsequent production at Sambaloran sector likely induced field-wide boiling in the reservoir. This condition is manifested by the increasing trend of Cl_{res} , CO_{2d} and discharge enthalpy in wells 212 and 213 in the ~~third~~ quarter of 1996. Towards the end of 1996, most of the production wells in T1PF have indicated significant increase in enthalpy and steamflow, and decline in waterflow. The production well chemistry monitoring as of November 1997 showed several wells in Maluao and Sambaloran sectors discharging less mineralized, lower temperature and gassy fluids. This trend is most evident in wells 212 and 213 wherein significant decline in $T(SiO_2)$ and Cl_{res} , and increase in CO_{2d} could be observed. The increasing trend in $T(SiO_2)$ and Cl_{res} at the end of November in well 213 suggests possible migration of hotter fluids coming from the vicinity of well 209A.

Based on gas equilibria (D'Amore et. al., 1995), the Sambaloran sector is severely affected by RI fluid returns in 1995 as shown by the trends of wells 212 and 213 which have steam fraction of between -0.001 to -0.01 (Fig. 8). Coinciding with the change in reinjection strategy in 1995, these wells indicate increase in steam fraction from the previous range to almost zero in 1996 suggesting the recovery from RI fluid returns. For 1997, significant gain in steam fraction of as much as 0.01 is observed in these wells suggesting sufficient boiling and steam addition in the reservoir. Steam availability in Sambaloran production sector increased from 547 TPH in March 1996 to as much as 589 TPH in November 1997. All of the observed chemical changes could be attributed to field-wide pressure drawdown experienced in the later part of 1996, which possibly resulted to steam addition, and caused the expansion of the two-phase zone across the Tongonan-1 production field

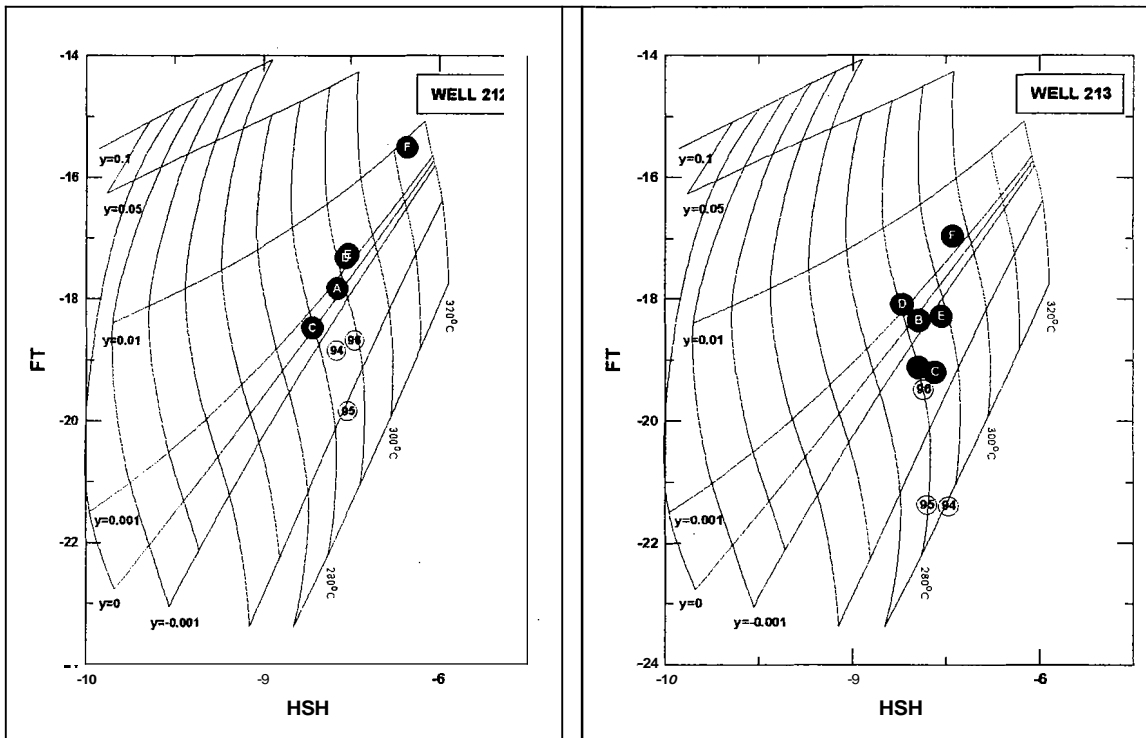

Figure 8. FT-HSH cross plot of Sambaloran wells showing gain in steam fraction due to boiling and steam addition in the reservoir (1997 datapoints represented by letter and closed circle).

Figures 9 and 10 illustrate the Cl_{d} and CO_{2d} correlation with enthalpy for Mahiao and Sambaloran production wells as of November 1997. The reinjected fluids from Maluao and Sambaloran sectors have elevated Cl level of 13,000-15,000 mg/kg and zero CO_{2d} composition. Well 105D in Mahiao sector plotted near the RI fluid composition suggesting that it is still affected by RI returns. The rest of the Mahiao wells indicate declining trend in Cl_{d} and increasing trend in CO_{2d} and enthalpy possibly correlated to **steam** addition due to pressure drawdown.

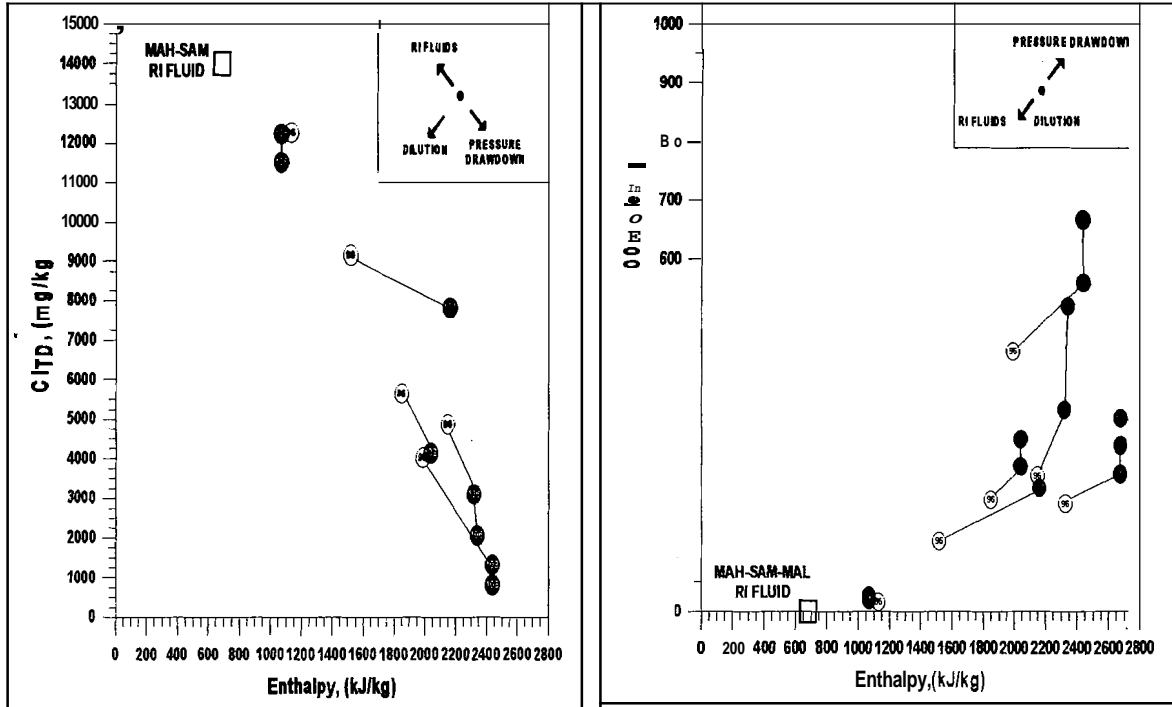

Figure 9. Correlation of Cl_{td} and CO_{2td} with field enthalpy for the Mahiao wells indicating trends related to pressure drawdown and RI returns. The cross plot shows wells 105D still affected by RI returns while the rest of Mahiao wells indicate steam addition due to drawdown.

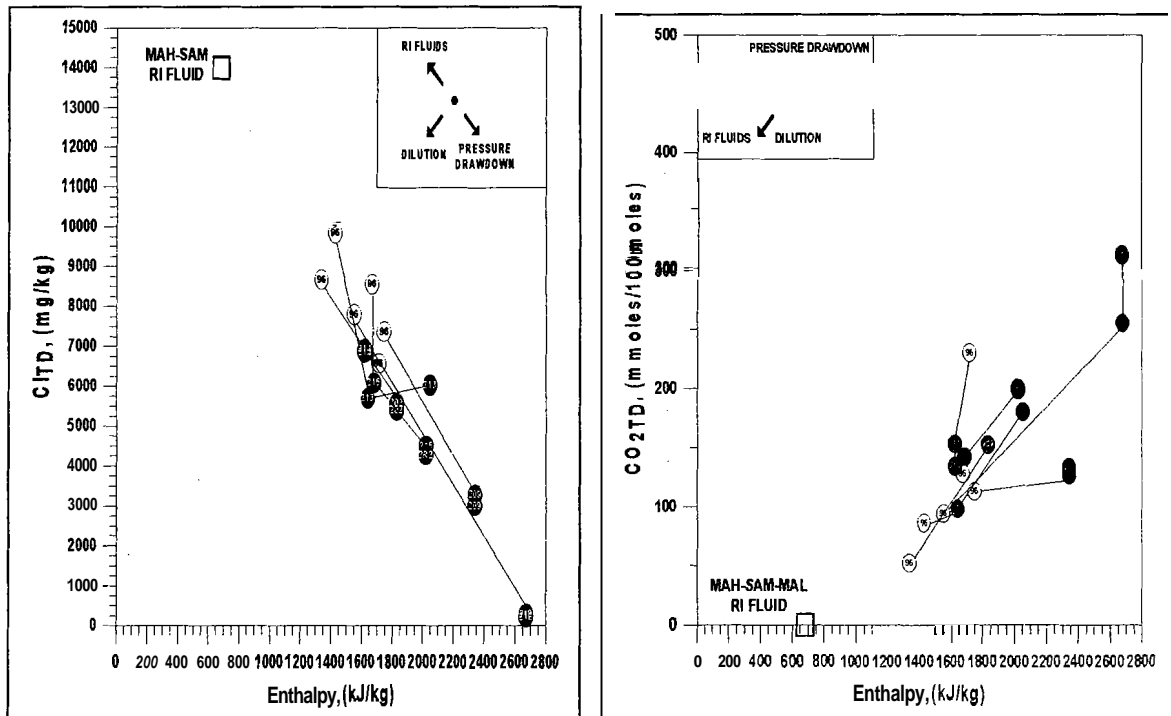

Figure 10. Correlation of Cl_{td} and CO_{2td} with field enthalpy for the Sambaloran wells indicating trends related to pressure drawdown and RI returns. Except for well 214, all of the wells show declining trend in Cl_{td} and significant increase in enthalpy.

In Sambaloran sector, except for well 214, all of the wells have **increasing** trend in enthalpy and CO_{2fd} , and **declining** trend in Cl_{fd} . The most affected wells is well 212 which showed the highest increase in enthalpy. There is also **significant** decline in the waterflow and corresponding increase in the steamflow of this well. As for well 214, present fluid **chemistry** showed that it is still affected by RI returns possibly due to its proximity to wells 2R3D and 2R4D, and there is **no** indication that this well is affected by pressure drawdown.

6.0 SUMMARY

The extensive dispersion of reinjection fluid in Sambaloran sector as observed in wells 212 and 213, prompted the reduction of reinjection load at wells 2R3D and 2R4D to an average of 90 kg/s total injection rate way below their injection capacity of 98 and 196 kg/s, respectively. The optimised reinjection scheme resulted to **significant** recovery from RI fluid returns of the Sambaloran sector, which could be observed in wells 212 and 213.

Initially, the observed declining mineralization with corresponding increase in CO_{2fd} and discharge enthalpy of wells 212 and 213 is associated with the recovery from reinjection fluid breakthrough. However, the continued reduced reinjection in wells 2R3D and 2R4D, and production from this sector induced field-wide pressure drawdown. As a result, the extensive boiling experienced during this period may have caused steam addition and expansion of the two-phase zone across the Tongonan-1 production field. This process is evident in Mahiao and Sambaloran wells which have indicated significant increase in enthalpy and steamflow, and decline in waterflow.

Currently, to avert further advancement of the reservoir-wide pressure drawdown in TIPF, reinjection load at wells 2R3D and 2R4D were increased by ~40 kg/s. The utilization of wells with high waterflow in Mahiao and Sambaloran sectors was likewise being implemented.

REFERENCES

- Alincastre, R.S., 1992. Structural Interpretation of the Reinjection Fluid Movements in the Tongonan-1 Production Field, Leyte, Philippines. PNOC-EDC Internal Report.
- Alincastre, R.S., Siega, F.L, and Villa, R.R., 1997. Leyte Geothermal Power Project Geochemistry Technical Report (January - March 1997). PNOC-EDC Internal Report.
- Salonga, N.D., Auman, R.O and Alincastre, R.S., 1996. What Have Happened to Wells 102, 106 and 108 from 1983 to 1996? PNOC-EDC Internal Report.
- Salonga, N.D, Alincastre, R.S. and Auman, R.O., 1996. The Geochemical Model of Tongonan Geothermal Field Prior to Full Commissioning of 450 MWe Power Plants. In Proc. 17th Annual PNOC-EDC Geothermal Conference, Manila, Philippines.
- Salonga, N.D. and Siega, F.L., 1996. The Stable Isotope Changes in Tongonan-1 production Field as a Response to Exploitation from 1983 to 1995. PNOC-EDC Internal Report.
- Seastres, J.S, Jr., Salonga, N.D., Saw, V.S. and Clothworthy, A.W., 1996. Pre-commissioning Hydrology of the Greater Tongonan Geothermal System, Philippines and its Implications to Field Exploitation. PNOC-EDC Internal Report.
- Siega, F.L. and Salonga, N.D., 1996. Stable Isotope Systematics in Tongonan-1 Production Field, Leyte, after 12 Years of Commercial Operations. In Proc. 17th Annual PNOC-EDC Geothermal Conference, Manila, Philippines.
- Solafia, R.R and Macambac, R.V., 1995. "1995 Geochemistry Technical Report". PNOC-EDC Internal Report.